

Parts List			
ITEM	QTY	PART NUMBER	DESCRIPTION
1	1	LST1100D	100 PSI DECAL (N/S)
2	1	LST5100	1/2" LST SCREEN - 100 MESH
3	1	LSTM050BC	MINI T-STRAINER CLEAR BOWL
4	1	LSTM050G	MINI T-STRAINER GASKET
5	1	LSTM050H	1/2" NPT MINI T-STRAINER HEAD

NOTE:
ADDITIONAL CLEARANCE REQ'D
FOR SCREEN REMOVAL: 2 3/4"

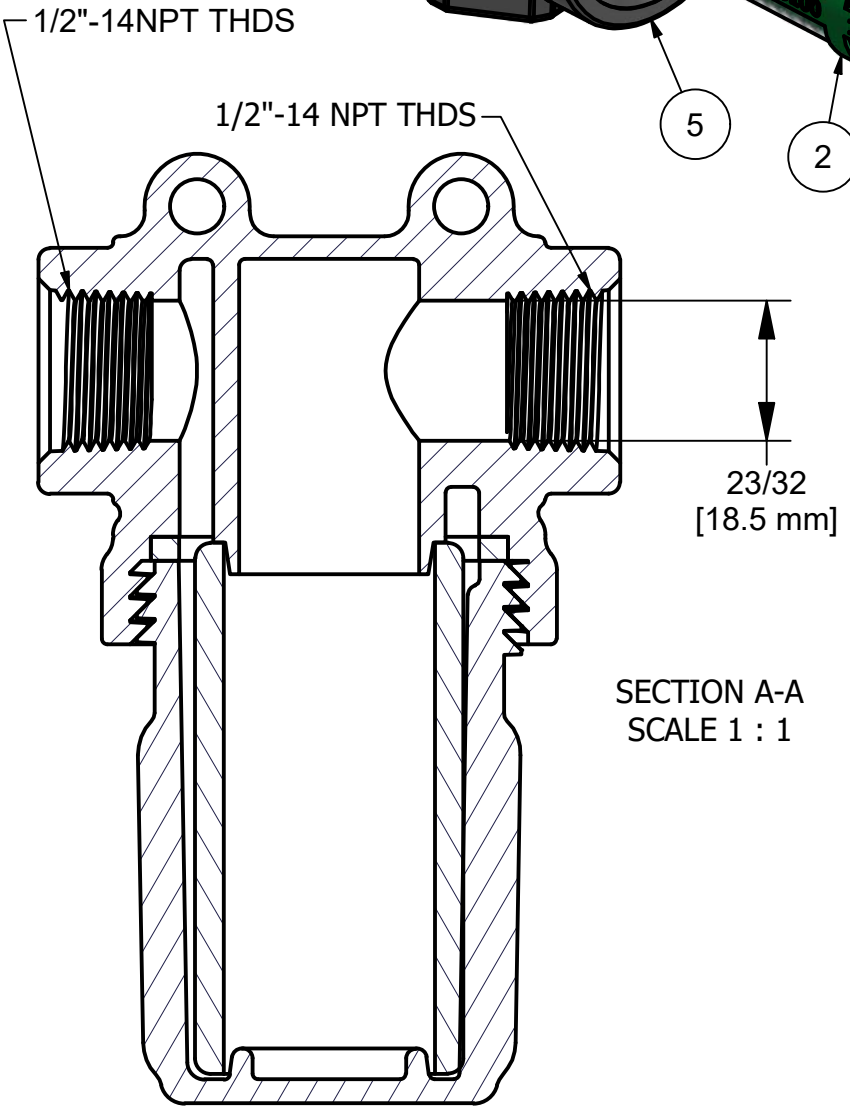
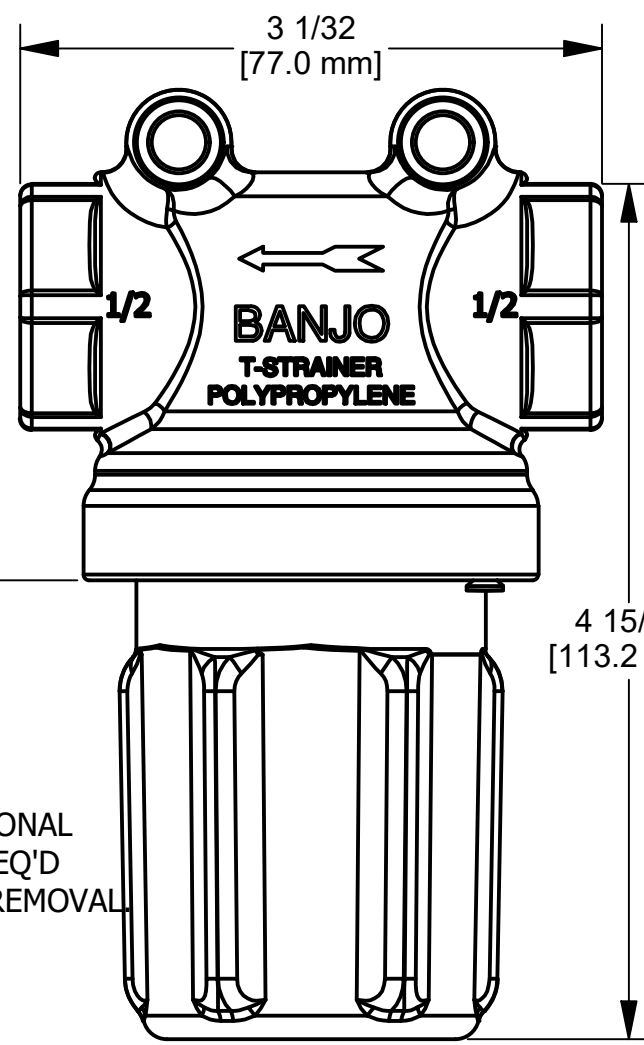
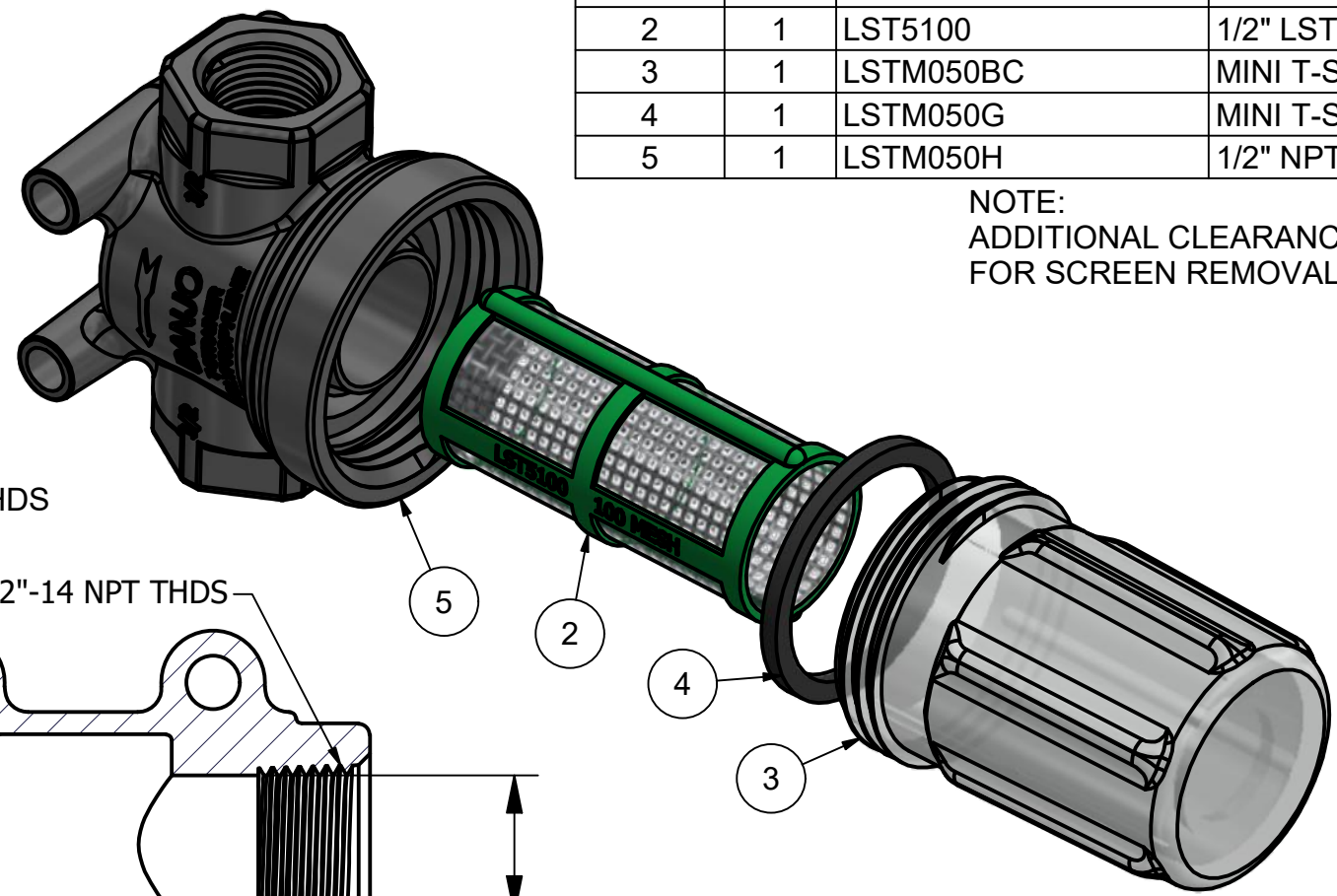

SECTION A-A
SCALE 1 : 1

2 3/4" ADDITIONAL
CLEARANCE REQ'D
FOR SCREEN REMOVAL

THIS DRAWING AND ALL
INFORMATION CONTAINED THEREON
ARE THE EXCLUSIVE PROPERTY OF
BANJO CORPORATION.

UNLESS SPECIFICALLY NOTED, THIS
DRAWING AND ITEMS SHOWN ON
THIS DRAWING ARE SUBJECT TO
CHANGE AT ANY TIME.



BANJO CORPORATION

150 BANJO DRIVE, CRAWFORDSVILLE, IN 47933
WEB SITE: WWW.BANJOCORP.COM
E-MAIL: BANJOSALES@IDEXCORP.COM

DESCRIPTION	1/2" T-Strainer w/ Clear Bowl - 100 Mesh
PART NUMBER	LSTM050-100C

4

3

4

2

1