

PARTS LIST			
ITEM	QTY	PART NUMBER	DESCRIPTION
1	1	LST530	1/2" LST SCREEN - 30 MESH
2	1	LSTM050B	MINI T-STRAINER BOWL
3	1	LSTM050G	MINI T-STRAINER GASKET
4	1	LSTM050H	1/2" NPT MINI T-STRAINER HEAD

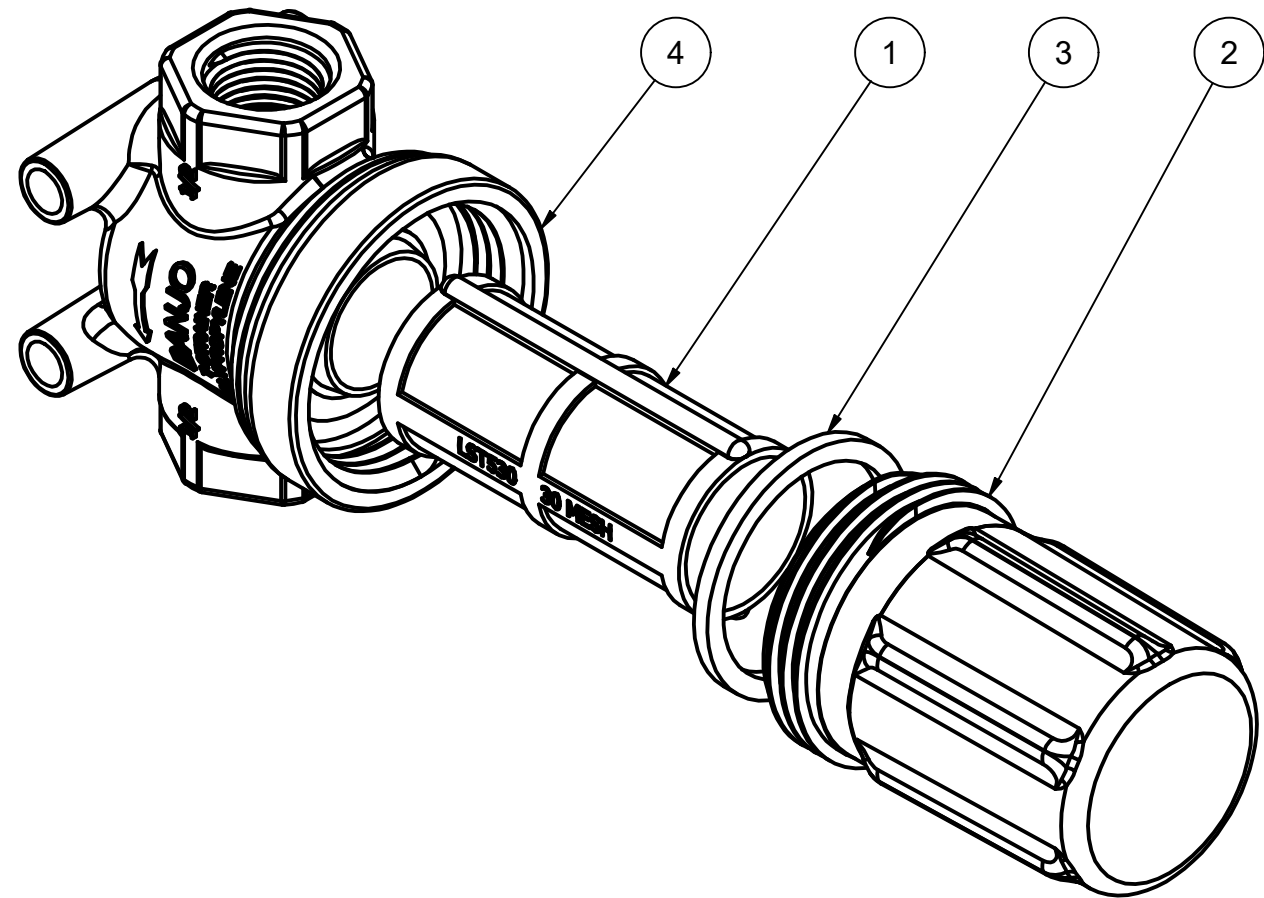
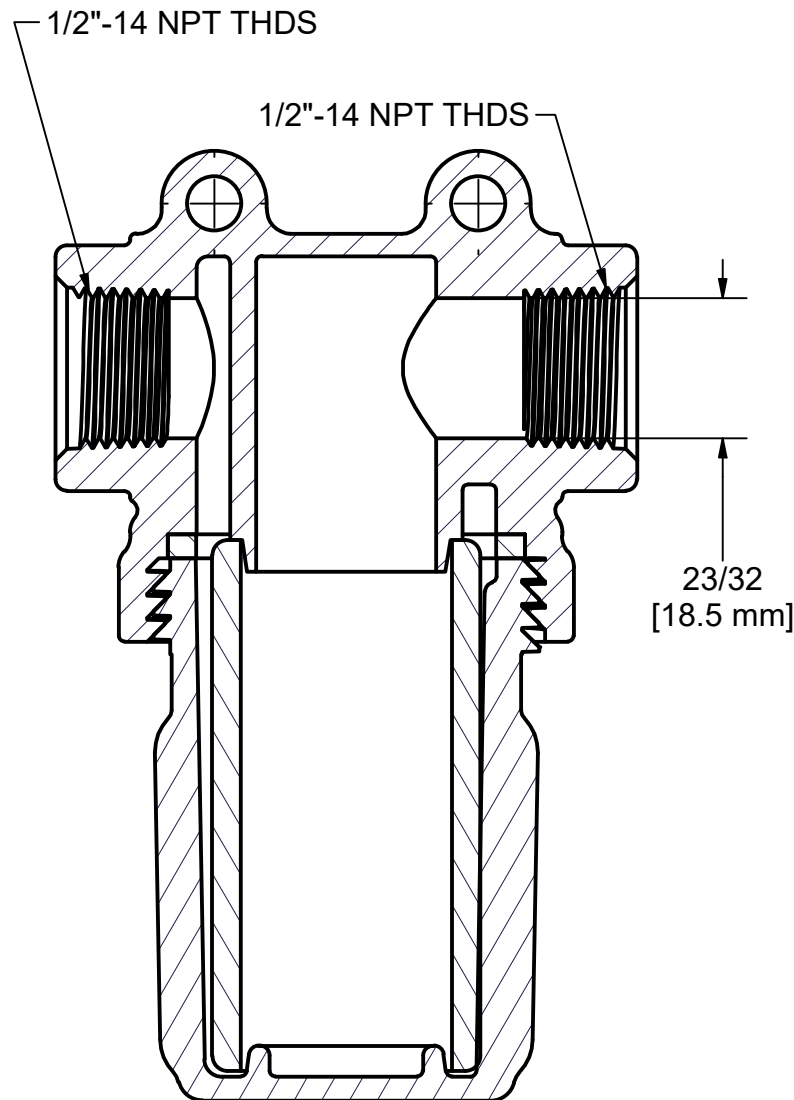
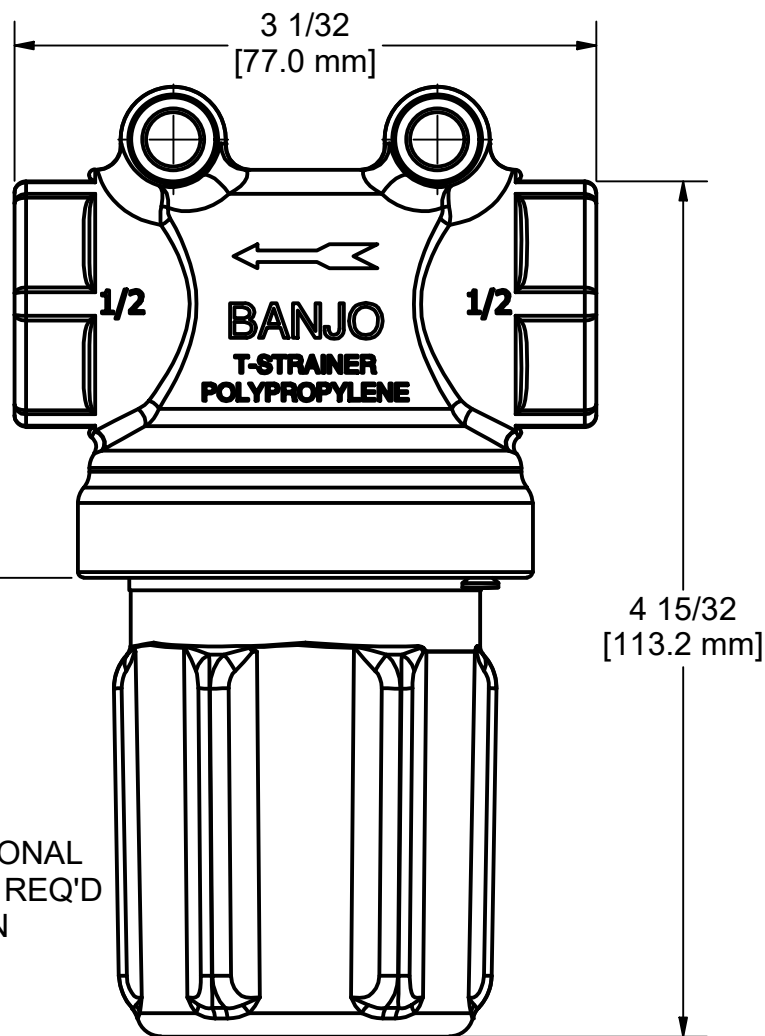
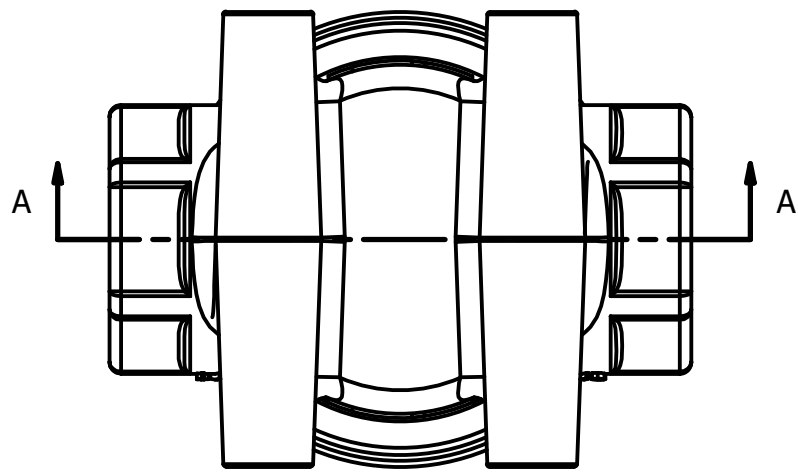

SECTION A-A
SCALE 1 : 1

THIS DRAWING AND ALL INFORMATION CONTAINED THEREON ARE THE EXCLUSIVE PROPERTY OF BANJO CORPORATION.

UNLESS SPECIFICALLY NOTED, THIS DRAWING AND ITEMS SHOWN ON THIS DRAWING ARE SUBJECT TO CHANGE AT ANY TIME.



BANJO CORPORATION
A UNIT OF IDEX CORPORATION
150 BANJO DRIVE, CRAWFORDSVILLE, IN 47933
WEB SITE: WWW.BANJOCORP.COM
E-MAIL: BANJOSALES@IDEXCORP.COM

DESCRIPTION:	1/2" T-STRAINER - 30 MESH
PART NUMBER:	LSTM050-30

2 3/4" ADDITIONAL CLEARANCE REQ'D FOR SCREEN REMOVAL.