

PARTS LIST			
ITEM	QTY	PART NUMBER	DESCRIPTION
1	1	CE050D	1/2" CE LABEL (N/S)
2	1	LST1200D	200 PSI DECAL (N/S)
3	1	LST550	1/2" LST SCREEN - 50 MESH
4	1	LSTM050B	MINI T-STRAINER BOWL
5	1	LSTM050G	MINI T-STRAINER GASKET
6	1	LSTM050H	1/2" NPT MINI T-STRAINER HEAD

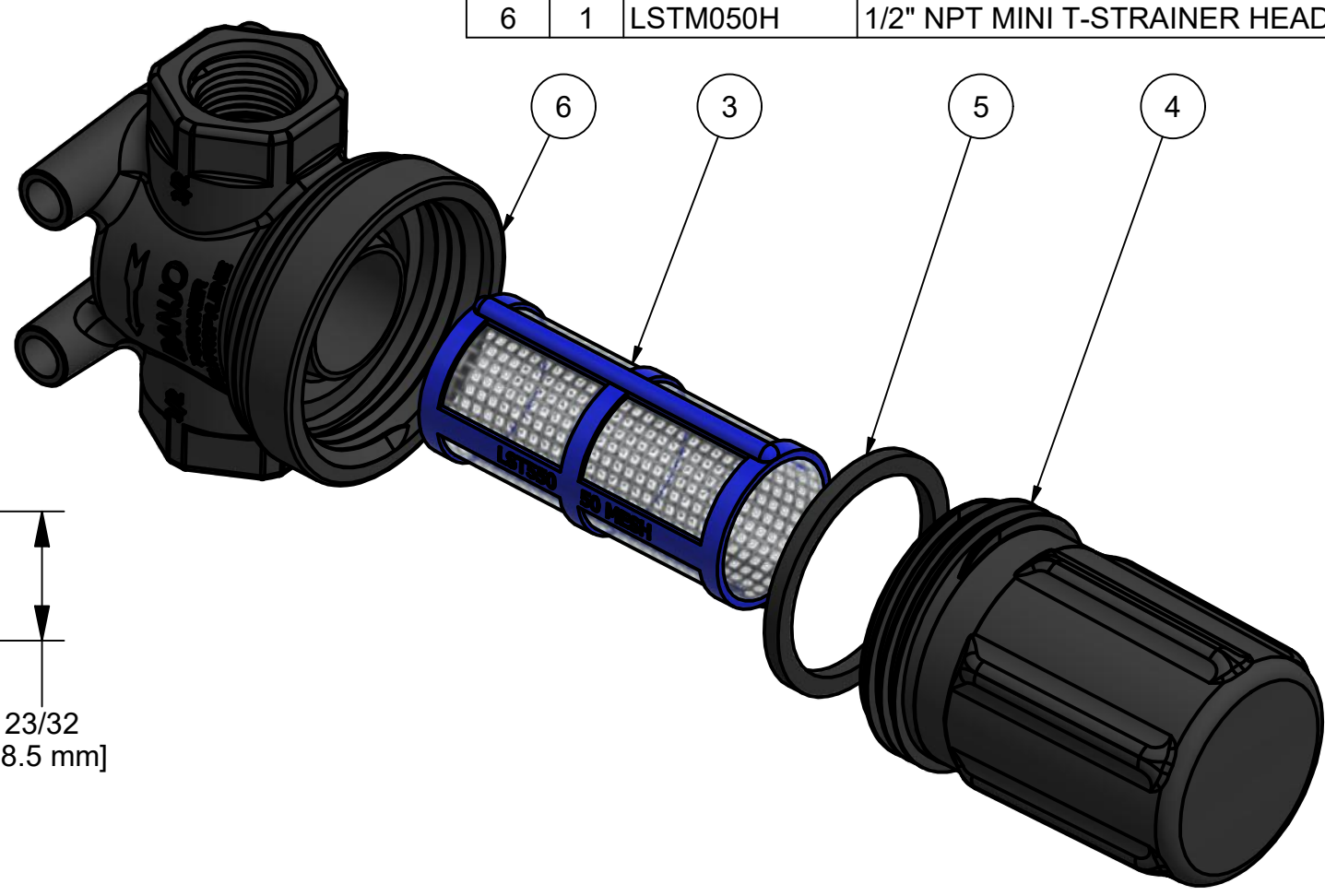
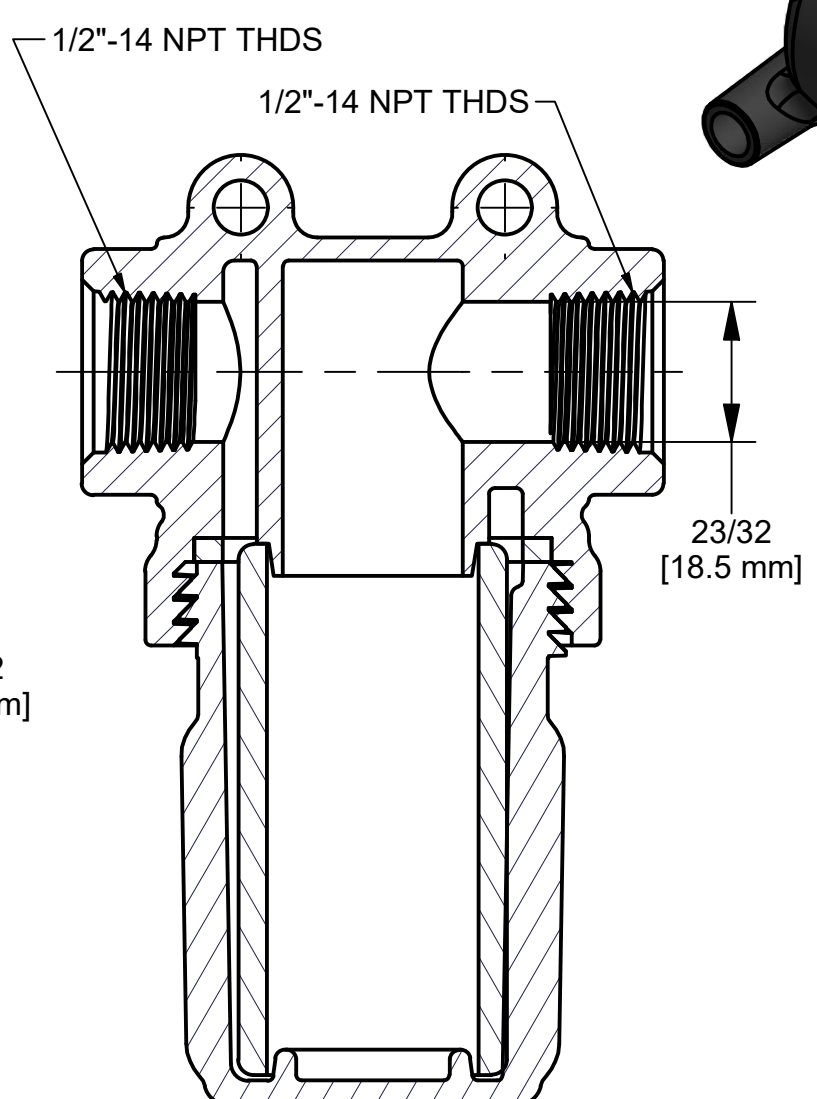
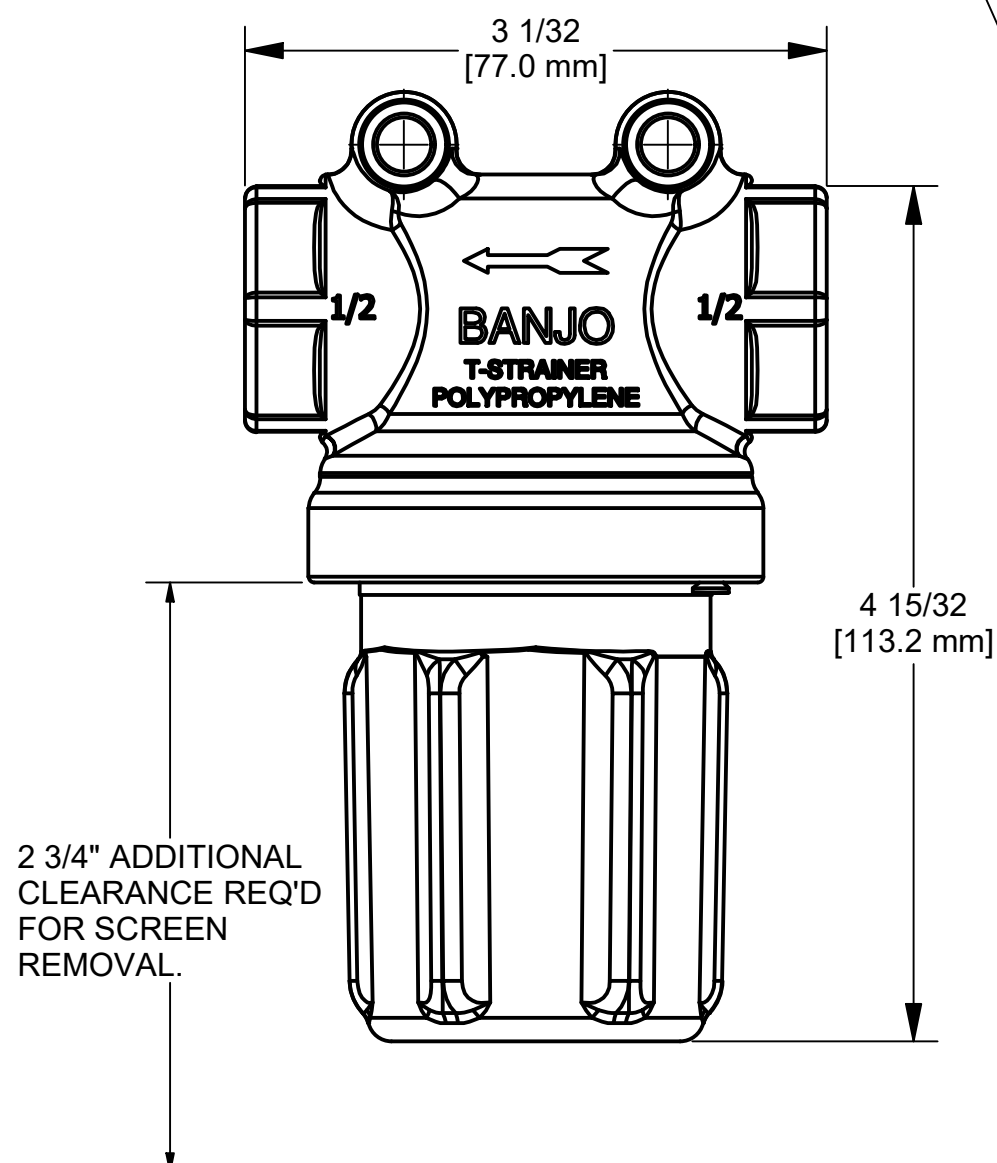

THIS DRAWING AND ALL INFORMATION CONTAINED THEREON ARE THE EXCLUSIVE PROPERTY OF BANJO CORPORATION.

UNLESS SPECIFICALLY NOTED, THIS DRAWING AND ITEMS SHOWN ON THIS DRAWING ARE SUBJECT TO CHANGE AT ANY TIME.

BANJO CORPORATION

150 BANJO DRIVE, CRAWFORDSVILLE, IN 47933
 WEB SITE: WWW.BANJOCORP.COM
 E-MAIL: BANJOSALES@IDEXCORP.COM

DESCRIPTION
 1/2" T-STRAINER - 50 MESH

PART NUMBER
 LSTM050-50