

PARTS LIST			
ITEM	QTY	PART NUMBER	DESCRIPTION
1	1	CE050D	1/2" CE LABEL (N/S)
2	1	LST1200D	200 PSI DECAL (N/S)
3	1	LST550	1/2" LST SCREEN - 50 MESH
4	1	LSTM050B	MINI T-STRAINER BOWL
5	1	LSTM050G	MINI T-STRAINER GASKET
6	1	LSTM075H	3/4" NPT MINI T-STRAINER HEAD

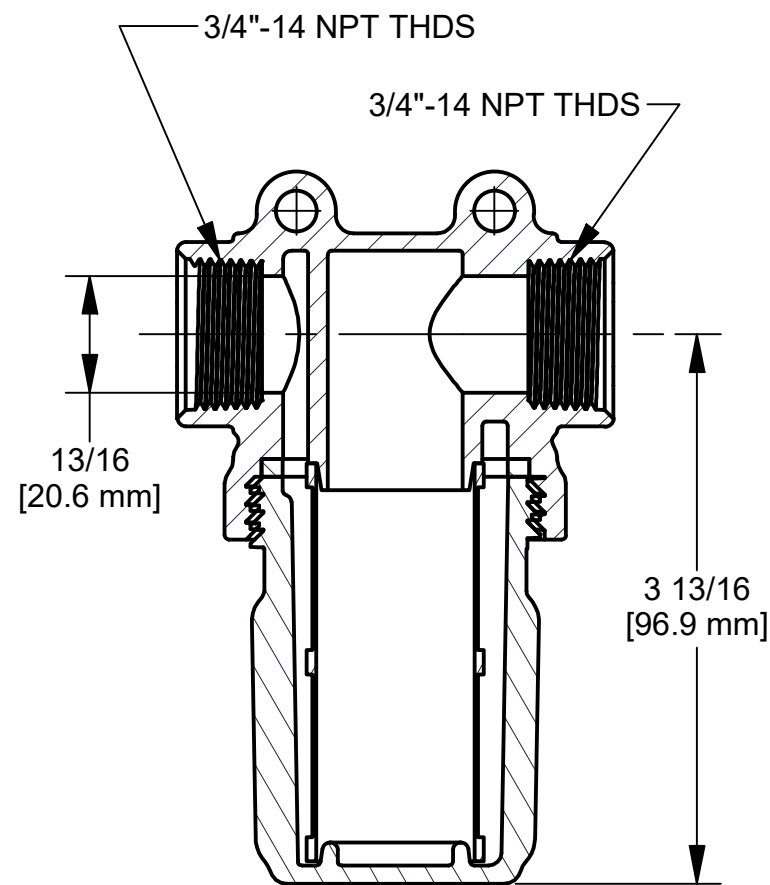

SECTION A-A
SCALE 3 / 4

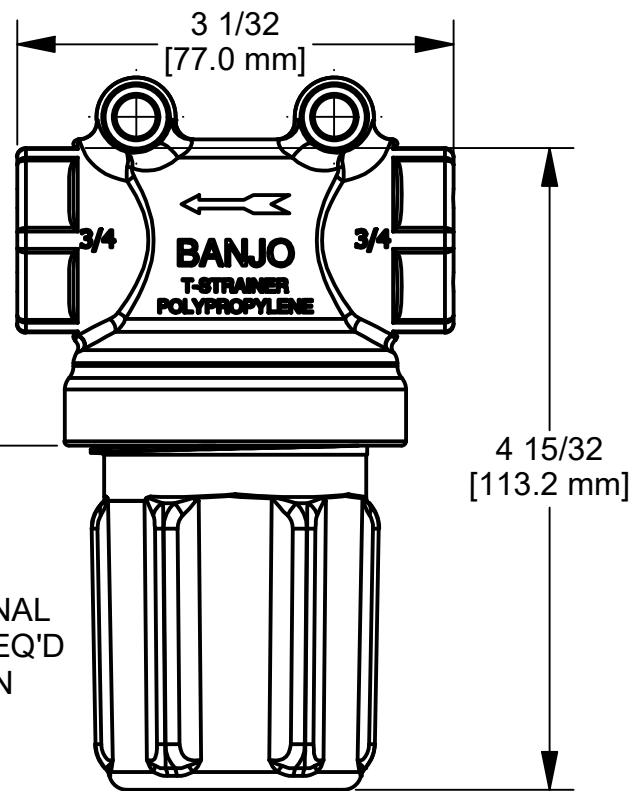
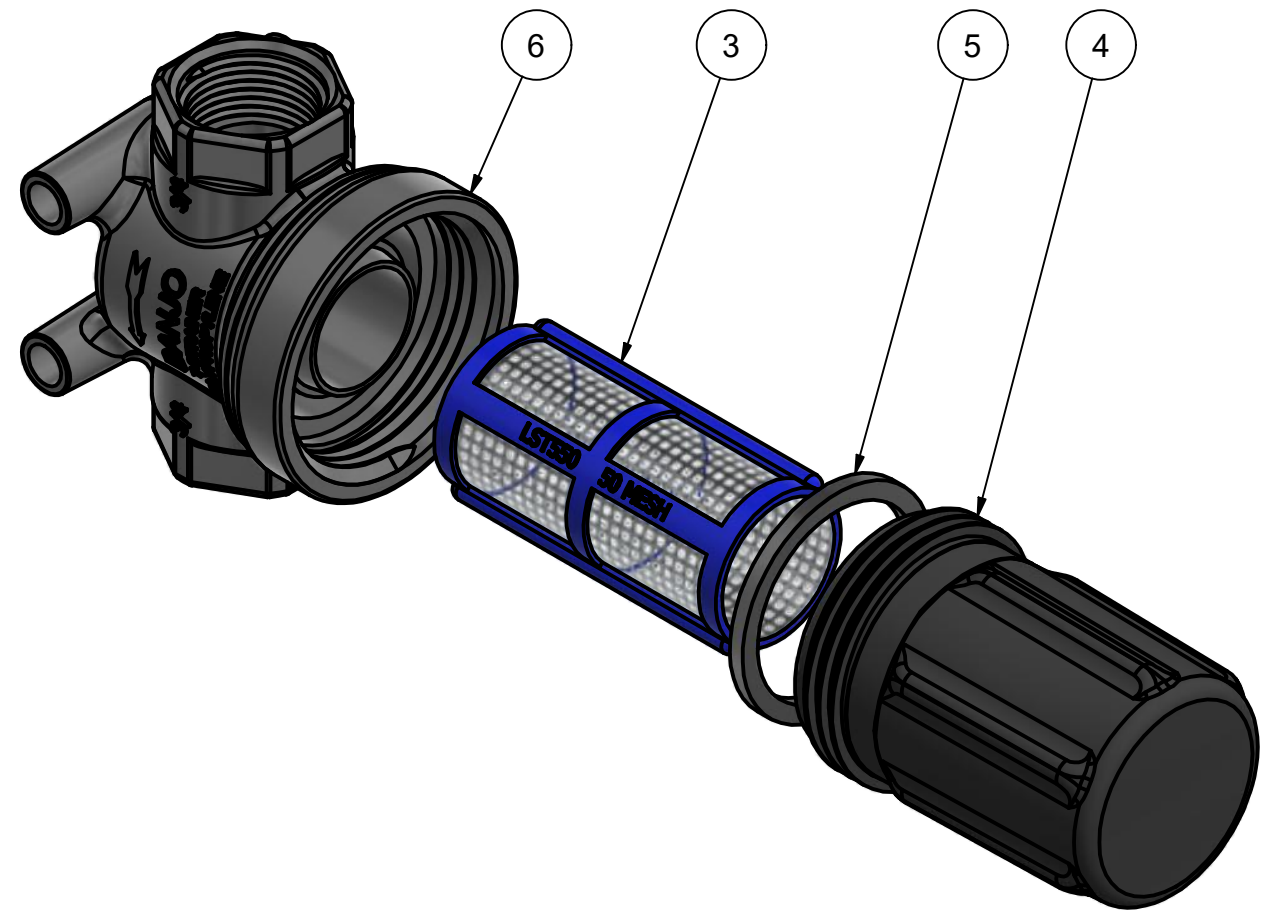

2 3/4" ADDITIONAL
CLEARANCE REQ'D
FOR SCREEN
REMOVAL

THIS DRAWING AND ALL
INFORMATION CONTAINED THEREON
ARE THE EXCLUSIVE PROPERTY OF
BANJO CORPORATION.

UNLESS SPECIFICALLY NOTED, THIS
DRAWING AND ITEMS SHOWN ON
THIS DRAWING ARE SUBJECT TO
CHANGE AT ANY TIME.



BANJO CORPORATION
150 BANJO DRIVE, CRAWFORDSVILLE, IN 47933
WEB SITE: WWW.BANJOCORP.COM
E-MAIL: BANJOSALES@IDEXCORP.COM

DESCRIPTION
3/4" MINI T-STRAINER - 50 MESH

PART NUMBER
LSTM075-50