

Assembly Specs:
 Body Bolt Tightening Torque: 75 in-lbs
 Max stem turning torque: 50 in-lbs
 Max amp Draw: 3 amp

PARTS LIST			
ITEM	QTY	PART NUMBER	DESCRIPTION
1	1	EV3300	3/4 Sec, 3 Wire, EV Actuator Assy
2	1	FC100	1" HI TORQUE CLAMP
3	1	MEV100XR1	1" Manifold Valve SubAssy
4	1	MVE004	MVE Mounting Breather
5	3	VE001	CABLE SEAL
6	3	VE002	MALE TERMINAL
7	1	VE003	3 Conductor Female Shroud

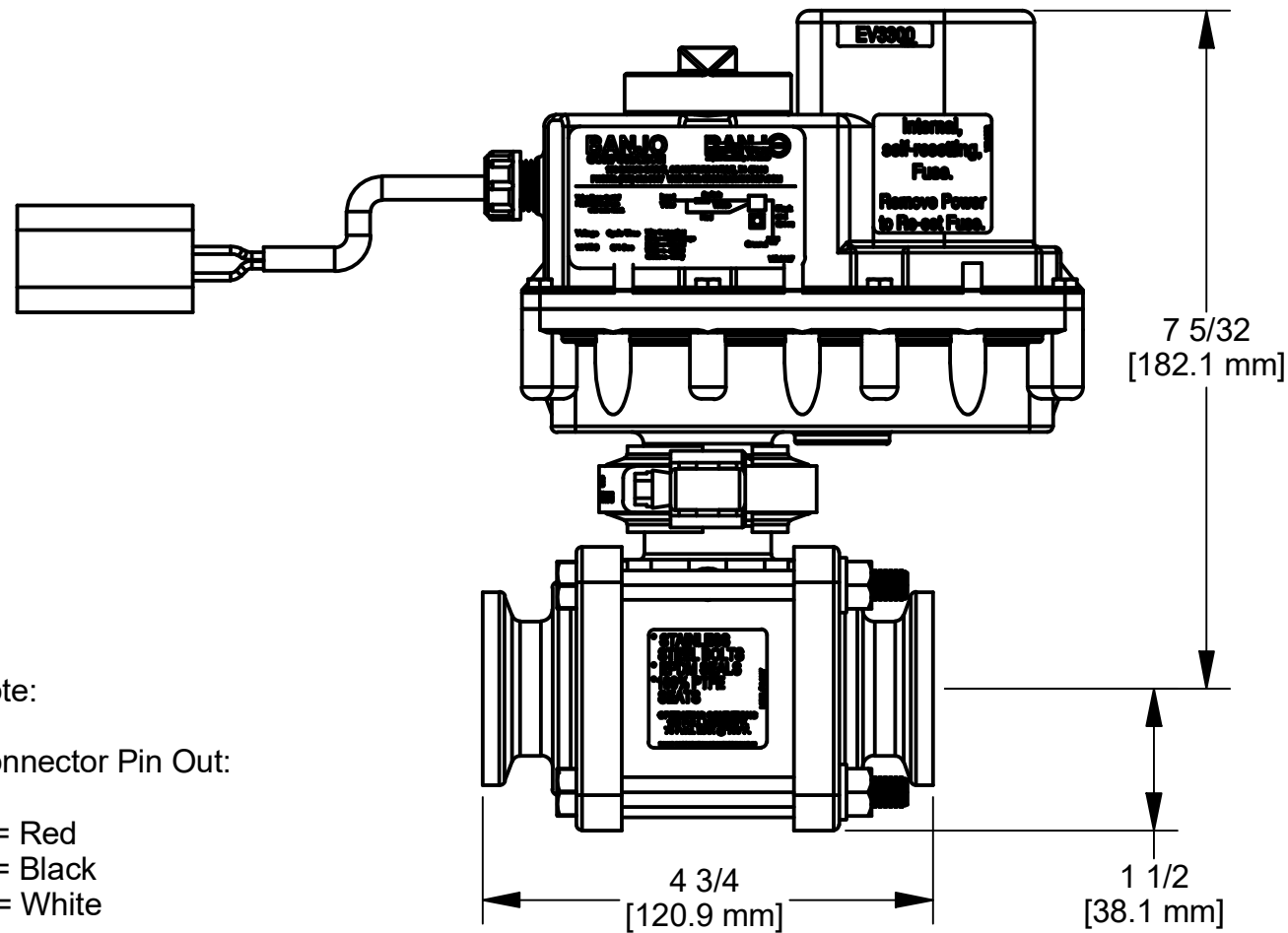
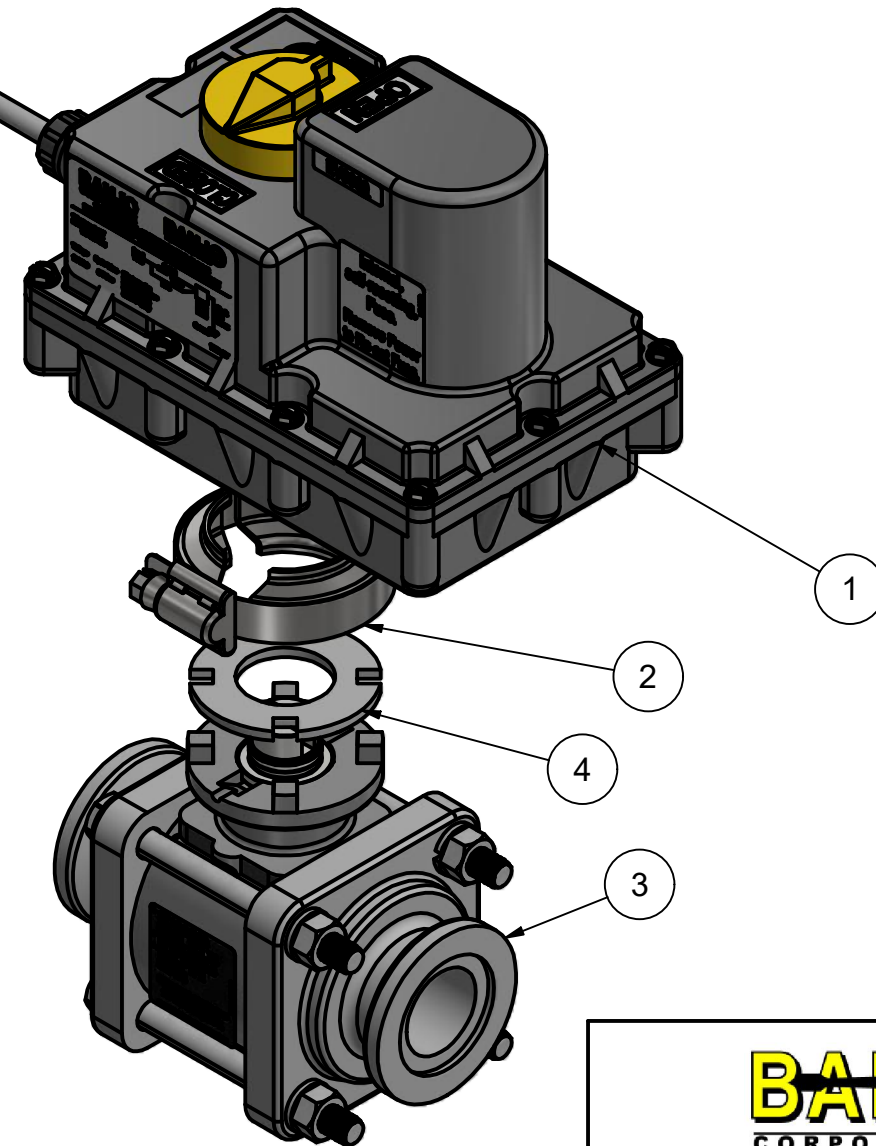
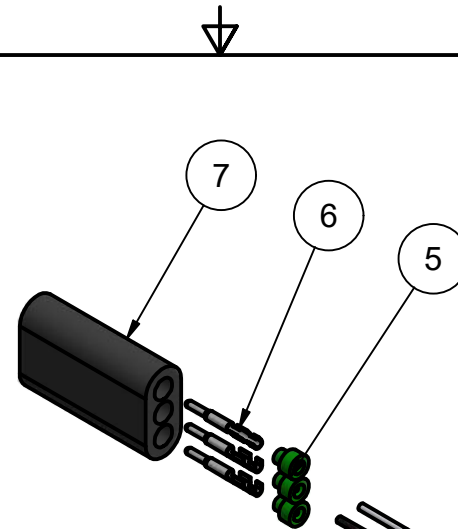
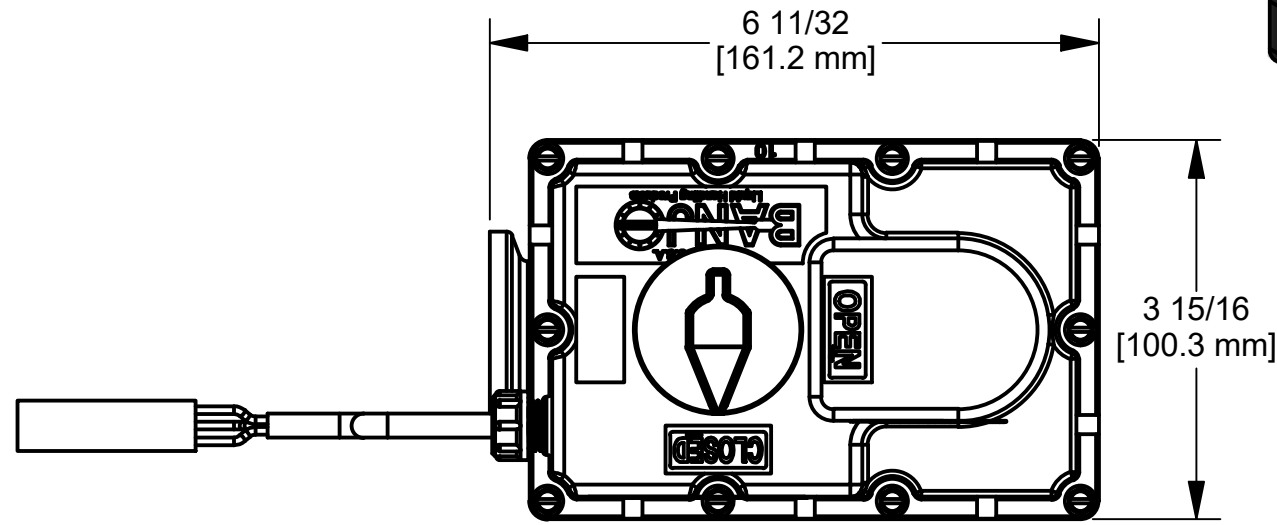

Note:
 Connector Pin Out:
 A = Red
 B = Black
 C = White

THIS DRAWING AND ALL INFORMATION CONTAINED THEREON ARE THE EXCLUSIVE PROPERTY OF BANJO CORPORATION.

UNLESS SPECIFICALLY NOTED, THIS DRAWING AND ITEMS SHOWN ON THIS DRAWING ARE SUBJECT TO CHANGE AT ANY TIME.



BANJO CORPORATION
 150 BANJO DRIVE, CRAWFORDSVILLE, IN 47933
 WEB SITE: WWW.BANJOCORP.COM
 E-MAIL: BANJOSALES@IDEXCORP.COM

DESCRIPTION
 1" MNFLD EV 3/4 Sec, 3W, ON/OFF w/
 CNCTR

PART NUMBER
MEV101CF