

| Parts List | | | |
|------------|-----|-------------|---------------------------------|
| ITEM | QTY | PART NUMBER | DESCRIPTION |
| 1 | 1 | AQ206V | #206 QUAD RING, FKM |
| 2 | 1 | EVP20151A | EVX VALVE SS STEM 1-2"SP BOLTED |
| 3 | 1 | MEVX20354AS | 2" SL VE BODY |
| 4 | 4 | V20017 | 3/8-16 X 4" HHCS |
| 5 | 4 | V20018 | 3/8" LOCKWASHER |
| 6 | 4 | V20019 | 3/8" HEX NUT |
| 7 | 2 | VE20258A | 2" VE Seat TFM |
| 8 | 2 | VE20264 | 2-150 O'RING, FKM |
| 9 | 2 | VE20294A | 2" Manifold EV Endplate |
| 10 | 1 | VE20355 | 2" VE 3-Way SS Ball |

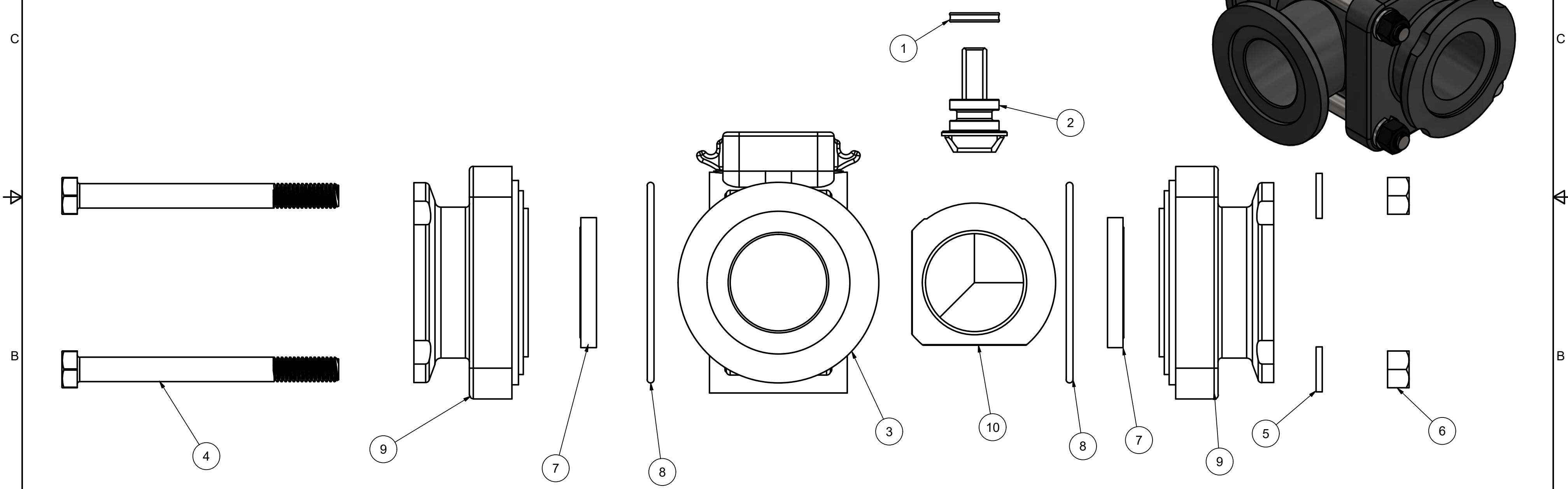
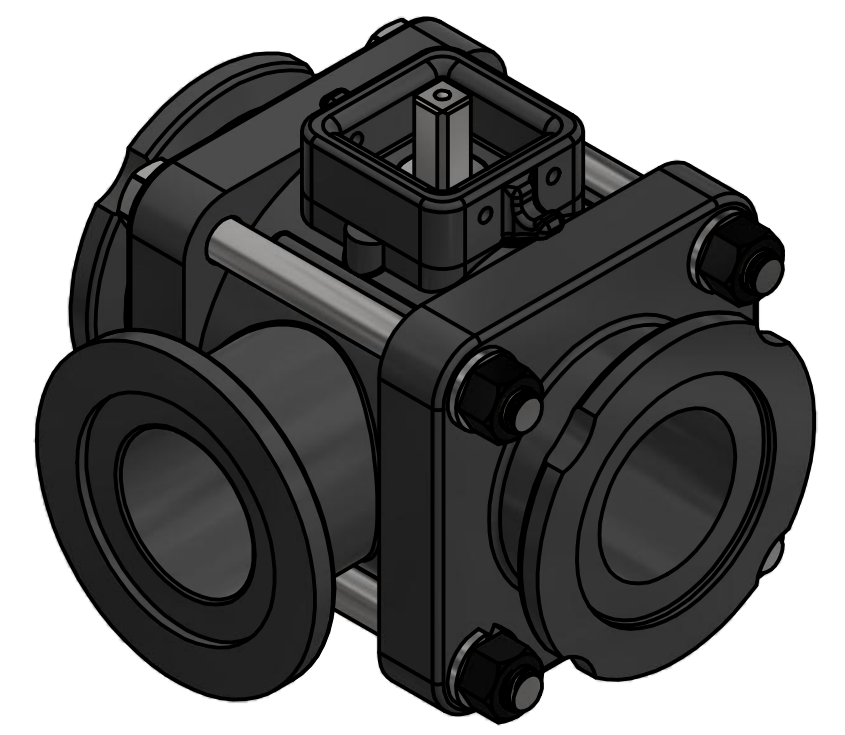

ASSEMBLY SPECS:
 BODY BOLT TIGHTENING TORQUE: 75 IN-LB
 MAX STEM TURNING TORQUE: 75 IN-LB

THIS DRAWING AND ALL INFORMATION CONTAINED THEREON ARE THE EXCLUSIVE PROPERTY OF BANJO CORPORATION.

 UNLESS SPECIFICALLY NOTED, THIS DRAWING AND ITEMS SHOWN ON THIS DRAWING ARE SUBJECT TO CHANGE AT ANY TIME.



BANJO CORPORATION

BANJO CORPORATION
 150 BANJO DRIVE, CRAWFORDSVILLE, IN 47933
 WEB SITE: WWW.BANJOCORP.COM
 E-MAIL: BANJOSALES@IDEXCORP.COM

DESCRIPTION
 MEVX 2" SL VALVE ONLY

PART NUMBER
MEVX200SLX