

NOTE:
PIN OUT / WIRING, 3 WIRE

PIN 1 = BLACK = GROUND
PIN 2 = RED = +12 VDC
PIN 3 = WHITE = SIGNAL

WIRE LENGTH = 18" (450 mm)

Parts List			
ITEM	QTY	PART NUMBER	DESCRIPTION
1	1	050DECAL	Banjo Logo Decal
2	1	12717	#11 O'RING, EPDM
3	1	12724	#14 O'RING
4	1	A035	2-035 O-ring, EPDM
5	1	LEV4000	1/3 SEC 3 WIRE LEV ACTUATOR
6	1	MLEV100AX	1/2" MLEV w/ M100 Valve Only Assy, SS Ball
7	1	VE024	AMP RUBBER BOOT 880811-2
8	1	VE025	AMP 3 PIN TAB CONNECTOR 282105-1
9	3	VE026	AMP MINI MIC TAB 183024-1
10	3	VE027	AMP SINGLE WIRE SEAL 281934-2
11	4	VE15220	#6x3/4"18-8SS HWH SMS

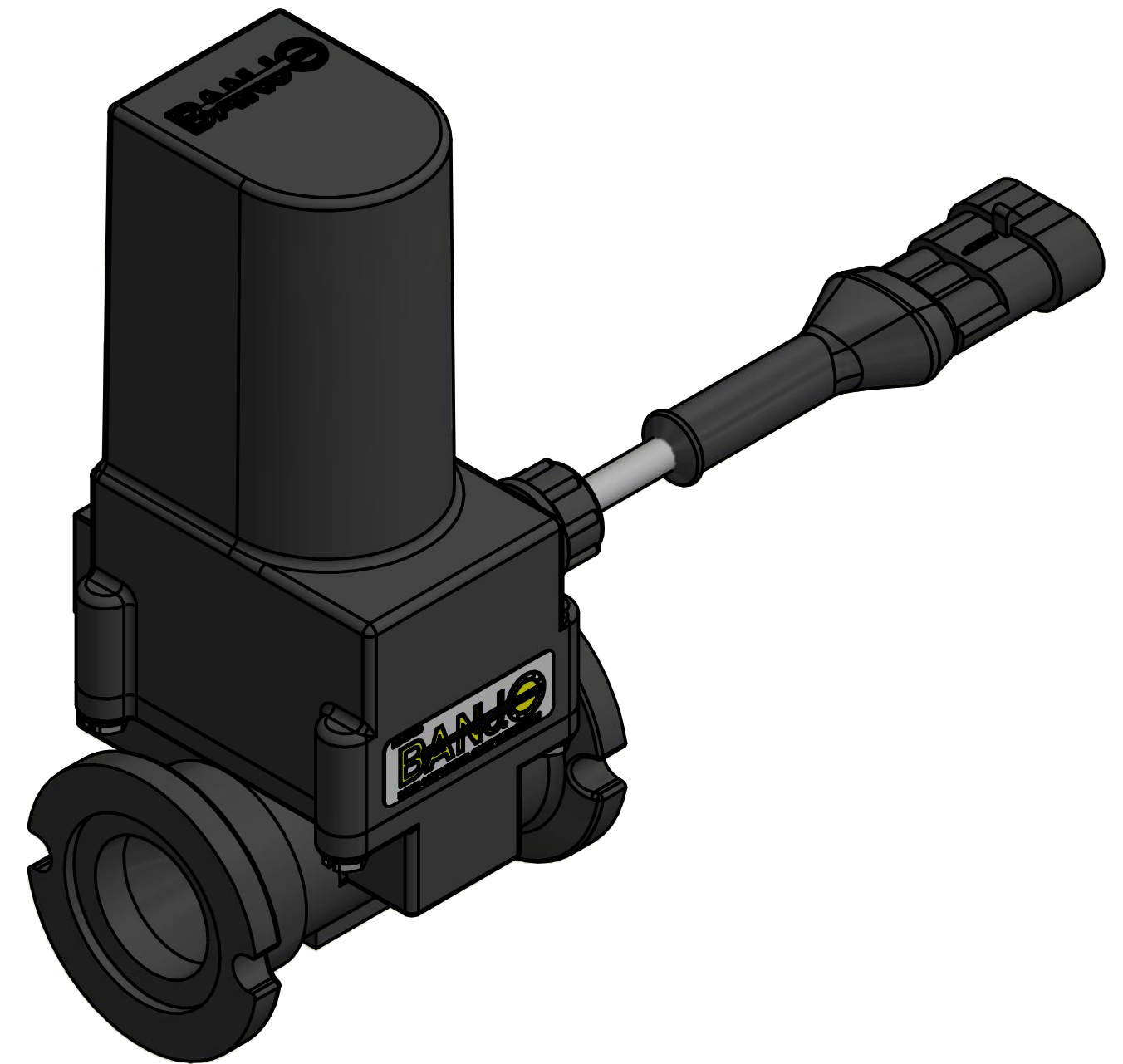

THIS DRAWING AND ALL INFORMATION CONTAINED THEREON ARE THE EXCLUSIVE PROPERTY OF BANJO CORPORATION.
UNLESS SPECIFICALLY NOTED, THIS DRAWING AND ITEMS SHOWN ON THIS DRAWING ARE SUBJECT TO CHANGE AT ANY TIME.

BANJO CORPORATION

150 BANJO DRIVE, CRAWFORDSVILLE, IN 47933
WEB SITE: WWW.BANJOCORP.COM
E-MAIL: SALES1@BANJOCORP.COM

DESCRIPTION
1/2" MLEV w/ M100 Valve, 3 Wire, SS Ball
PART NUMBER
MLEV100A