

8 7 6 5 4 3 2 1

Parts List			
ITEM	QTY	PART NUMBER	DESCRIPTION
1	1	LSQ200-PL	1" NPT LINE STRAINER PLUG
2	1	LSQ200-RV	AS568A -123 O-RING, FKM, BROWN
4	1	MLS220C1X	2" FP MLS CAP
5	1	MLS220G1V	AS568A -241 O-RING, FKM, BROWN
6	1	MLS220R1	2" FP LS RETAINING RING
7	1	MLS222BI	MLS222 BODY WITH RIBS & INSERTS
8	1	MLS250SS	2" LST SCREEN 50 MESH W/ PERF SUPPORT

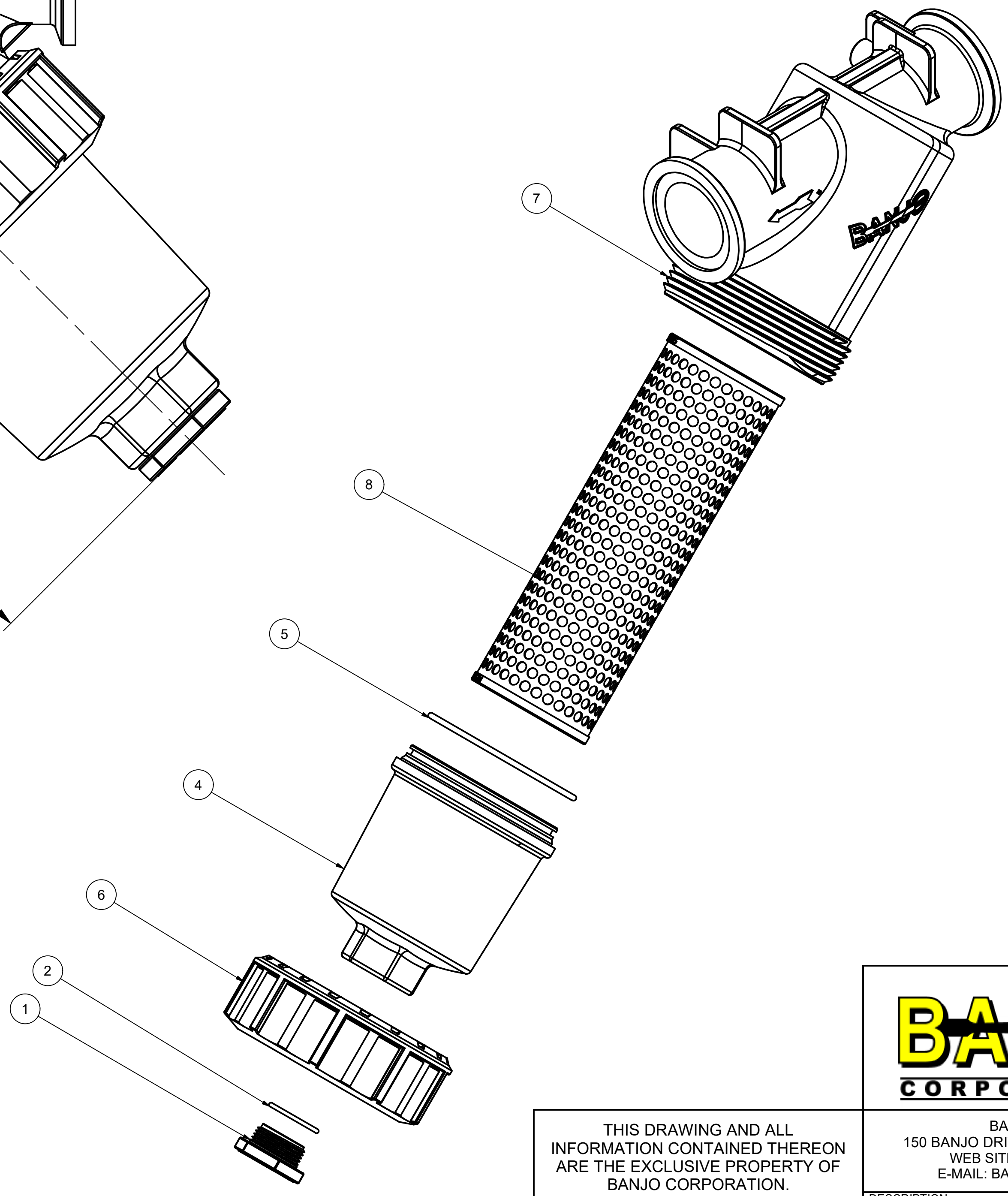
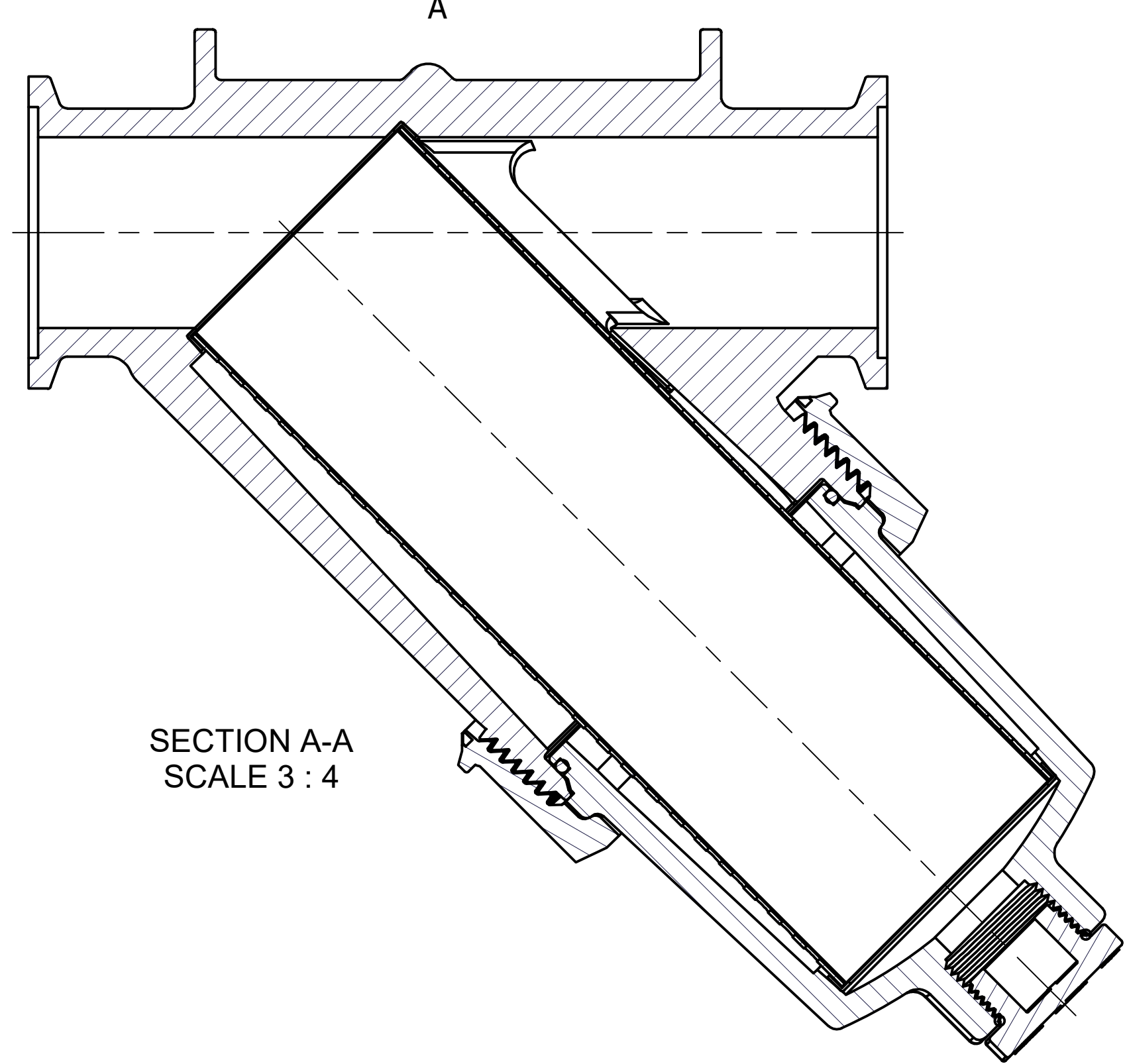
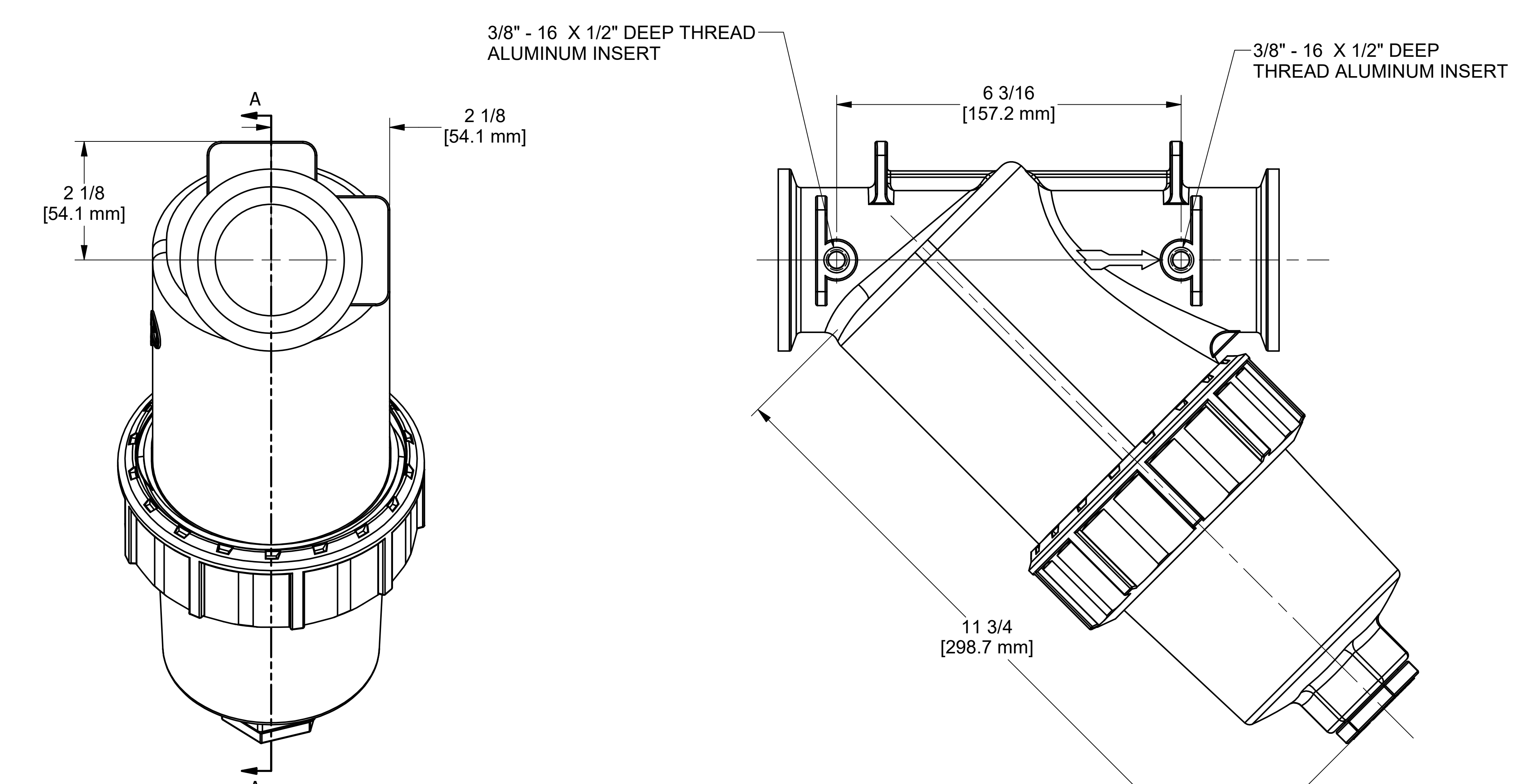

THIS DRAWING AND ALL INFORMATION CONTAINED THEREON ARE THE EXCLUSIVE PROPERTY OF BANJO CORPORATION.

UNLESS SPECIFICALLY NOTED, THIS DRAWING AND ITEMS SHOWN ON THIS DRAWING ARE SUBJECT TO CHANGE AT ANY TIME.

BANJO CORPORATION
 150 BANJO DRIVE, CRAWFORDSVILLE, IN 47933
 WEB SITE: WWW.BANJO.CORP.COM
 E-MAIL: BANJOSALES@IDEXCORP.COM

DESCRIPTION
2"FP MANIFOLD Y STRAINER-50M FKM

PART NUMBER
MLS222I-50V

8 7 6 5 4 3 2 1