

Parts List			
ITEM	QTY	PART NUMBER	DESCRIPTION
1	1	LST150-B	1 1/2" T-Strainer Bowl Assembly
2	1	LST150-G	#336 O-RING
3	1	LST15100	1 1/2" LST SCREEN - 100 MESH
4	1	LST225D	DECAL (N/S)
5	1	MLST150-H	2" MANIFOLD T-STRAINER HEAD

Note:
Additional Clearance Req'd
for Screen Removal: 8"

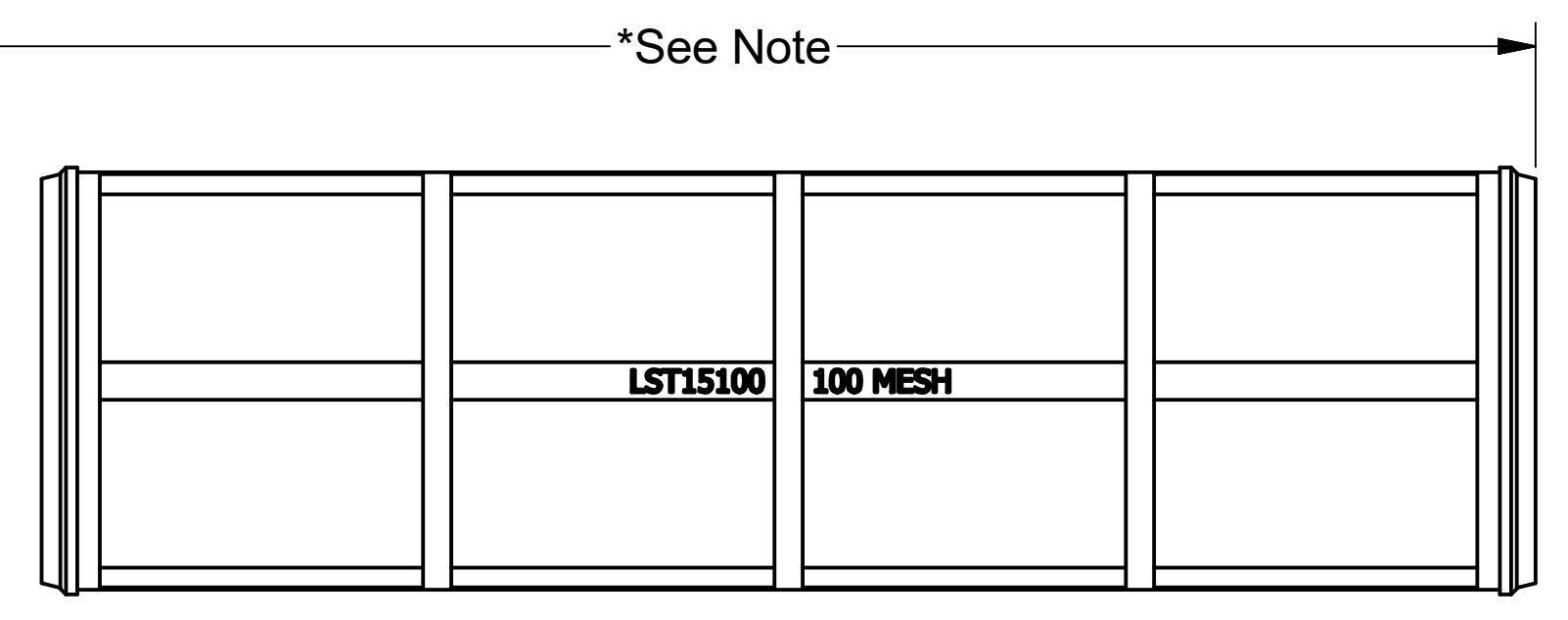

*See Note

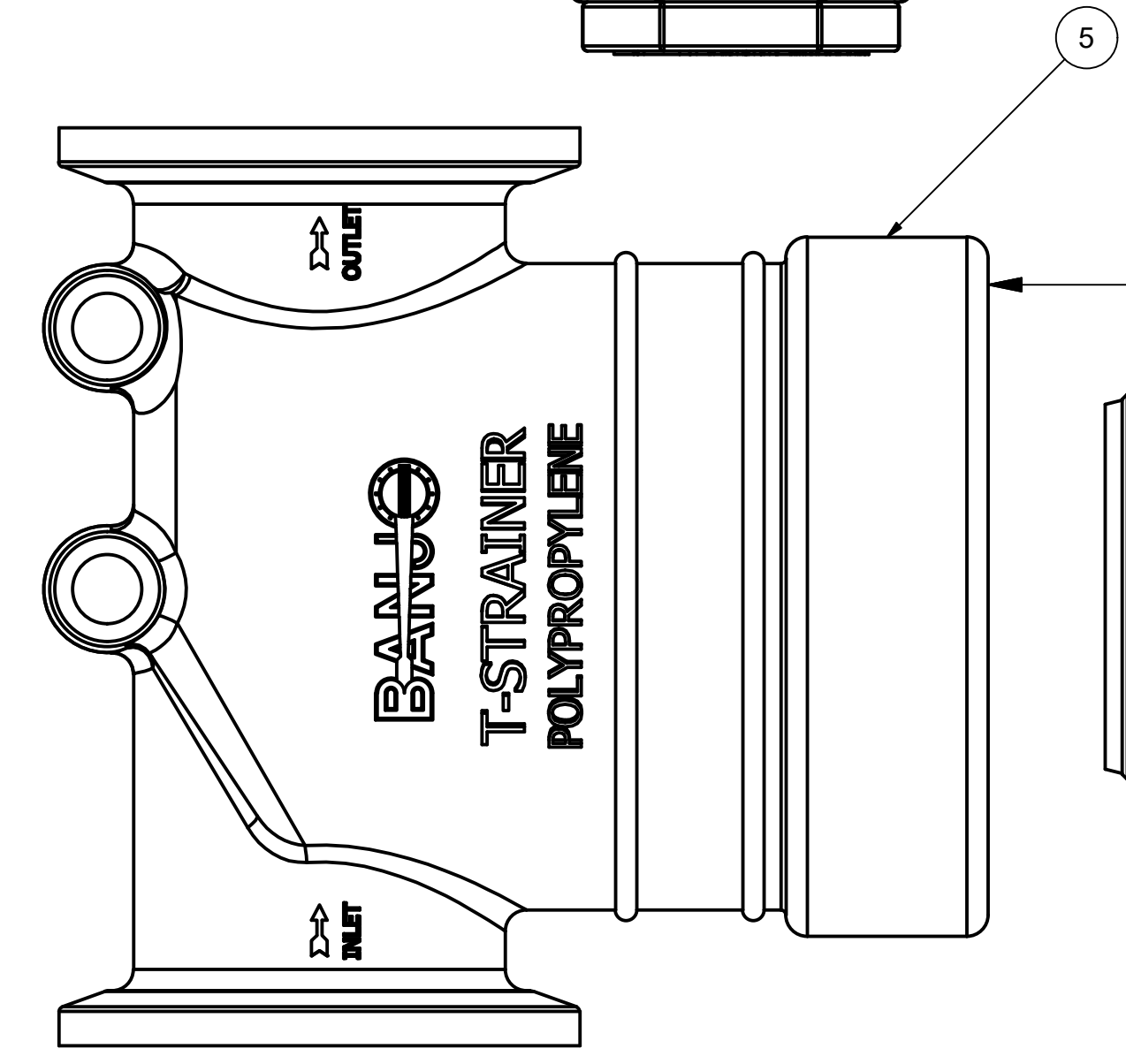
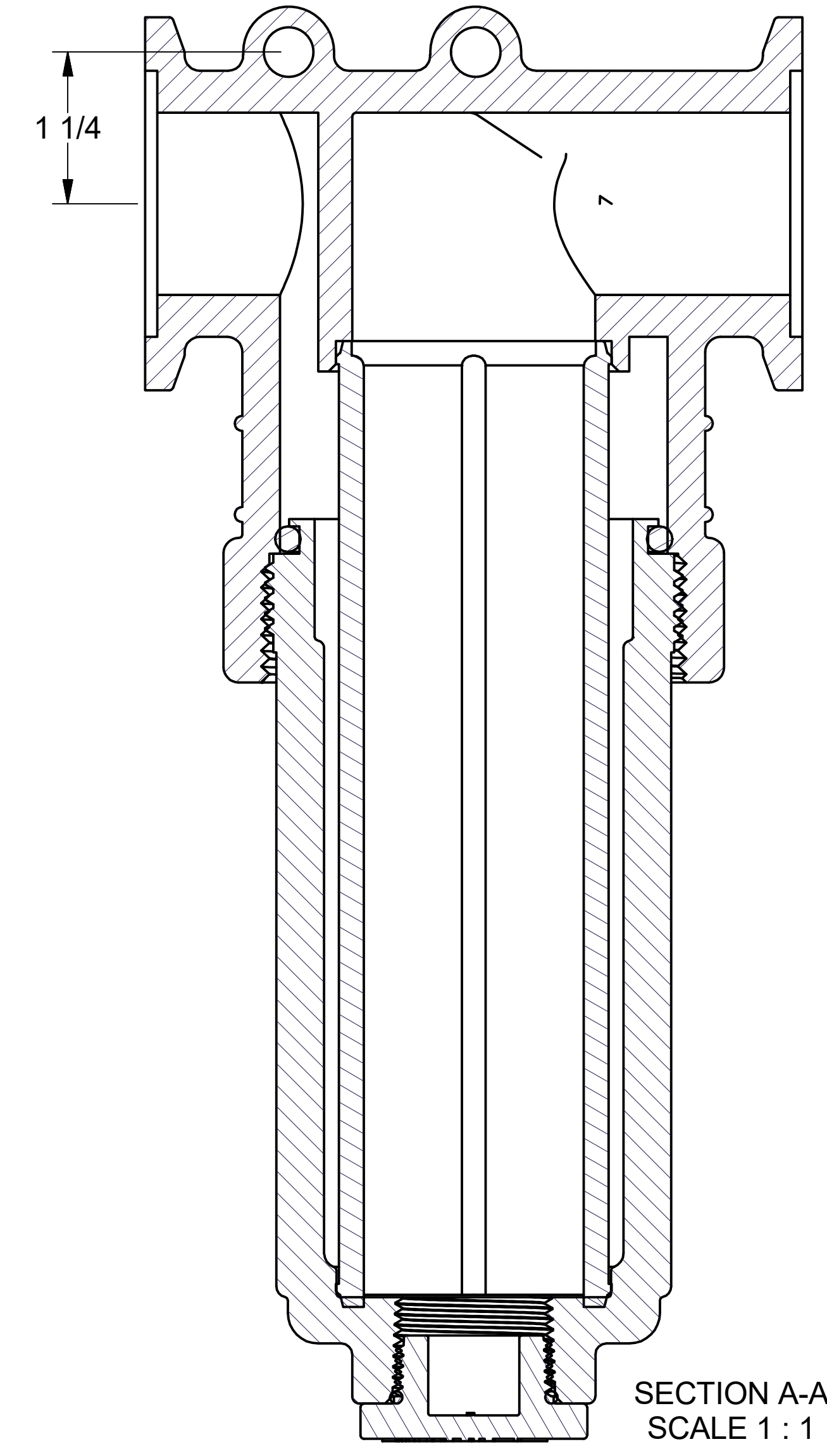
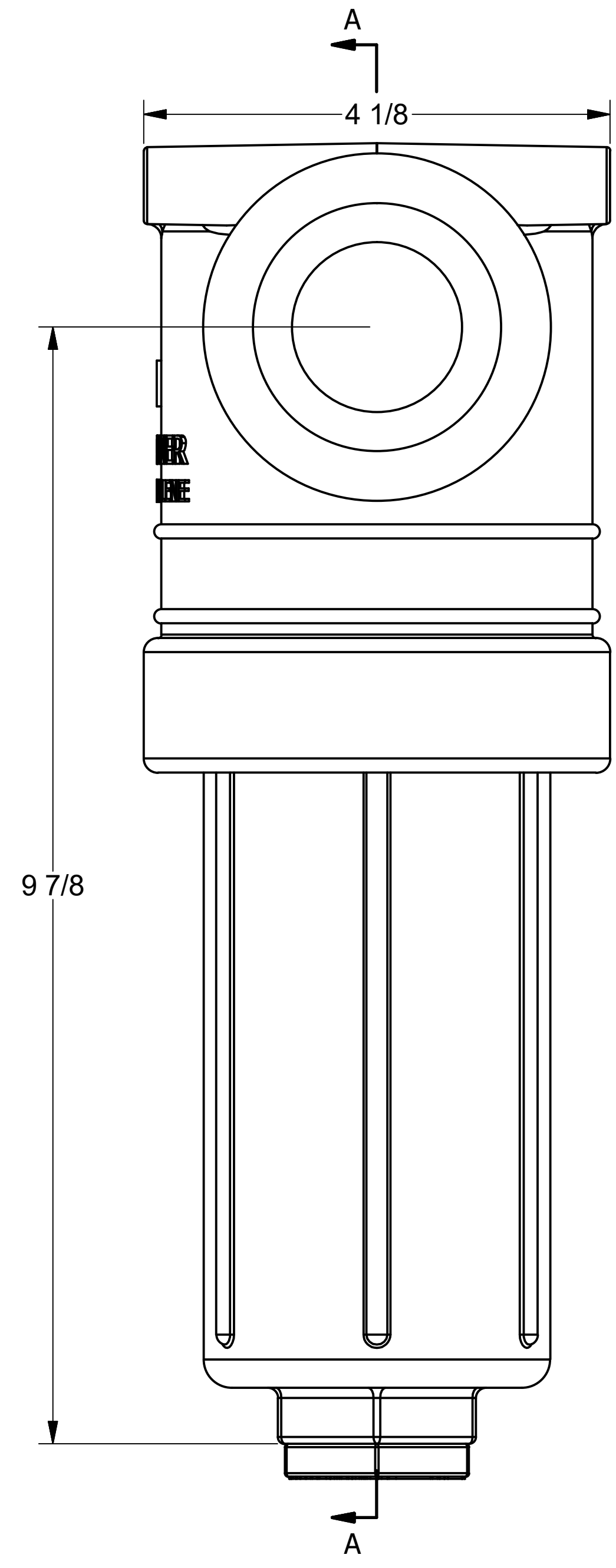
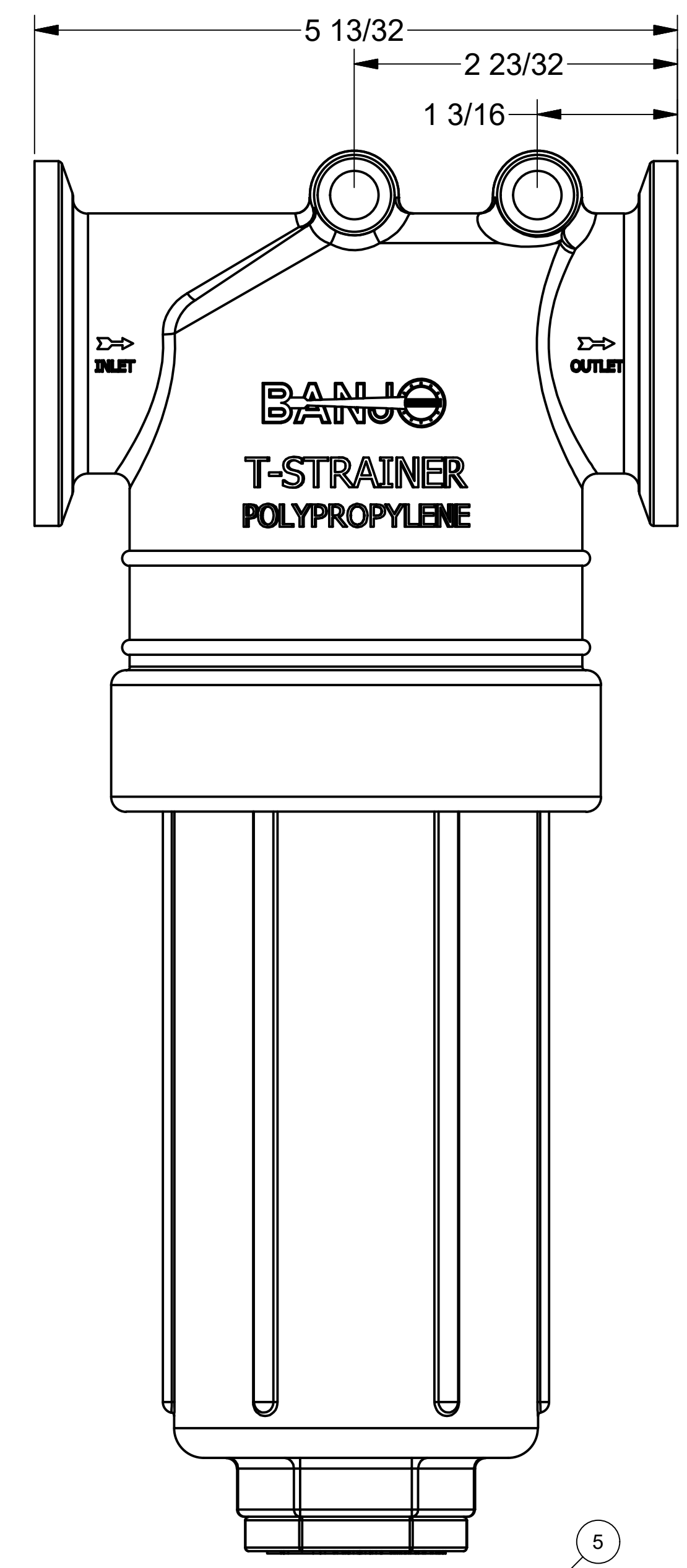
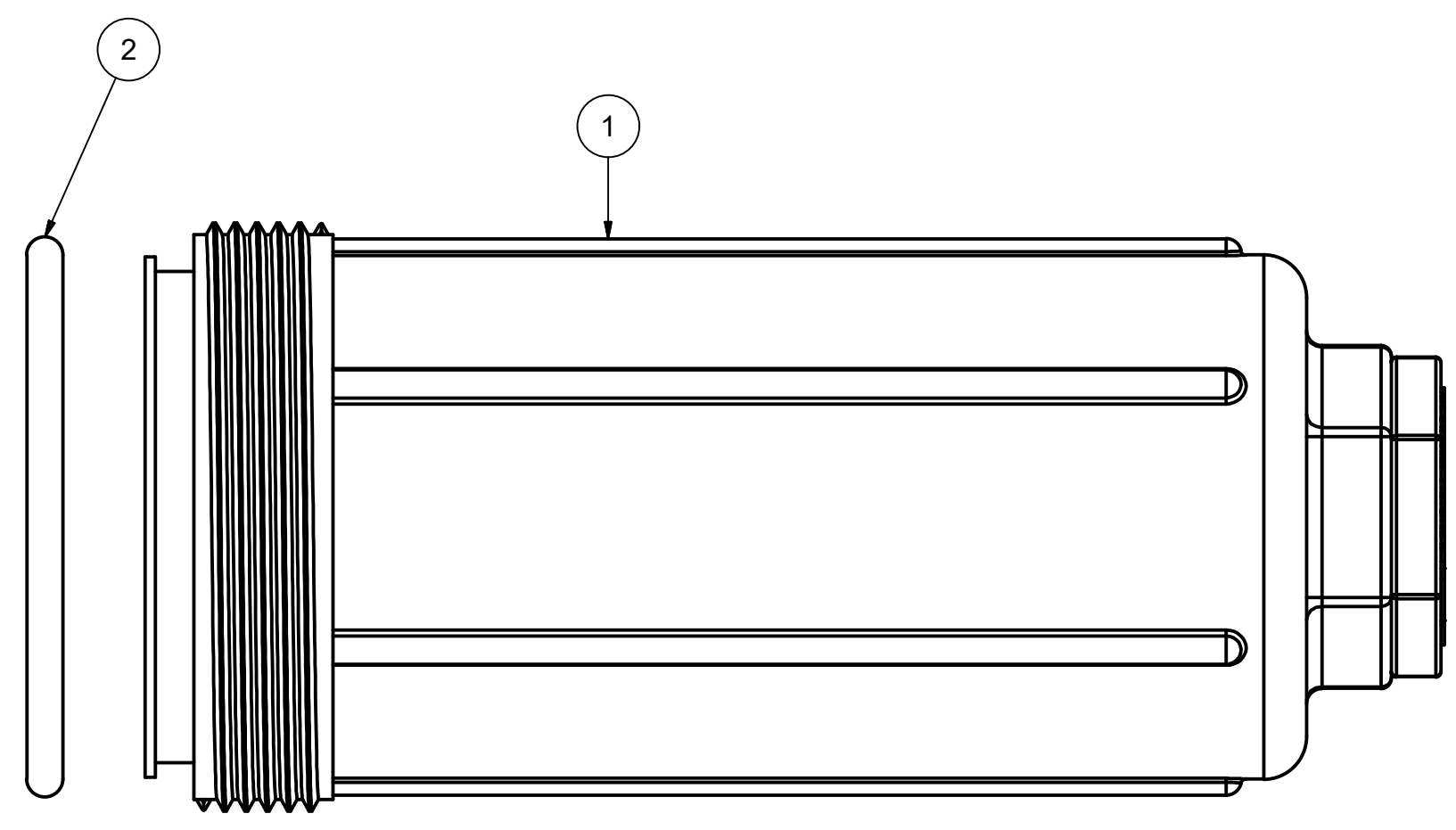

THIS DRAWING AND ALL INFORMATION CONTAINED THEREON ARE THE EXCLUSIVE PROPERTY OF BANJO CORPORATION.
UNLESS SPECIFICALLY NOTED, THIS DRAWING AND ITEMS SHOWN ON THIS DRAWING ARE SUBJECT TO CHANGE AT ANY TIME.

BANJO CORPORATION
150 BANJO DRIVE, CRAWFORDSVILLE, IN 47933
WEB SITE: WWW.BANJOCORP.COM
E-MAIL: SALES1@BANJOCORP.COM

DESCRIPTION
2" Manifold T Line Strainer, 100 Mesh

PART NUMBER
MLST150-100