

SECTION B-B
SCALE 3 / 4

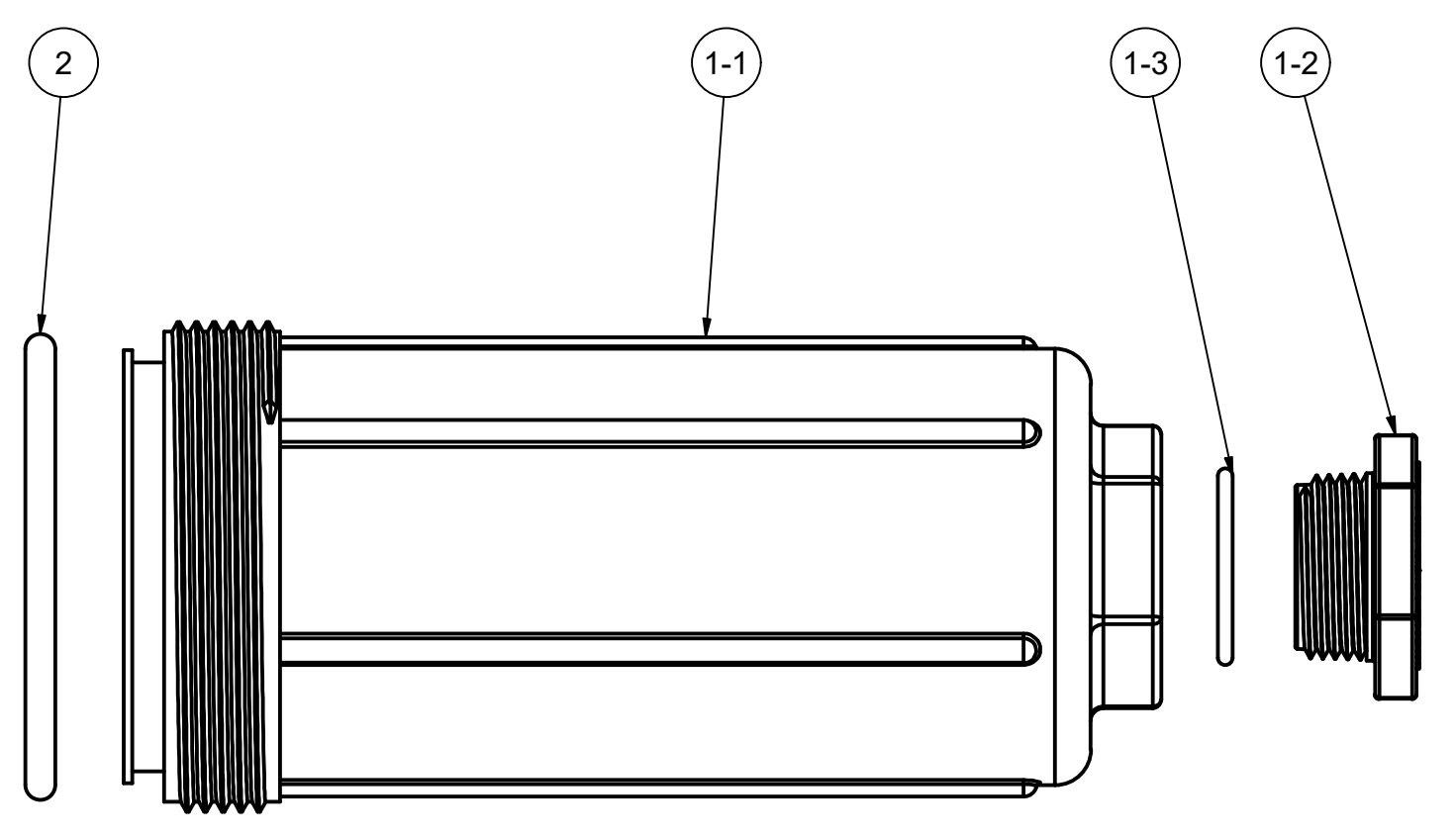

PARTS LIST			
ITEM	QTY	PART NUMBER	DESCRIPTION
1	1	LST150-BV	1 1/2" T-Strainer Bowl Assembly, FKM
1-2	1	LSQ200-PL	LINE STRAINER PLUG
1-3	1	LSQ200-RV	2-123 FKM O-RING
1-1	1	LST150-XB	1 1/2" T-STRAINER BOWL
1-4	1	VL1005	FKM LABEL (N/S)
2	1	LST150-GV	AS568A -336 O-RING, FKM, BROWN
3	1	LST1580	1 1/2" LST SCREEN - 80 MESH
4	1	LST225D	DECAL (N/S)
5	1	MLST150-H	1-1/2"STRNR W/2" MANIFOLD CONN

NOTE:
ADDITIONAL CLEARANCE REQ'D FOR SCREEN REMOVAL: 8"

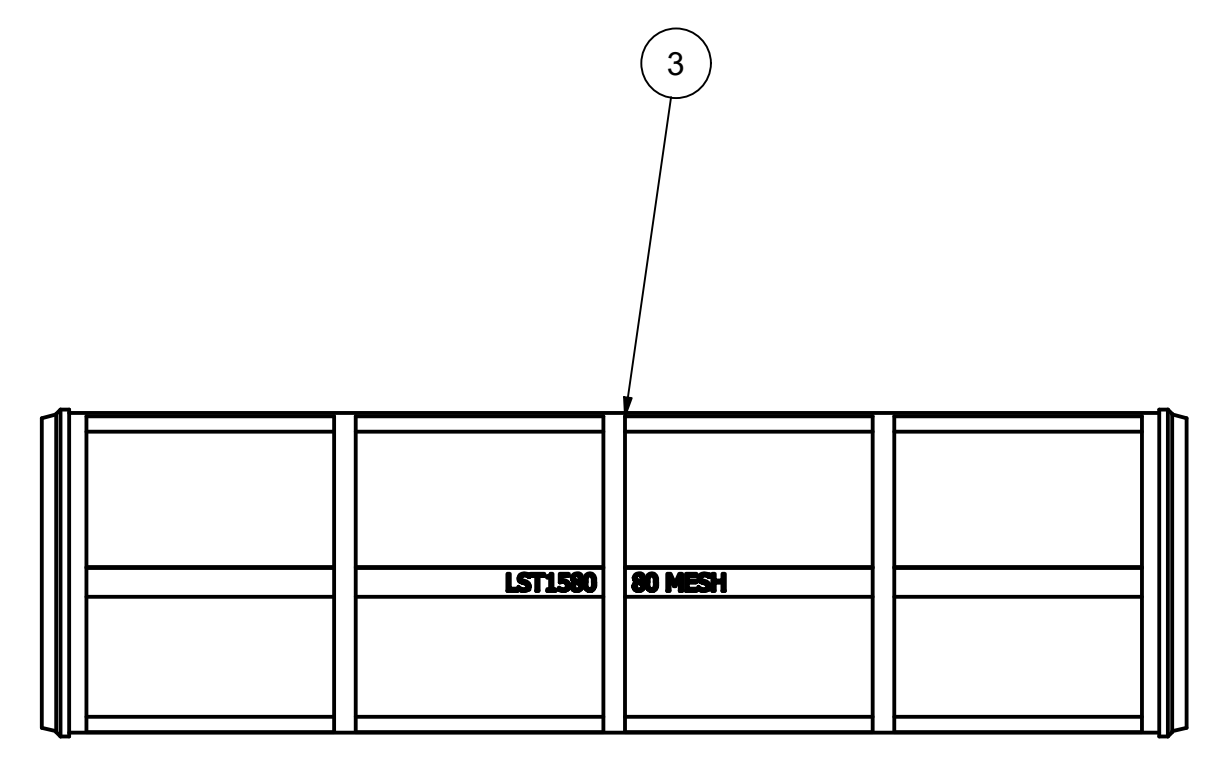
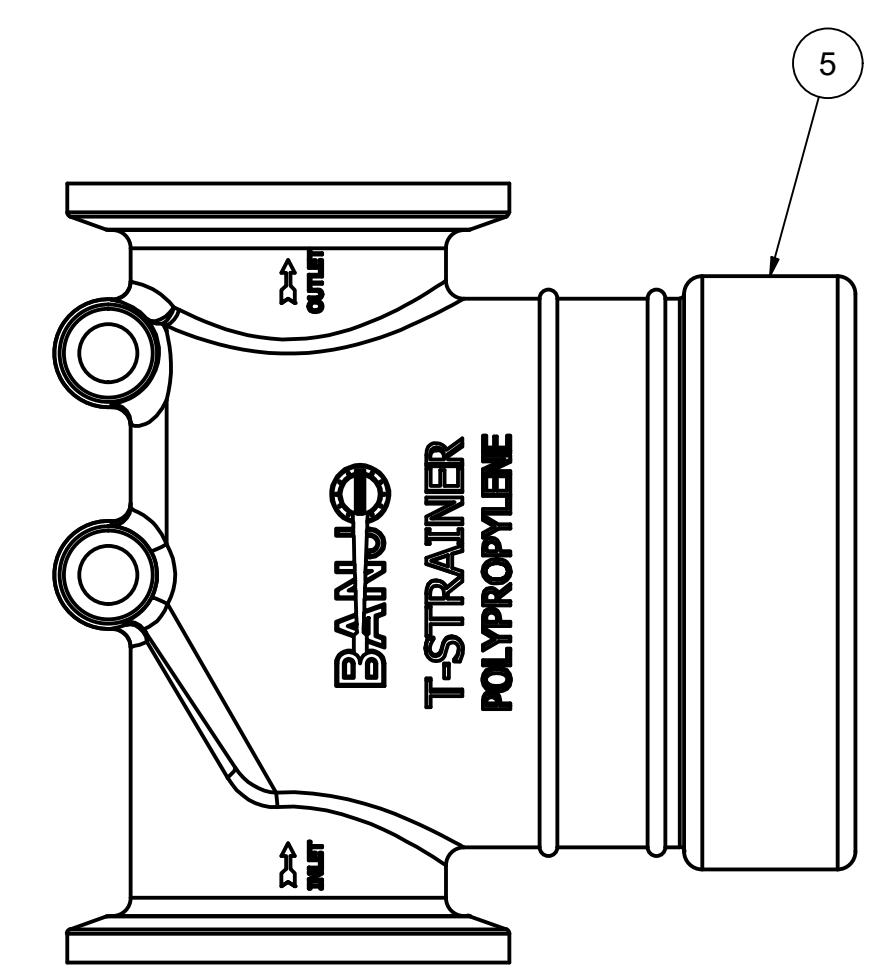
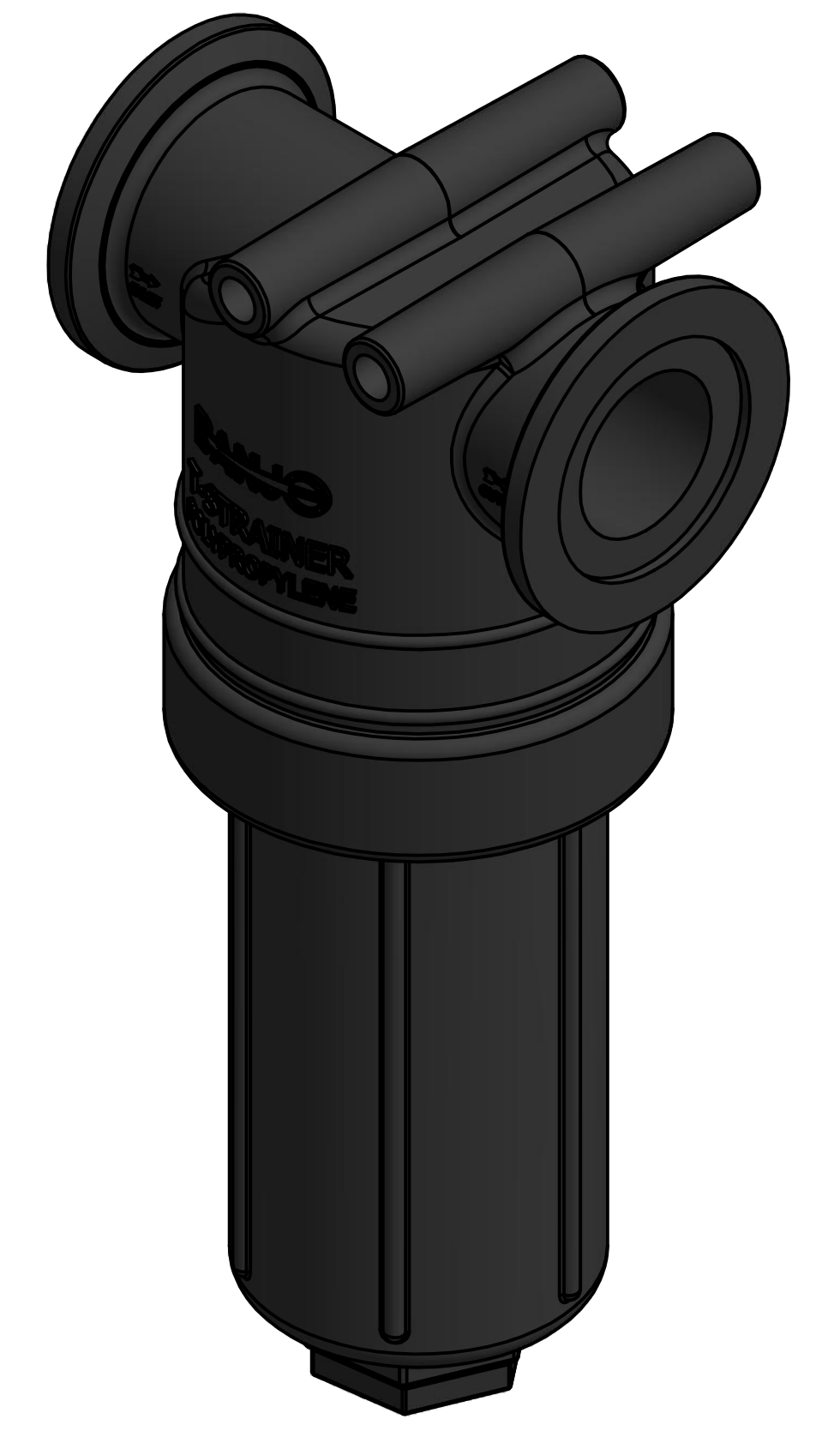

THIS DRAWING AND ALL INFORMATION CONTAINED THEREON ARE THE EXCLUSIVE PROPERTY OF BANJO CORPORATION.
UNLESS SPECIFICALLY NOTED, THIS DRAWING AND ITEMS SHOWN ON THIS DRAWING ARE SUBJECT TO CHANGE AT ANY TIME.

BANJO CORPORATION 150 BANJO DRIVE, CRAWFORDSVILLE, IN 47933 WEB SITE: WWW.BANJO.CORP.COM E-MAIL: BANJOSALES@IDEXCORP.COM	
DESCRIPTION	2" MNFD T-STRAINER 80 MESH, FKM
PART NUMBER	MLST150-80V