

Parts List			
ITEM	QTY	PART NUMBER	DESCRIPTION
1	1	LST1300D	300 PSI DECAL (N/S)
2	1	LST580	1/2" LST SCREEN - 80 MESH
3	1	LSTM050B	MINI T-STRAINER BOWL
4	1	LSTM050G	MINI T-STRAINER GASKET
5	1	MLSTM100H	1" MNFLD MINI T-STRAINER HEAD

NOTE:  
ADDITIONAL CLEARANCE REQ'D  
FOR SCREEN REMOVAL: 2 3/4"

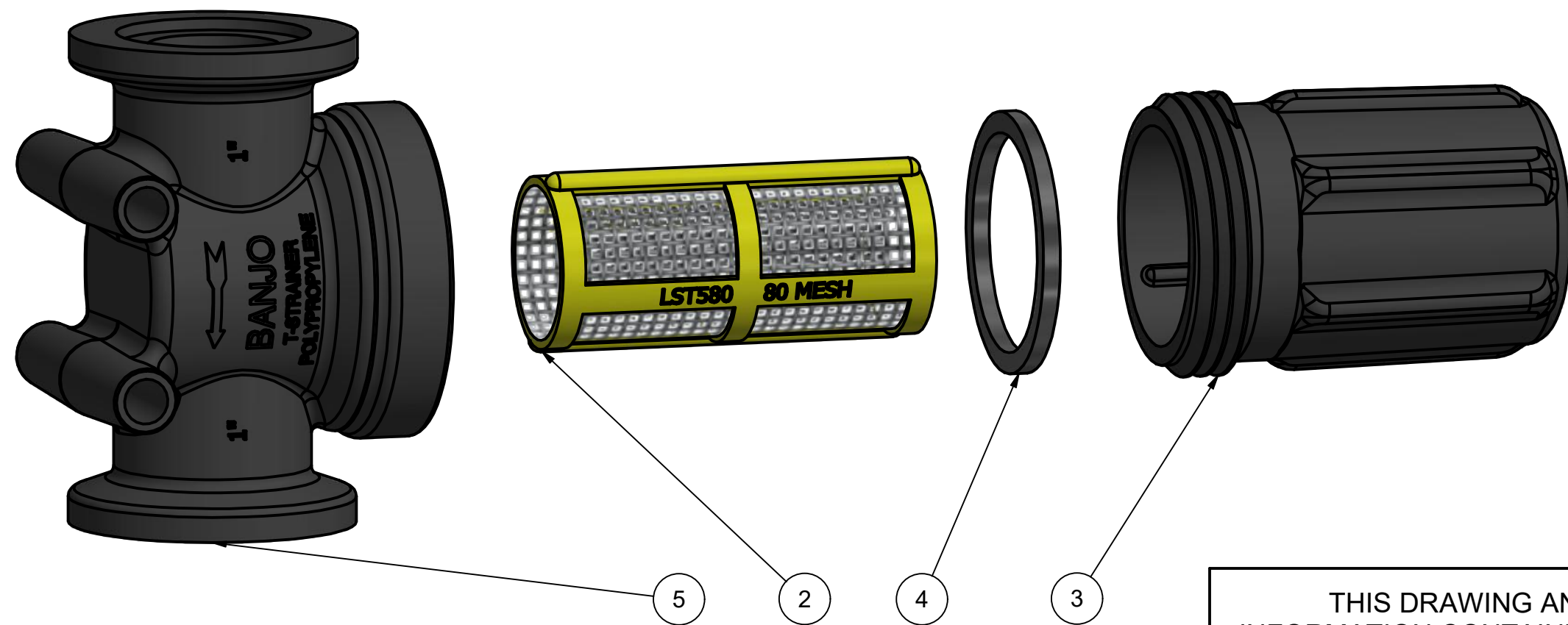
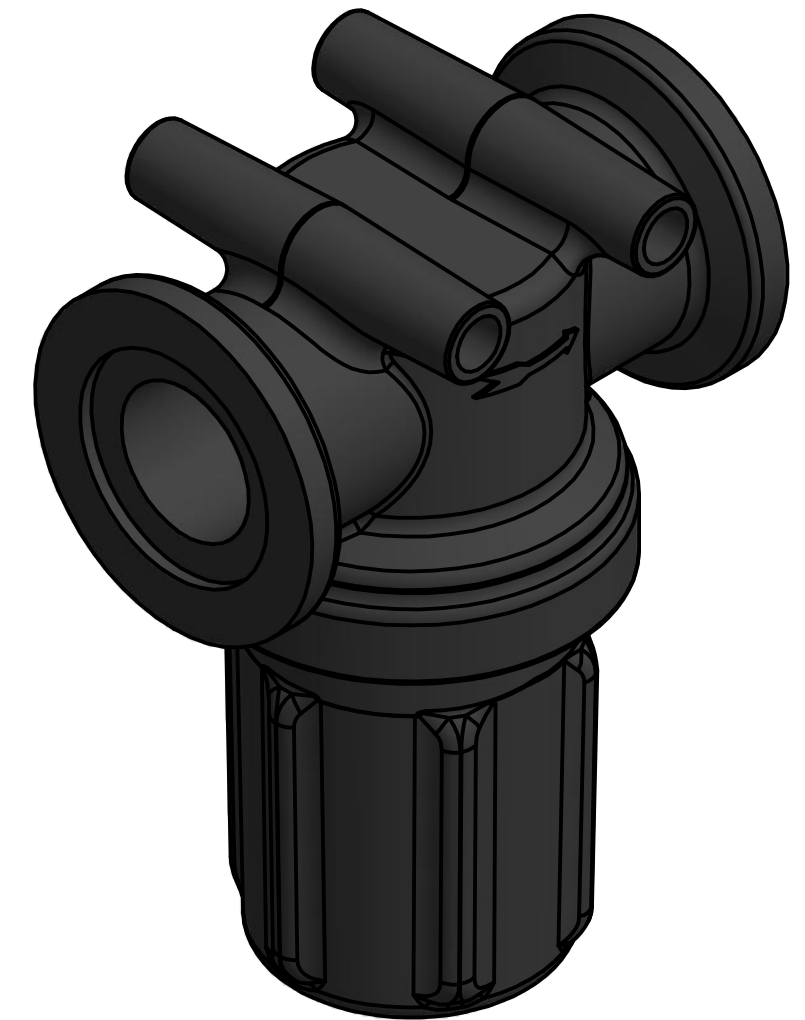
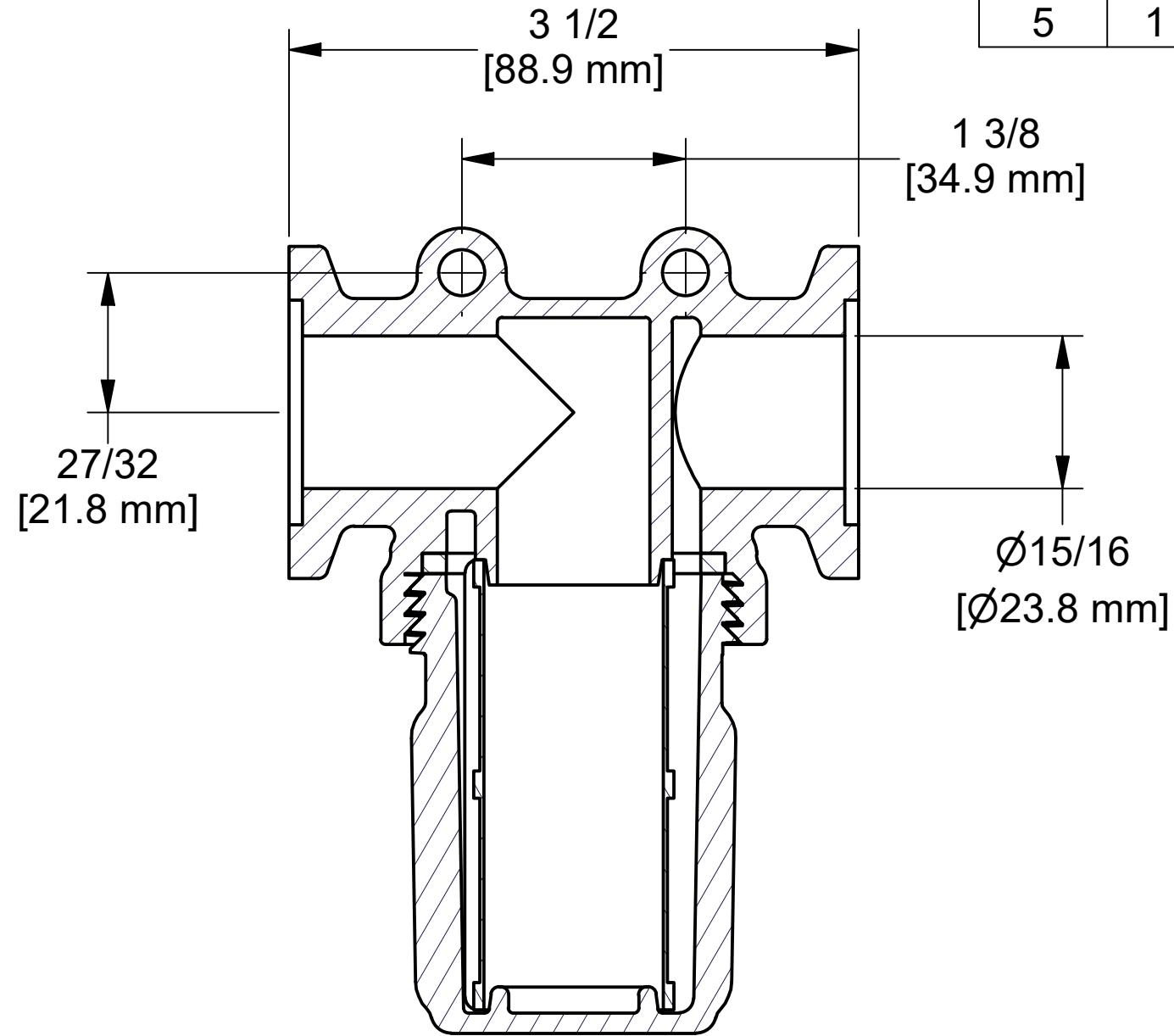
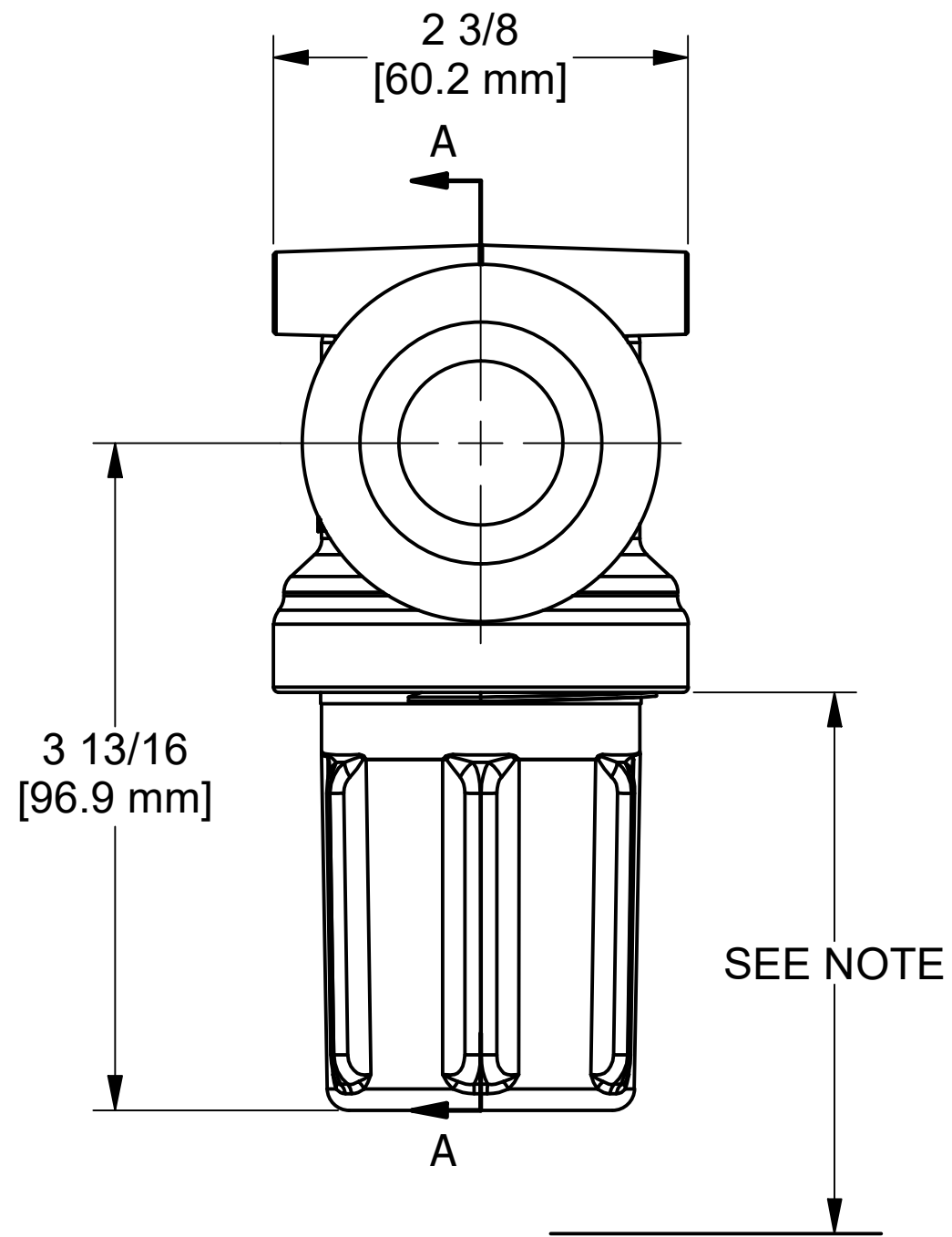

THIS DRAWING AND ALL INFORMATION CONTAINED THEREON ARE THE EXCLUSIVE PROPERTY OF BANJO CORPORATION.

UNLESS SPECIFICALLY NOTED, THIS DRAWING AND ITEMS SHOWN ON THIS DRAWING ARE SUBJECT TO CHANGE AT ANY TIME.



**BANJO CORPORATION**

BANJO CORPORATION  
150 BANJO DRIVE, CRAWFORDSVILLE, IN 47933  
WEB SITE: WWW.BANJOCORP.COM  
E-MAIL: BANJOSALES@IDEXCORP.COM

DESCRIPTION  
**1" MNFLD T-STRAINER - 80 MESH**

PART NUMBER  
**MLSTM100-80**