

NOTE:
ADDITIONAL CLEARANCE REQ'D
FOR SCREEN REMOVAL: 2 3/4"

| Parts List | | | |
|------------|-----|-------------|-------------------------------|
| ITEM | QTY | PART NUMBER | DESCRIPTION |
| 1 | 1 | LST1100D | 100 PSI DECAL (N/S) |
| 2 | 1 | LSTM050BC | MINI T-STRAINER CLEAR BOWL |
| 3 | 1 | LSTM050G | MINI T-STRAINER GASKET |
| 4 | 1 | MLSTM100H | 1" MNFLD MINI T-STRAINER HEAD |

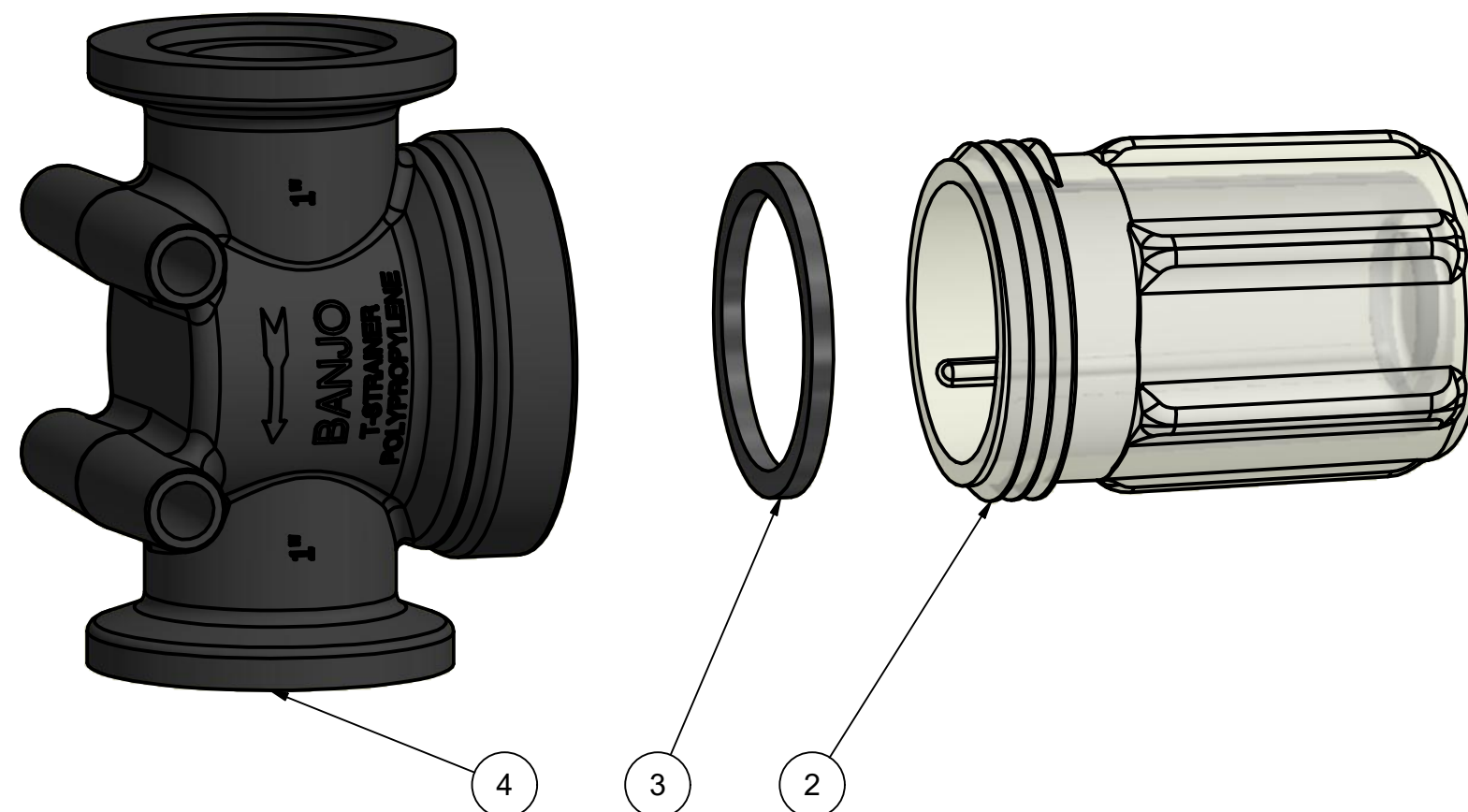
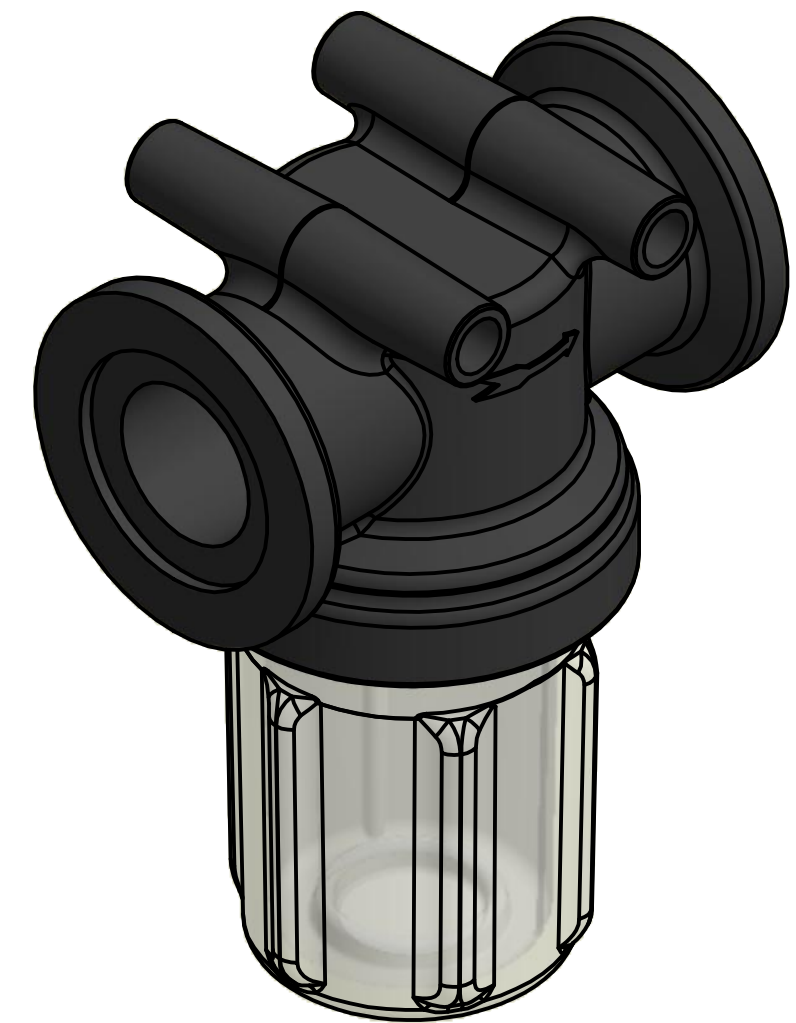
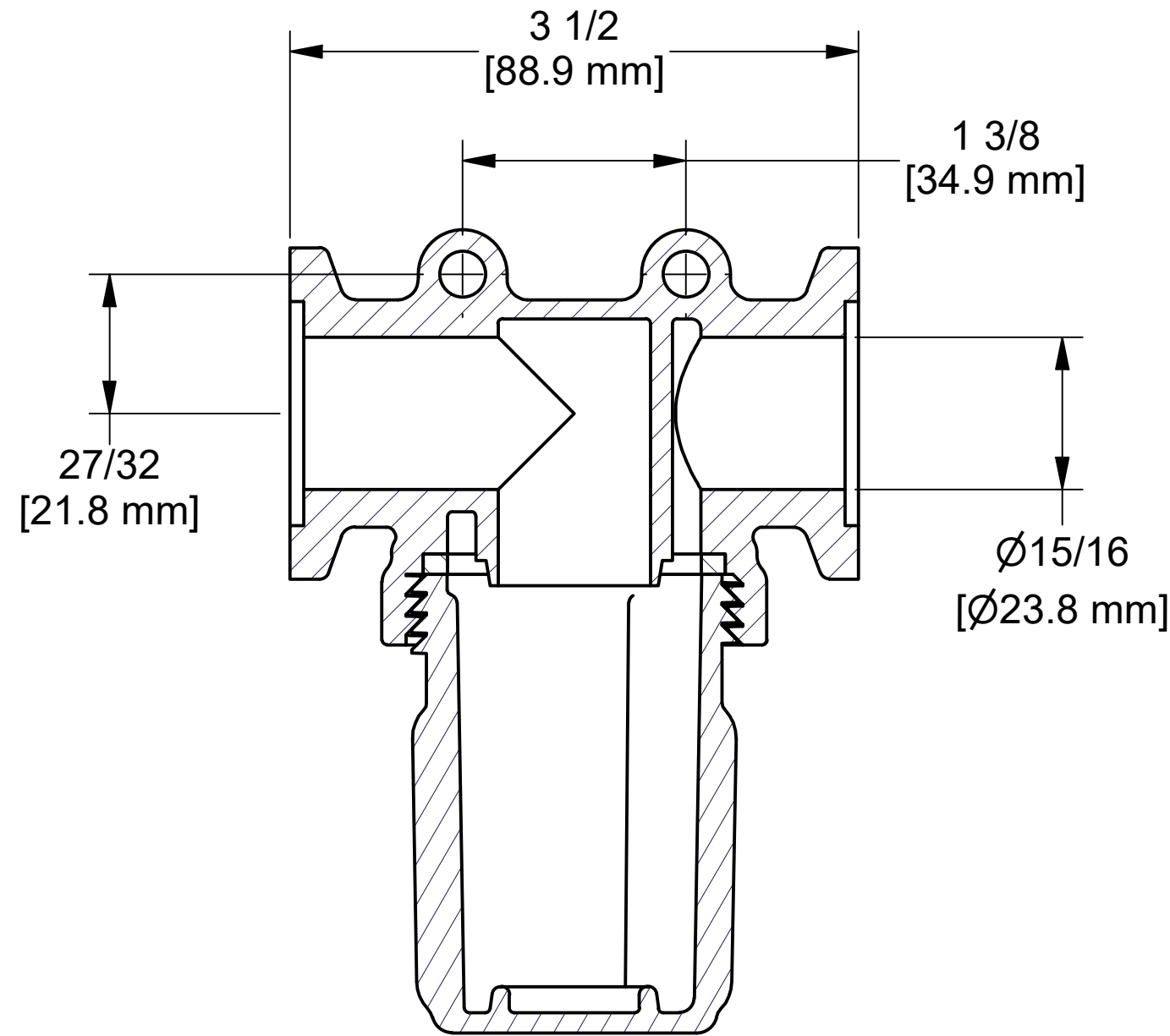
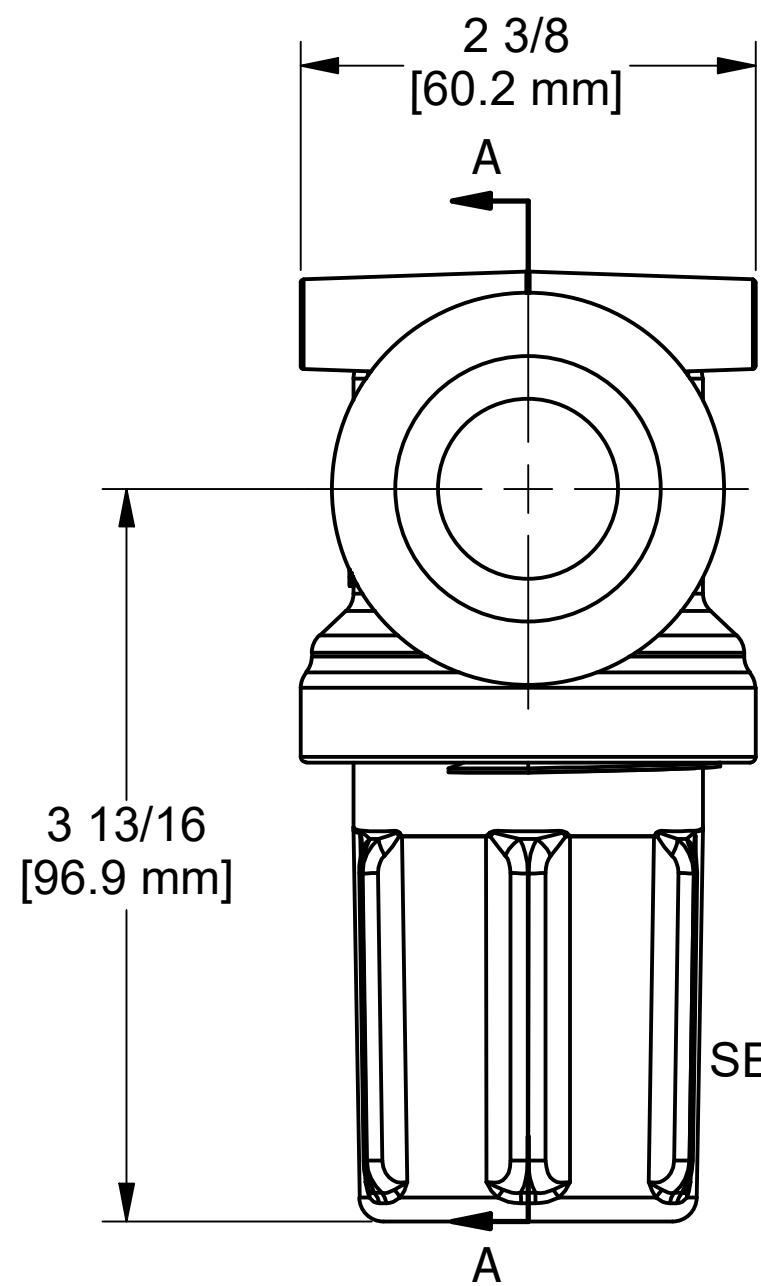

THIS DRAWING AND ALL INFORMATION CONTAINED THEREON ARE THE EXCLUSIVE PROPERTY OF BANJO CORPORATION.

UNLESS SPECIFICALLY NOTED, THIS DRAWING AND ITEMS SHOWN ON THIS DRAWING ARE SUBJECT TO CHANGE AT ANY TIME.

BANJO CORPORATION

BANJO CORPORATION
150 BANJO DRIVE, CRAWFORDSVILLE, IN 47933
WEB SITE: WWW.BANJOCORP.COM
E-MAIL: BANJOSALES@IDEXCORP.COM

DESCRIPTION
1" MNFLD T-Strainer, CLEAR BOWL - NO SCREEN

PART NUMBER
MLSTM100HBC