

PARTS LIST			
ITEM	QTY	PART NUMBER	DESCRIPTION
1	1	V10020A	10-32 X 1 1/4" SMS
2	1	V10060	THRUST BEARING
3	4	V10117	5/16 - 18 X 3 1/2" HHCS
4	4	V10118	5/16" LOCKWASHER
5	4	V10119	5/16" HEX NUT
6	1	V10151A	STEM W/O INSERT
7	1	V10153A	HANDLE
8	1	V10155	1" Valve Ball
9	1	V10159	STEM BUSHING
10	1	V10163	#113 O-RING, FKM
11	1	V10254	1" VALVE BODY
12	2	V10258A	3" FP Ball Seat
13	2	V10264	#36 O'RING
14	2	V10278	1" Manifold Endplate

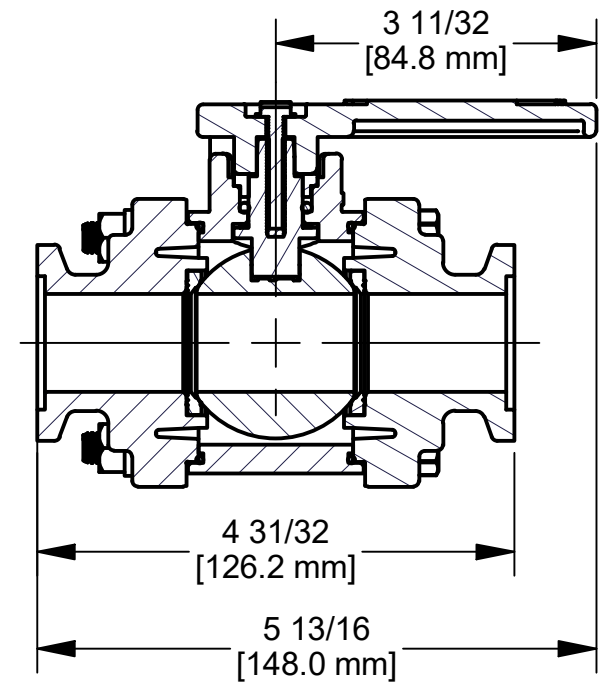
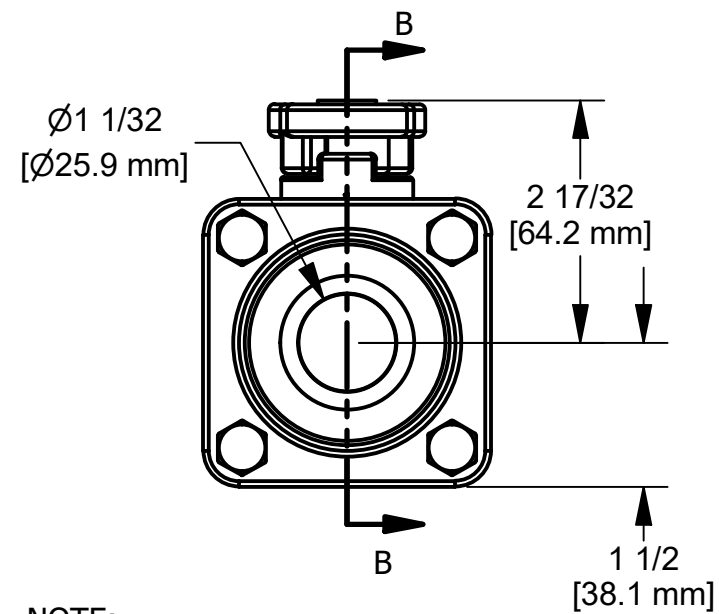
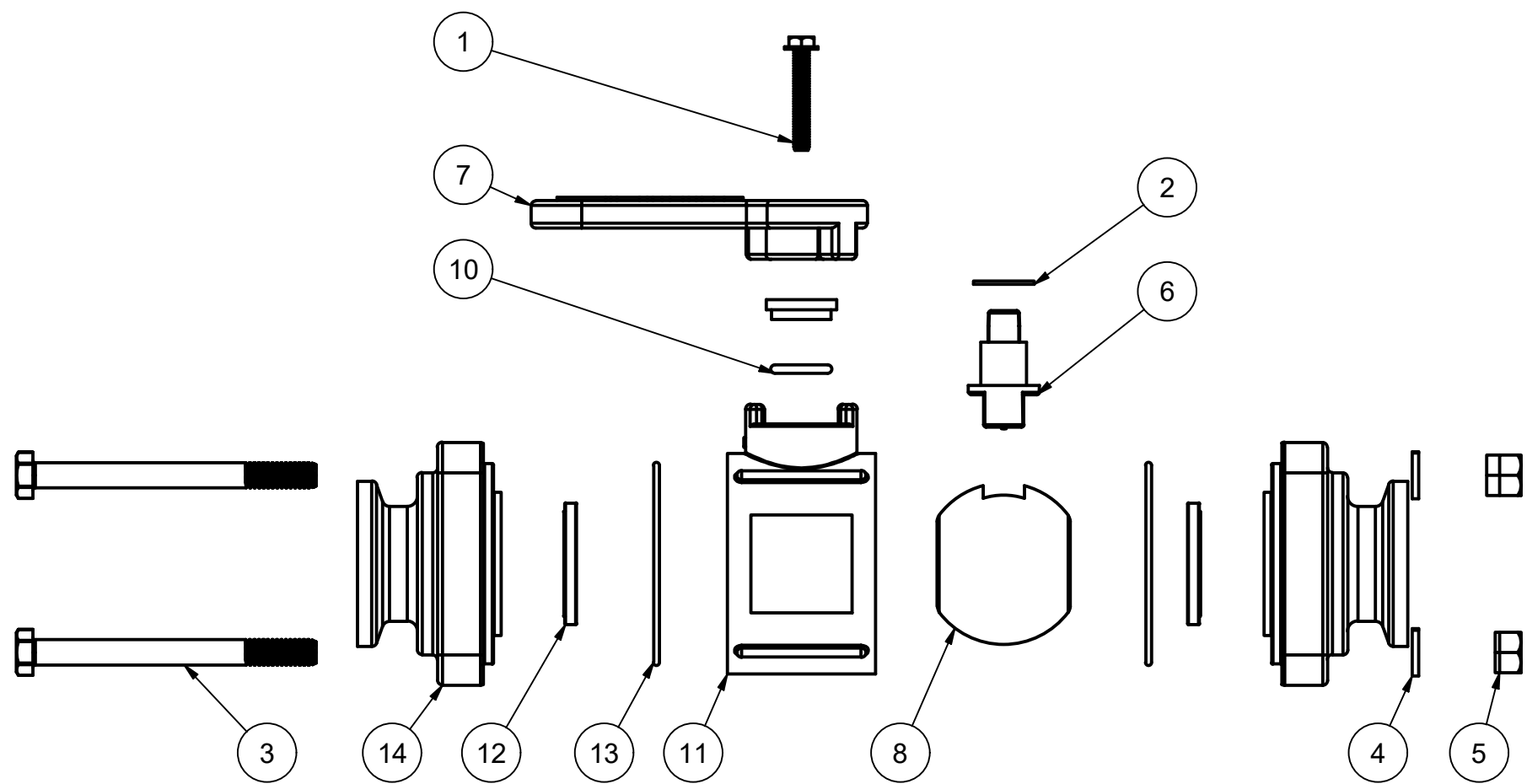

SECTION B-B  
SCALE 1/2

NOTE:  
MATL: 40 % GF PP, Black  
ALL TEXT RAISED ON PART

THIS DRAWING AND ALL INFORMATION CONTAINED THEREON ARE THE EXCLUSIVE PROPERTY OF BANJO CORPORATION.  
UNLESS SPECIFICALLY NOTED, THIS DRAWING AND ITEMS SHOWN ON THIS DRAWING ARE SUBJECT TO CHANGE AT ANY TIME.

**BANJO CORPORATION**  
 150 BANJO DRIVE, CRAWFORDSVILLE, IN 47933  
 WEB SITE: WWW.BANJOCORP.COM  
 E-MAIL: BANJOSALES@IDEXCORP.COM

DESCRIPTION  
**1" FULL PORT w/ C-FLANGE**

PART NUMBER  
**MV100CF**