

SECTION A-A
SCALE 1 : 1

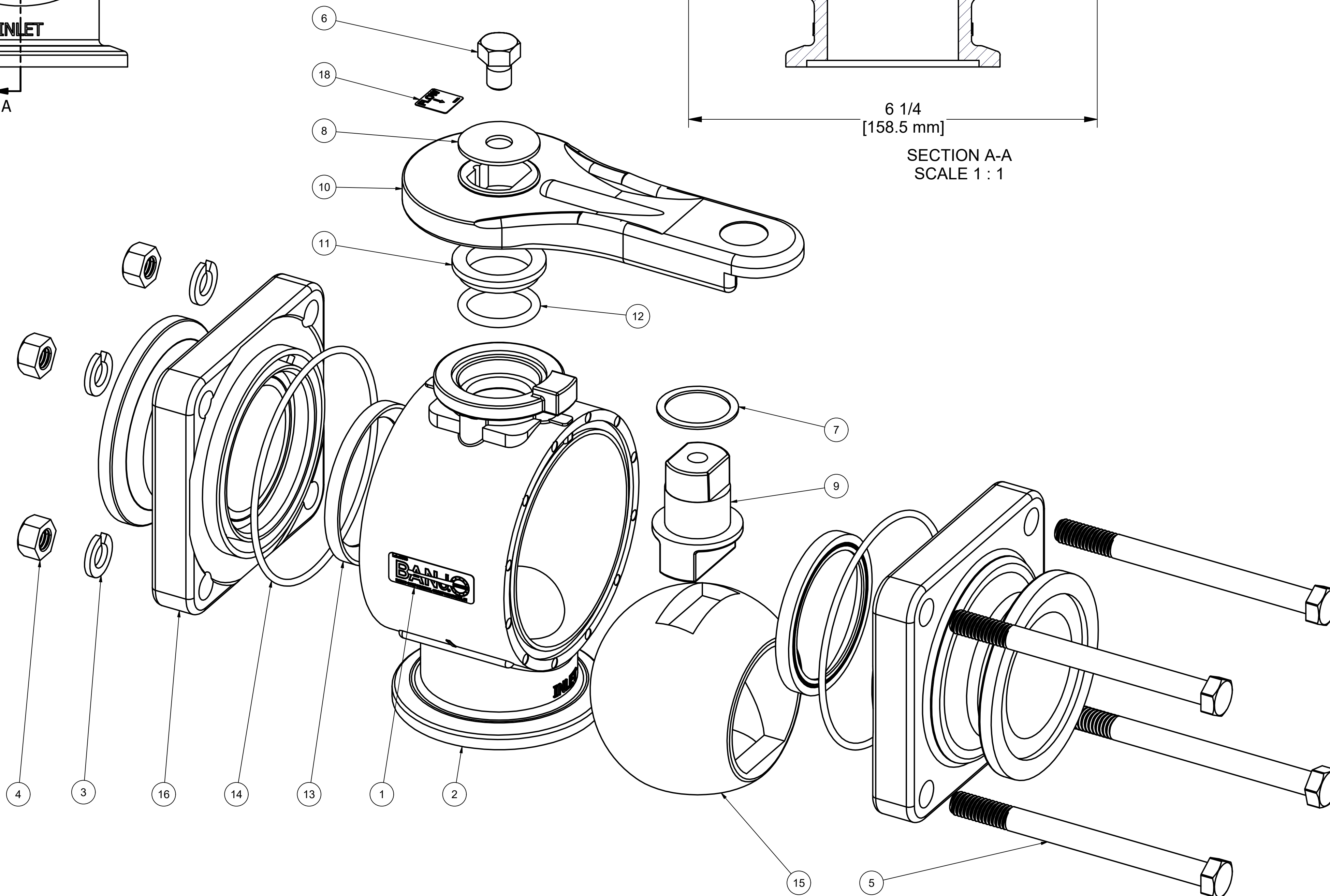

Parts List			
ITEM	QTY	PART NUMBER	DESCRIPTION
1	1	050DECAL	BANJO LOGO DECAL
2	1	MV25354B	2" FP MNFLD BL VALVE BODY
3	4	V20018	3/8" LOCKWASHER
4	4	V20019	3/8" HEX NUT
5	4	V25017	3/8-16 X 4 1/2" HHCS
6	1	V25020	3/8" HANDLE BOLT
7	1	V25060	VALVE STEM THRUST BEARING
8	1	V25121	3/8" FENDER WASHER
9	1	V25151B	STEM 2"FP & 3"FP, MACHINED
10	1	V25153SB	2" FP HANDLE
11	1	V25160	STEM BUSHING
12	1	V25163	#214 FKM O'RING
13	2	V25258	3" FP BALL SEAT
14	2	V25264	O-RING, ID: 3.575", CS: 0.103, FKM
15	1	V25355B	2" FP BL 3-WAY BALL, TUMBLED
16	2	V25378	2" FP 3-WAY MNFLD END PLATE, MACHINED
17	1	VL1001	150 PSI DECAL (N/S)
18	1	VL200BL	BOTTOM LOAD FLOW LABEL



THIS DRAWING AND ALL INFORMATION CONTAINED THEREON ARE THE EXCLUSIVE PROPERTY OF BANJO CORPORATION.

UNLESS SPECIFICALLY NOTED, THIS DRAWING AND ITEMS SHOWN ON THIS DRAWING ARE SUBJECT TO CHANGE AT ANY TIME.

BANJO CORPORATION
150 BANJO DRIVE, CRAWFORDSVILLE, IN 47933
WEB SITE: WWW.BANJO.CORP.COM
E-MAIL: BANJOSALES@DEXCORP.COM

DESCRIPTION
2" Bottom Load Valve Assy W/ Short Handle

PART NUMBER
MV220BLSH