

8 7 6 5 4 3 2 1

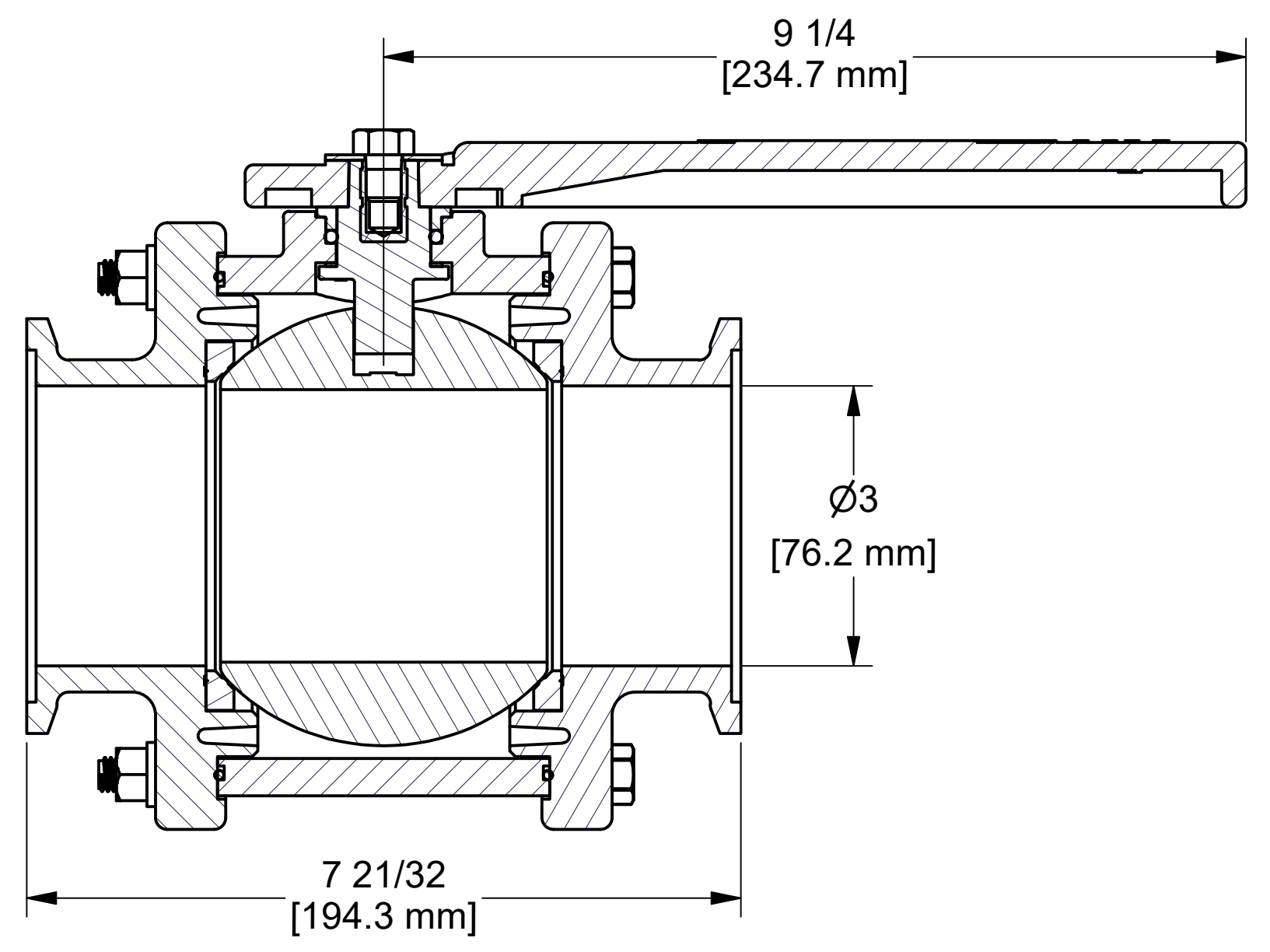

PARTS LIST			
ITEM	QTY	PART NUMBER	DESCRIPTION
1	6	V20018	3/8" LOCKWASHER
2	6	V20019	3/8" HEX NUT
3	6	V25018	3/8-16 X 5 1/2" HHCS
4	1	V25020	3/8" HANDLE BOLT
5	1	V25060	VALVE STEM THRUST BEARING
6	1	V25121	3/8" FENDER WASHER
7	1	V25153	2" FP HANDLE
8	1	V25160	Stem Bushing
9	1	V25163	#214 FKM O'RING
10	1	V30151	STEM 3"FP STUBBY, MACHINED
11	1	V35254A	3" FP VALVE BODY
12	1	V35255A	3" FULL PORT BALL, TUMBLED
13	2	V35258A	3" FP BALL SEAT
14	2	V35265	3" FP BODY O-RING FKM
15	2	V35278A	3" FP MANIFOLD ENDPLATE, MACHINED
16	1	VL1016	200 PSI DECAL (N/S)

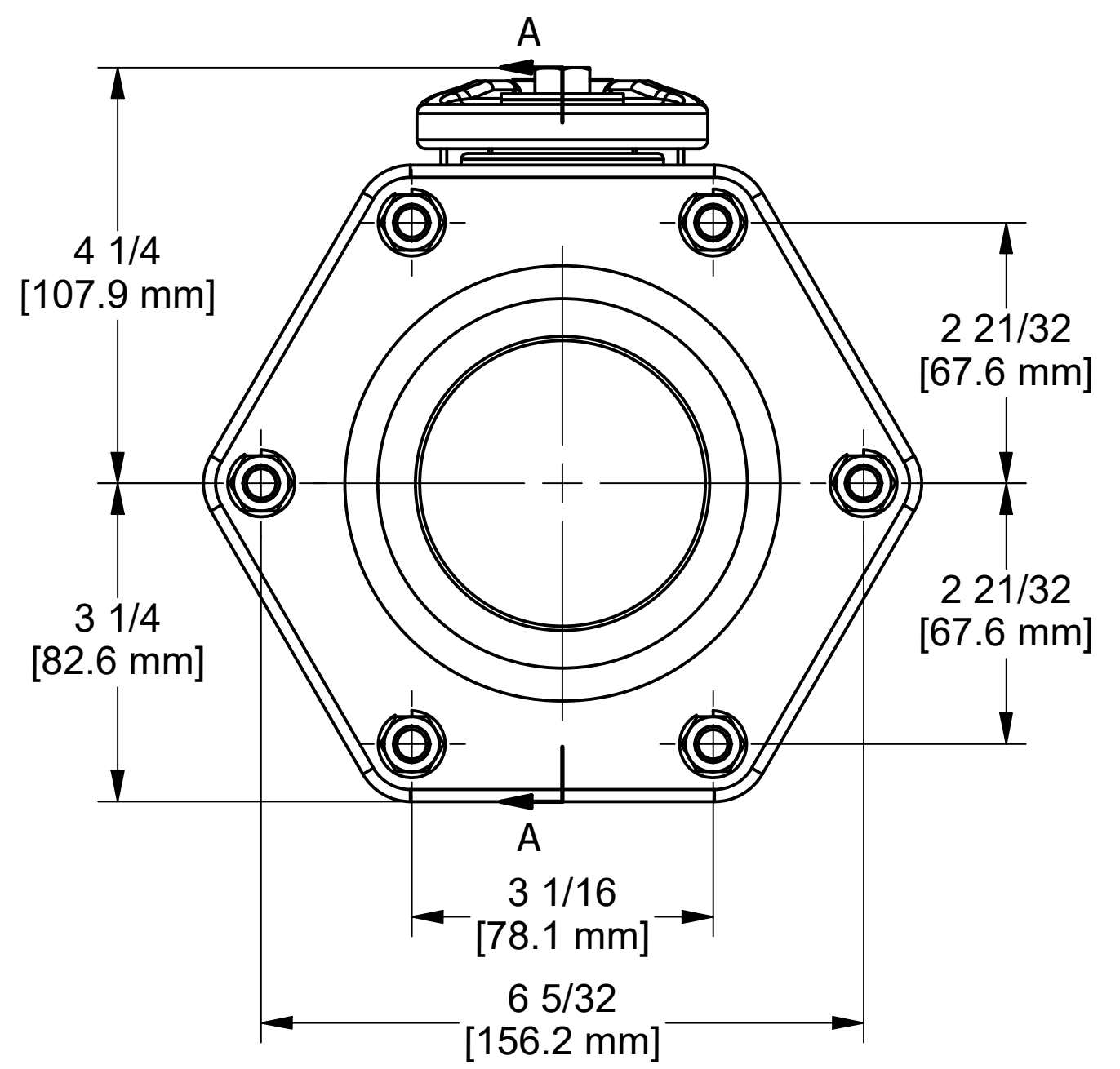
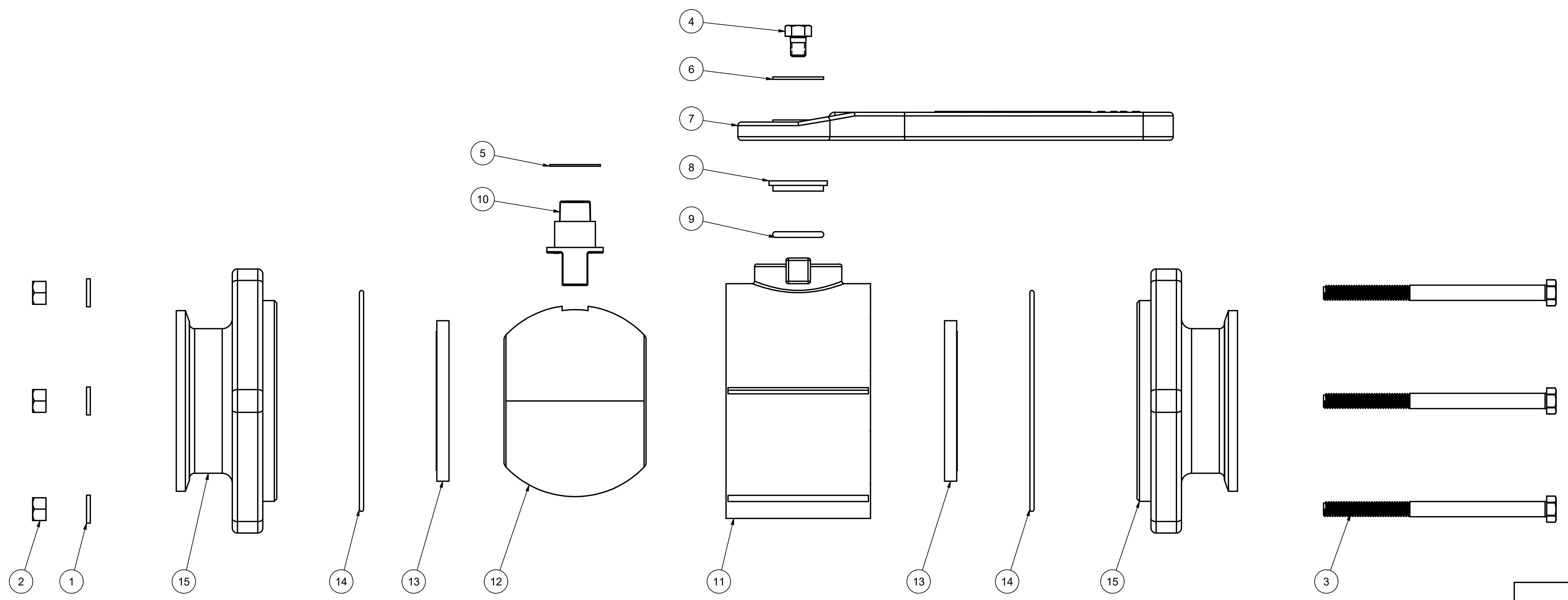

THIS DRAWING AND ALL INFORMATION CONTAINED THEREON ARE THE EXCLUSIVE PROPERTY OF BANJO CORPORATION.
UNLESS SPECIFICALLY NOTED, THIS DRAWING AND ITEMS SHOWN ON THIS DRAWING ARE SUBJECT TO CHANGE AT ANY TIME.

BANJO CORPORATION
150 BANJO DRIVE, CRAWFORDSVILLE, IN 47933
WEB SITE: WWW.BANJO.CORP.COM
E-MAIL: BANJOSALES@IDEXCORP.COM

DESCRIPTION
3" FLANGED MNFLD VALVE

PART NUMBER
MV301CF

8 7 6 5 4 3 2 1