

SECTION B-B
SCALE 5 / 6

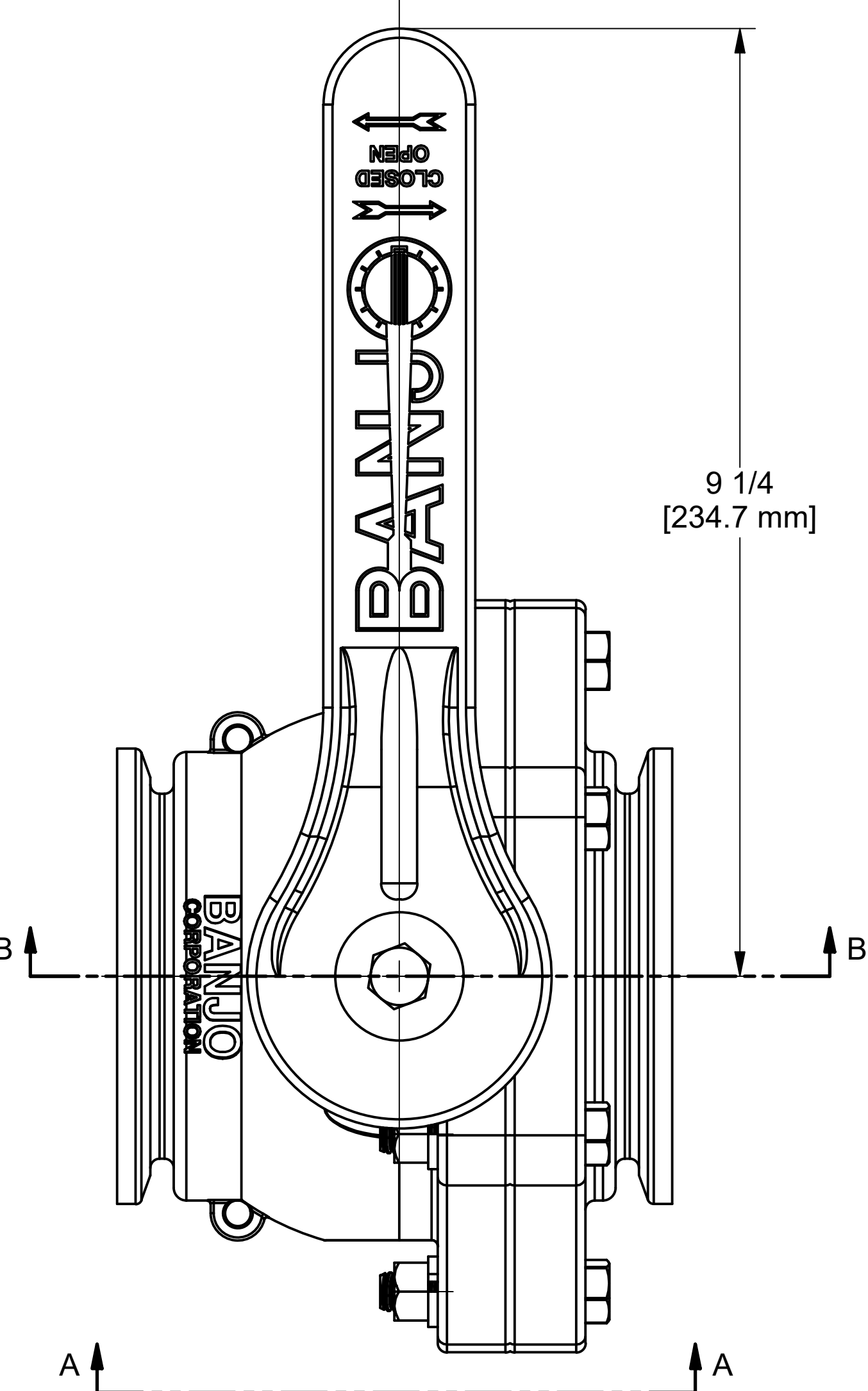

VIEW A-A
SCALE 5 / 6

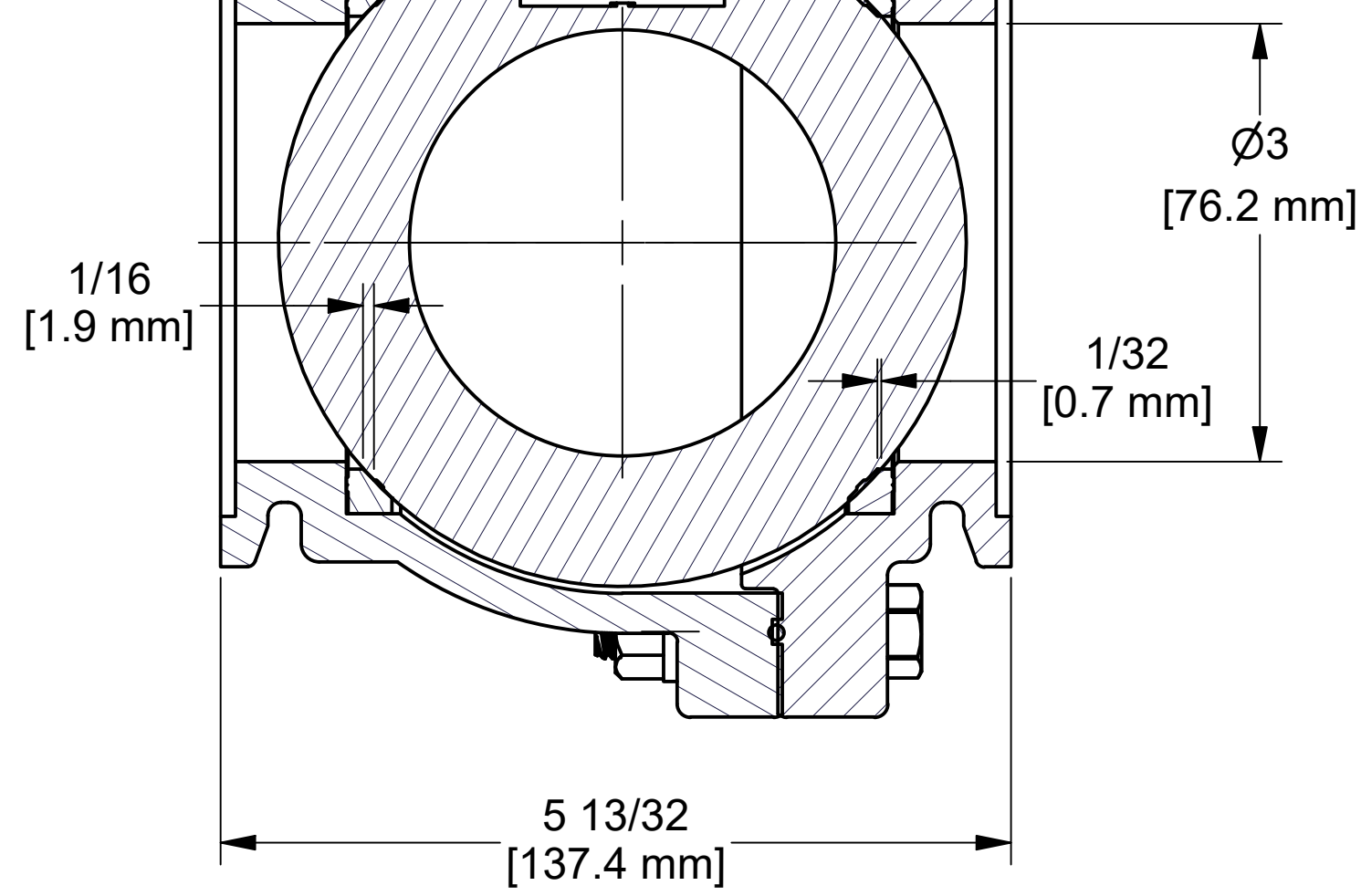
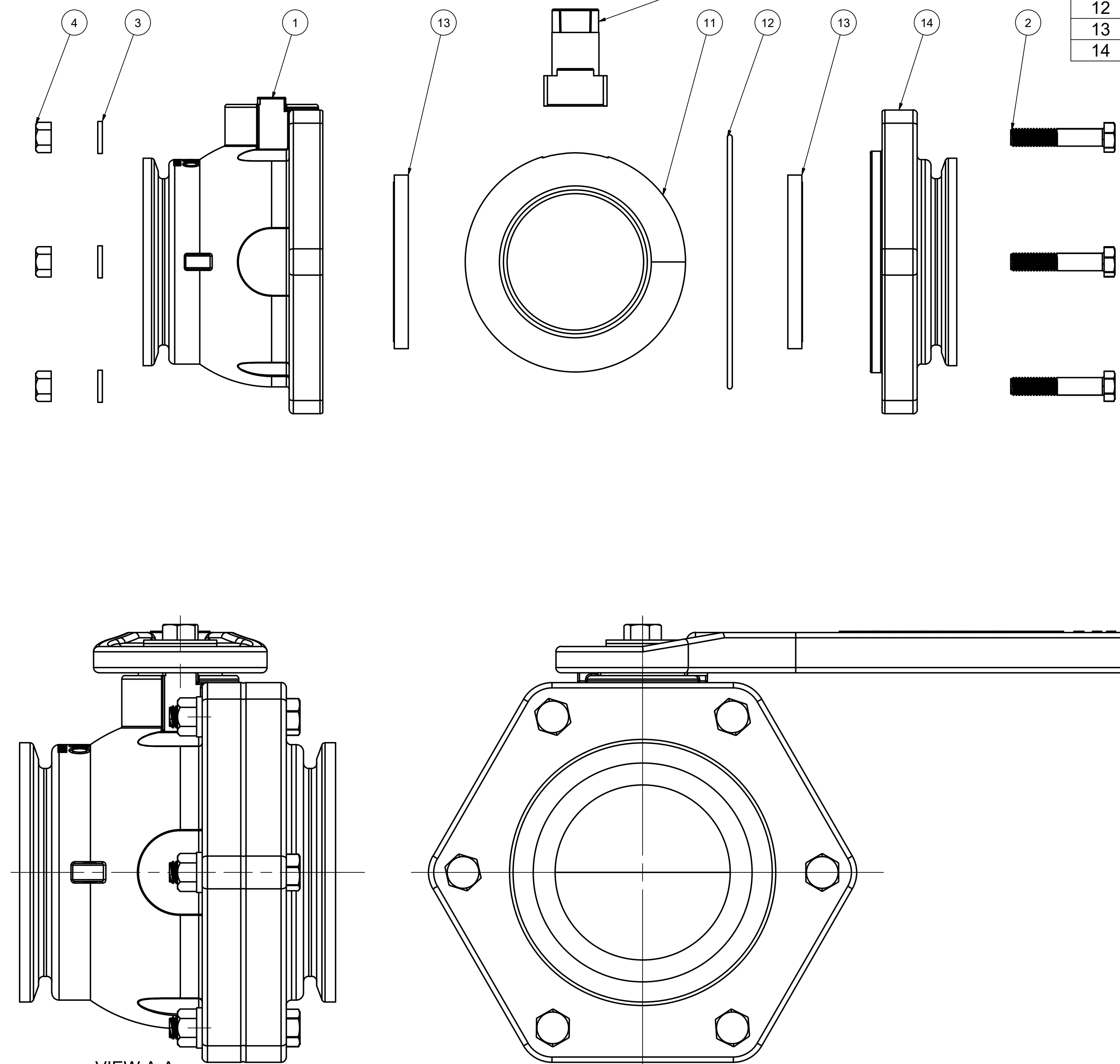

PARTS LIST

ITEM	QTY	PART NUMBER	DESCRIPTION
1	1	MVS35254	3"FP MANIFOLD STUBBY BODY, MACHINED
2	6	V20010SS	3/8-16 X 2" HHCS
3	6	V20018	3/8" LOCKWASHER
4	6	V20019	3/8" HEX NUT
5	1	V25020	3/8" Handle Bolt
6	1	V25121	3/8" Fender Washer
7	1	V25153	2" FP Handle
8	1	V25160	Stem Bushing
9	1	V25163	AS568A -214 O-RING, FKM, BROWN
10	1	V30151B	STEM 3" & 4" STUBBY, MACHINED
11	1	V35255A	3" FULL PORT BALL, TUMBLER
12	1	V35265	AS568A -160 O-RING, FKM, BROWN
13	2	VS35258	3" FP Stubby Valve Seat
14	1	VS35278	3" FP STUBBY MNFLD FLANGE EP, MACHINED

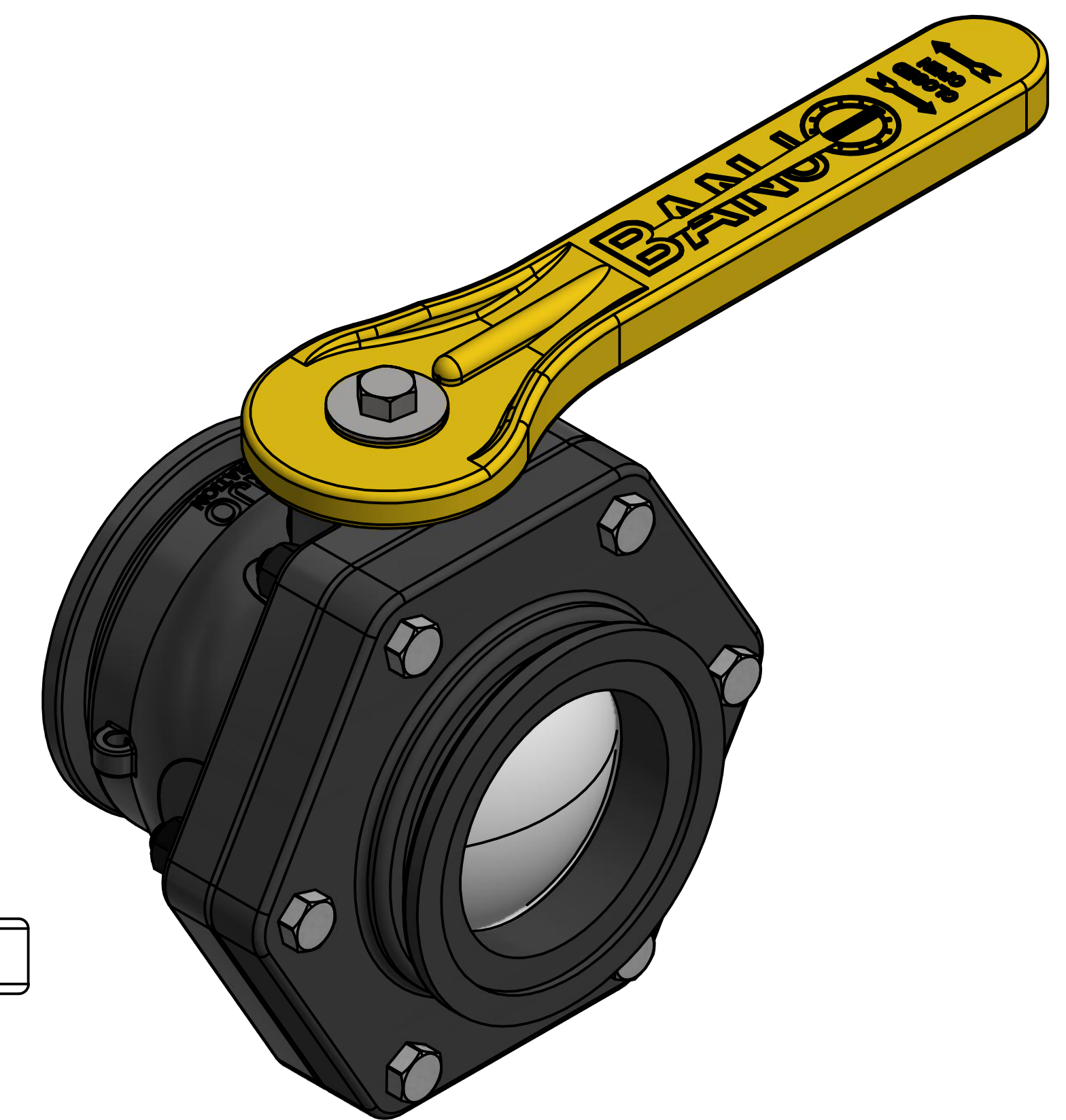

THIS DRAWING AND ALL INFORMATION CONTAINED THEREON ARE THE EXCLUSIVE PROPERTY OF BANJO CORPORATION.

UNLESS SPECIFICALLY NOTED, THIS DRAWING AND ITEMS SHOWN ON THIS DRAWING ARE SUBJECT TO CHANGE AT ANY TIME.

BANJO CORPORATION
 150 BANJO DRIVE, CRAWFORDSVILLE, IN 47933
 WEB SITE: WWW.BANJO.CORP.COM
 E-MAIL: BANJOSALES@DEXCORP.COM

DESCRIPTION
3" FP MANIFOLD STUBBY VALVE

PART NUMBER
MVS300CFPP