

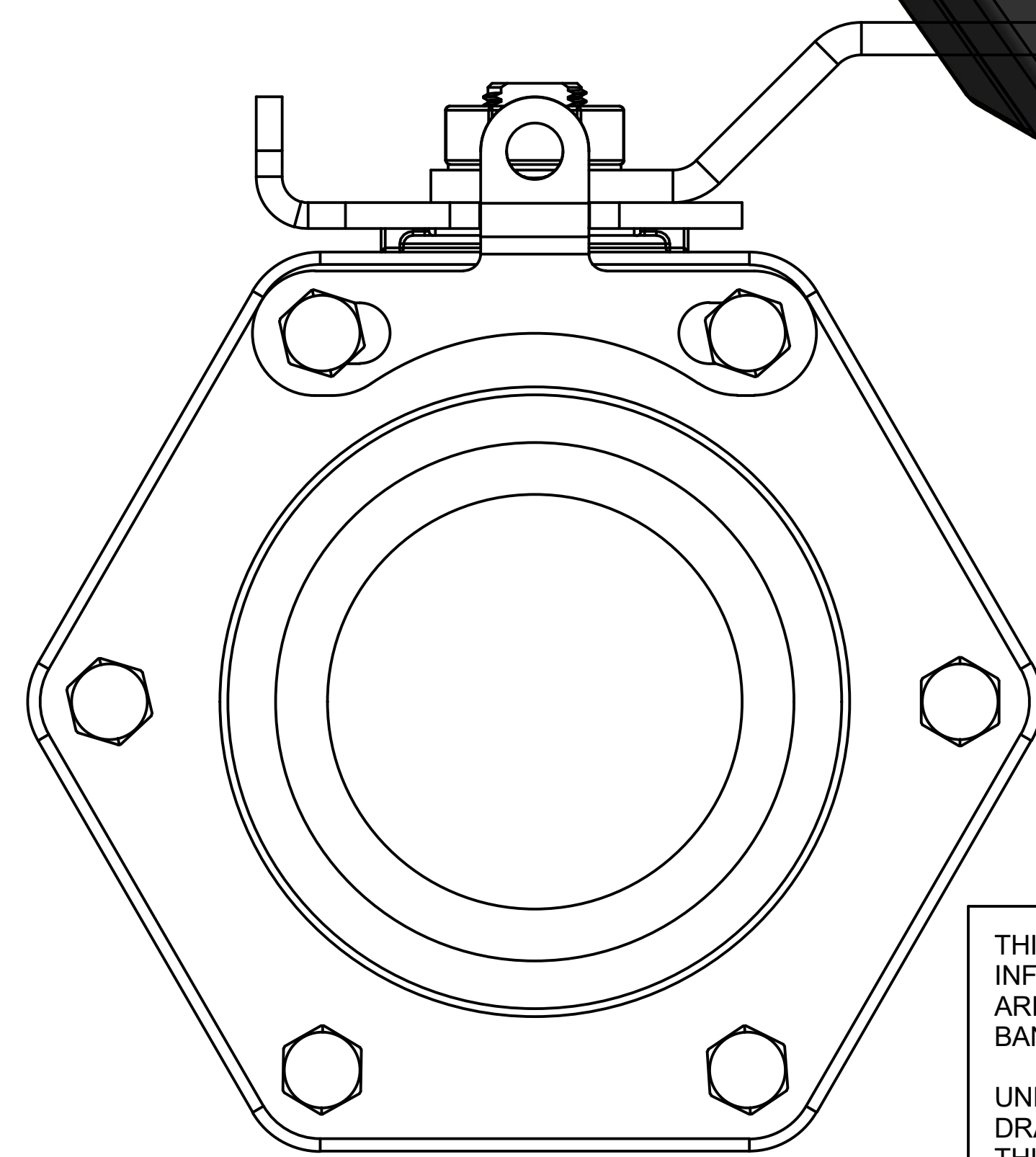

Parts List			
ITEM	QTY	PART NUMBER	DESCRIPTION
1	1	MVS35254	3" FP Stubby Manifold Body
2	6	V20010SS	3/8-16 X 2" HHCS
3	6	V20018	3/8" LOCKWASHER
4	6	V20019	3/8" HEX NUT
5	1	V25160	Stem Bushing
6	1	V25163	#214 FKM O'RING
7	1	V35255ASS	3" FP SS Hollow Ball
8	1	V35265	3" FP body O-ring FKM
9	1	VS30101SS	Handle Stop Plate
10	1	VS30102SS	3" Std Port Stubby Valve handle Lock
11	1	VS30151SS	3" SS Stubby Valve Stem
12	1	VS30153SS	3" Valve handle, SS
13	2	VS35258	3" FP Stubby Valve Seat
14	1	VS35278	3" FP Stubby Manifold Endplate
15	1	VSS30020	3/4"-16 SS Jam Nut
23	1	V25060	VALVE STEM THRUST BEARING
24	1	VS30021	5/8" Internal Tooth Lock Washer

REVISION HISTORY				
ZONE	REV	DESCRIPTION	DATE	APPROVED
	A	Added V25060	06/08/11	ALR
	B	Added VS30021	07/21/2011	ALR

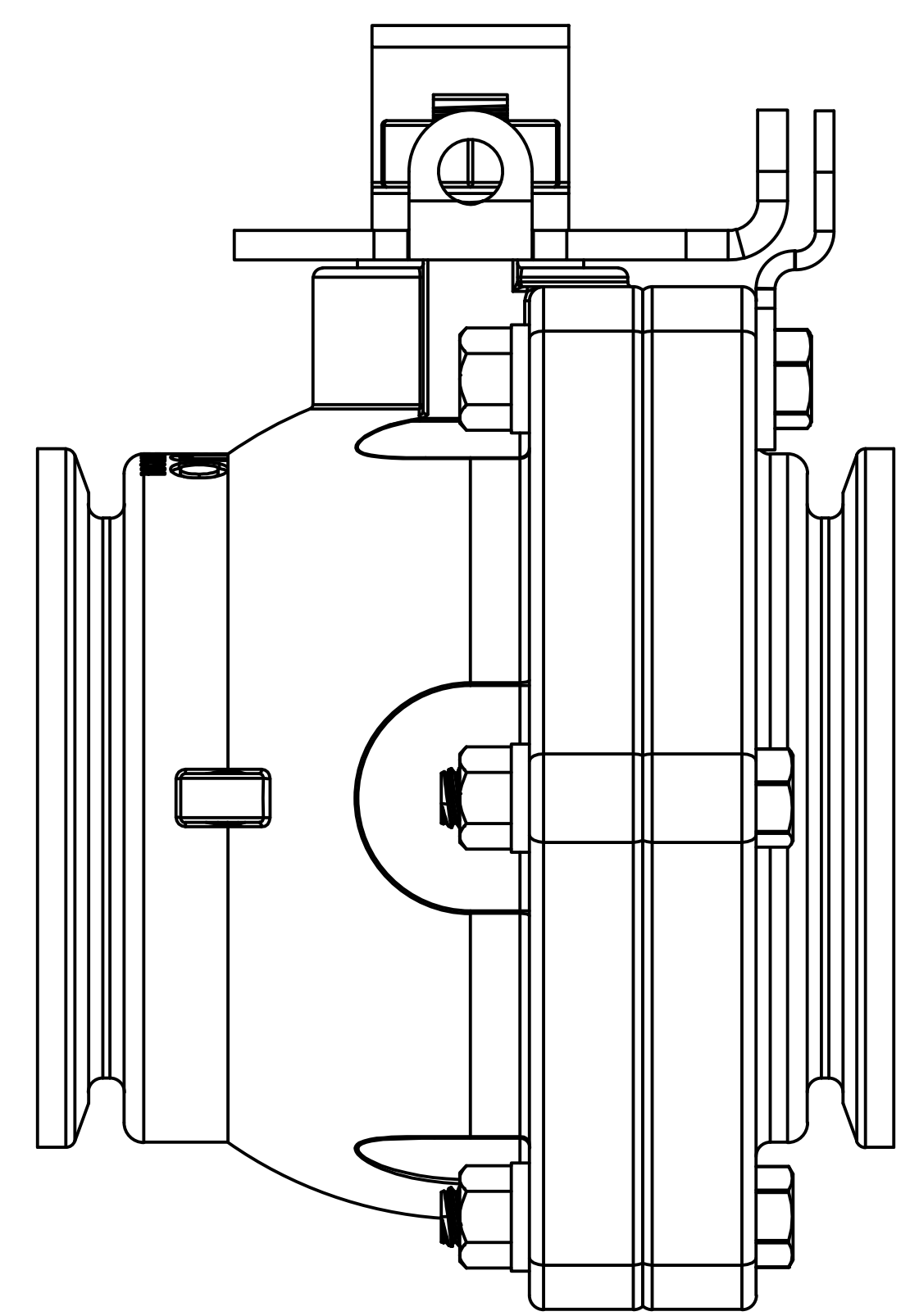
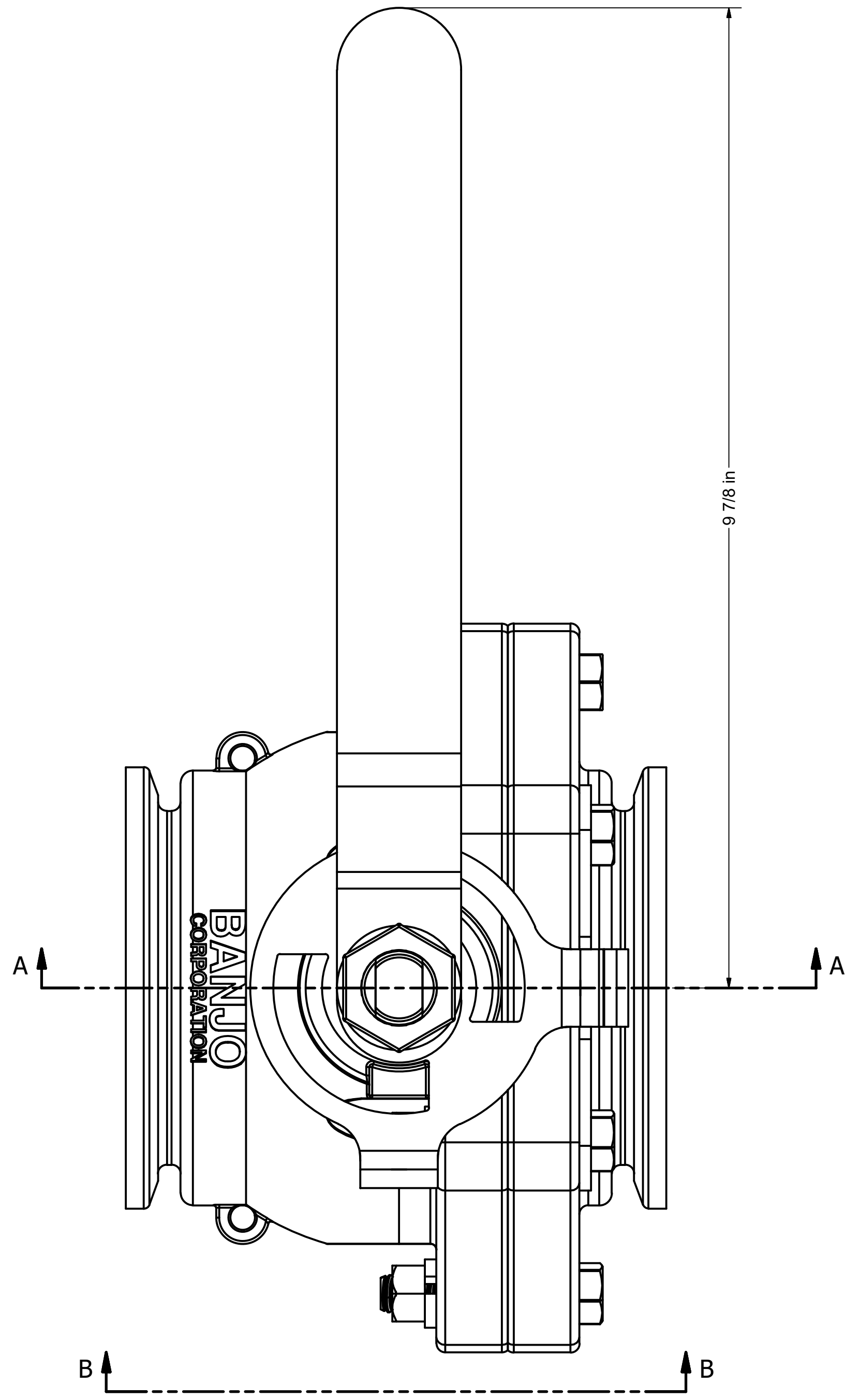
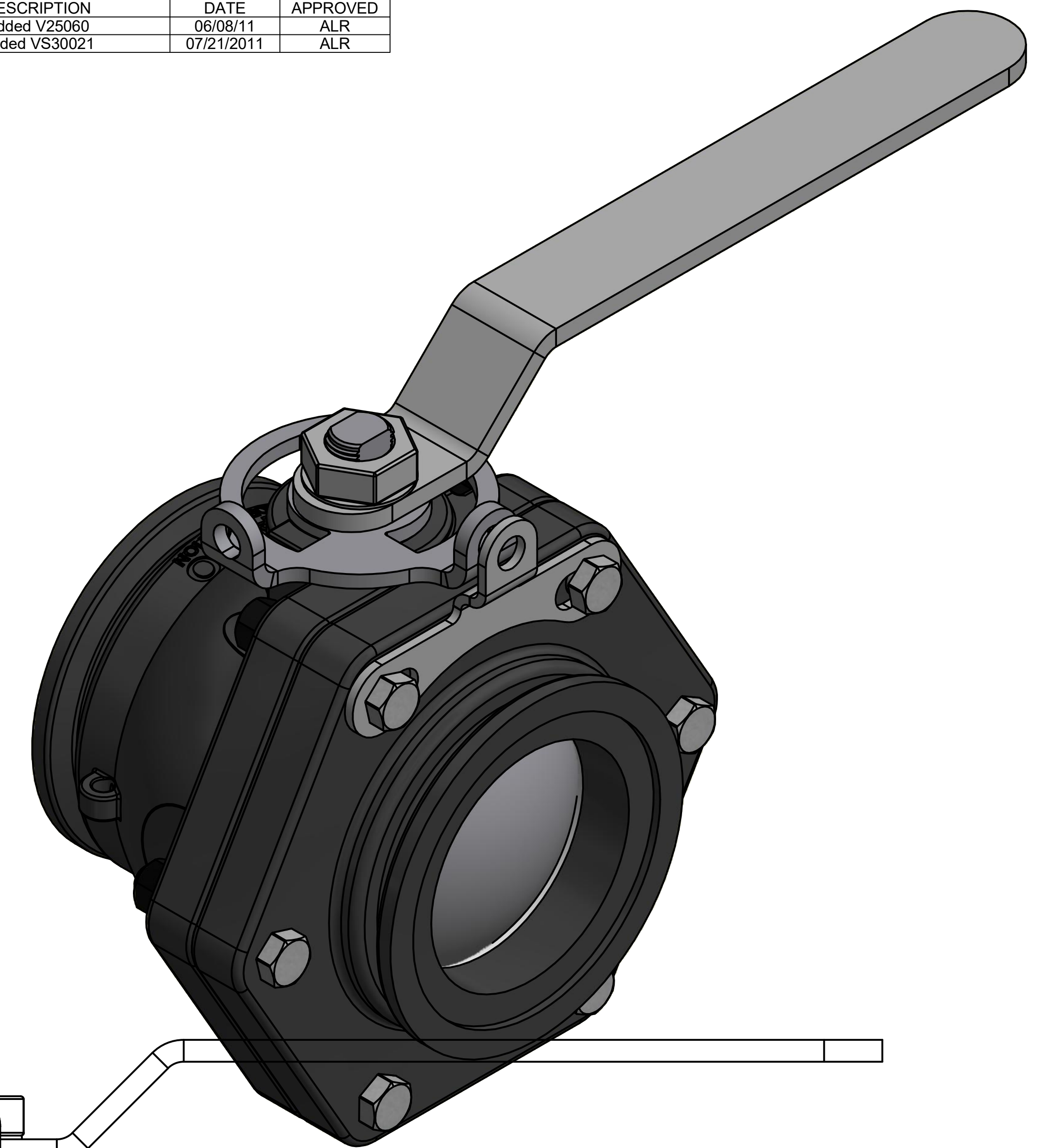
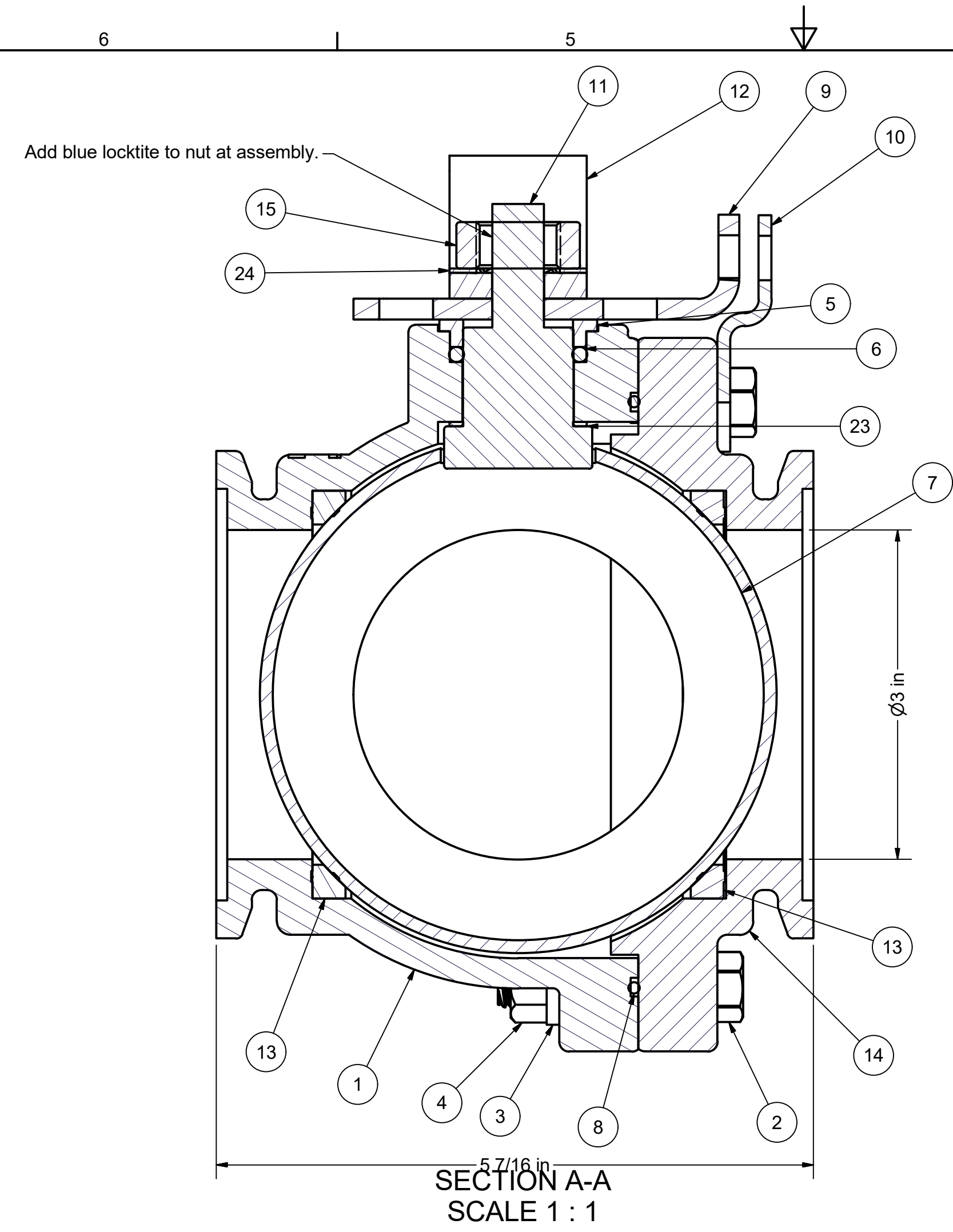

THIS DRAWING AND ALL INFORMATION CONTAINED THEREON ARE THE EXCLUSIVE PROPERTY OF BANJO CORPORATION.

UNLESS SPECIFICALLY NOTED, THIS DRAWING AND ITEMS SHOWN ON THIS DRAWING ARE SUBJECT TO CHANGE AT ANY TIME.



**BANJO CORPORATION**  
 150 BANJO DRIVE, CRAWFORDSVILLE, IN 47933  
 WEB SITE: WWW.BANJOCORP.COM  
 E-MAIL: SALES1@BANJOCORP.COM

DESCRIPTION  
**3" FP Stubby Manifold Flange Valve SS Ball, Stem, Handle**

PART NUMBER  
**MVS300HSFP**