

SECTION A-A
SCALE 1/2

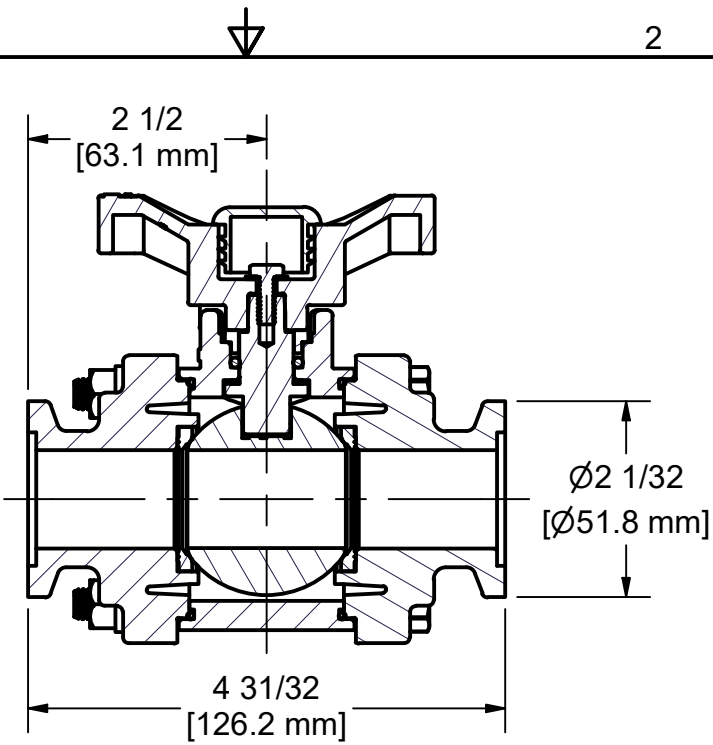

PARTS LIST			
ITEM	QTY	PART NUMBER	DESCRIPTION
1	1	SW10	#10 WASHER
2	1	V07020	#10-24x0.50 HHCS 18-8SS
3	1	V10060	THRUST BEARING
4	4	V10117	5/16 - 18 X 3 1/2" HHCS
5	4	V10118	5/16" LOCKWASHER
6	4	V10119	5/16"-18 SS NUT
7	1	V10151	1" VALVE STEM W/ INSERT
8	1	V10155	VALVE BALL 1" FP, TUMBLED
9	1	V10159	UPPER-LOWER STEM BUSHING, PTFE
10	1	V10163	AS568A -113 O-RING, FKM, BROWN
11	1	V10254	1" VALVE BODY
12	2	V10258A	1" BALL VALVE SEAT, STYLE A
13	2	V10264	AS568A -036 O-RING, FKM, BROWN
14	2	V10278	1" MANIFOLD ENDPLATE, MACHINED
15	1	V10353T	BOTTOM LOAD T-HANDLE
16	1	V20353C	1 1/8" CAPPLUG

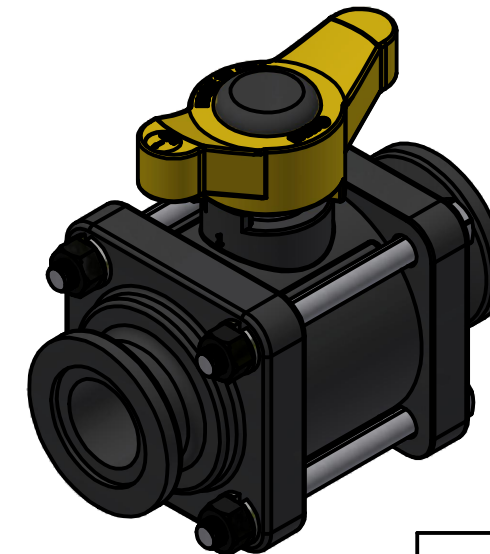
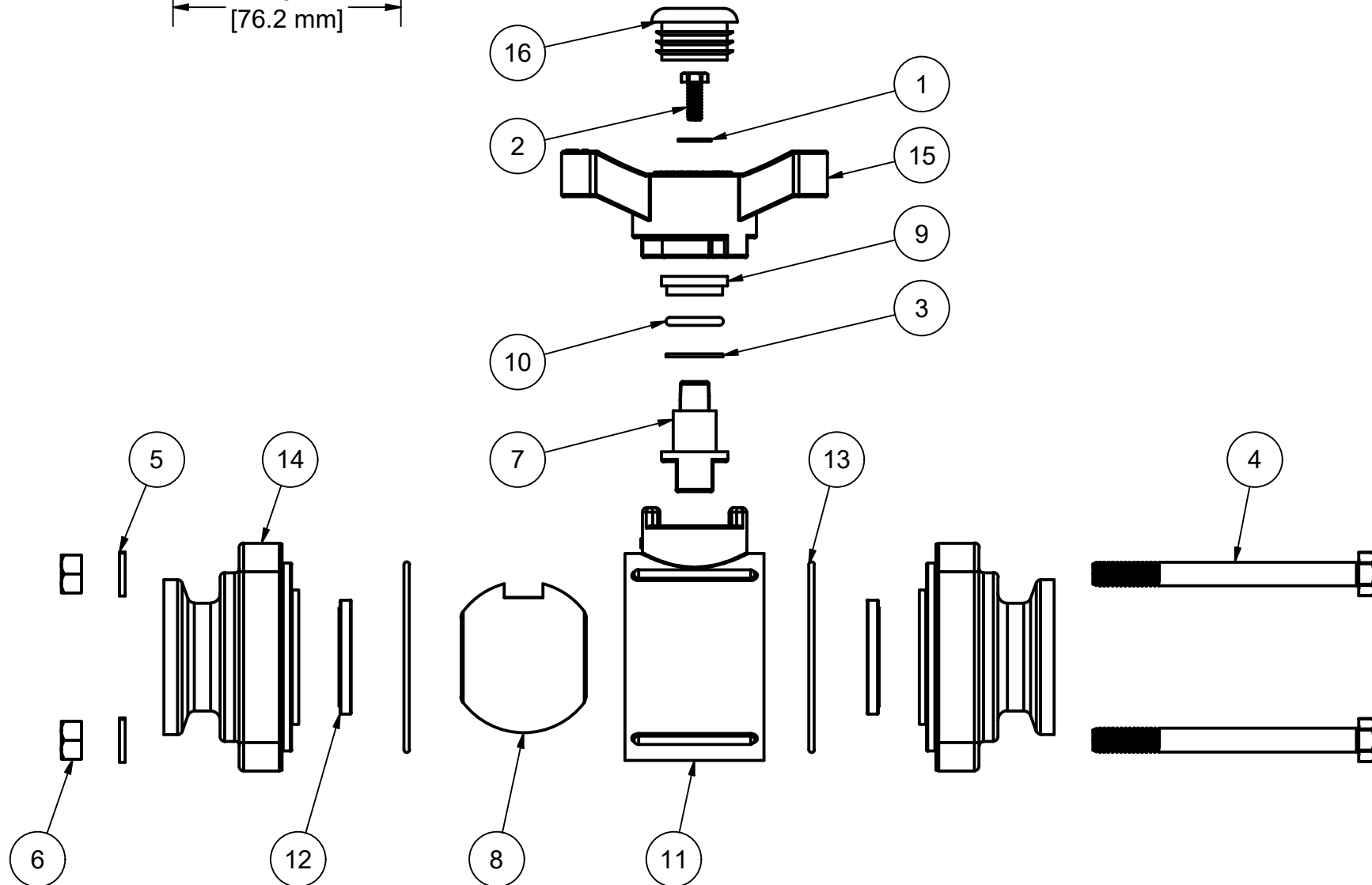

THIS DRAWING AND ALL INFORMATION CONTAINED THEREON ARE THE EXCLUSIVE PROPERTY OF BANJO CORPORATION.

UNLESS SPECIFICALLY NOTED, THIS DRAWING AND ITEMS SHOWN ON THIS DRAWING ARE SUBJECT TO CHANGE AT ANY TIME.



BANJO CORPORATION
A UNIT OF IDEX CORPORATION
150 BANJO DRIVE, CRAWFORDSVILLE, IN 47933
WEB SITE: WWW.BANJOCORP.COM
E-MAIL: BANJOSALES@IDEXCORP.COM

DESCRIPTION:
1" FP MANIFOLD FLANGED VALVE

PART NUMBER:
MVT100CF