

SECTION A-A  
SCALE 1 : 1

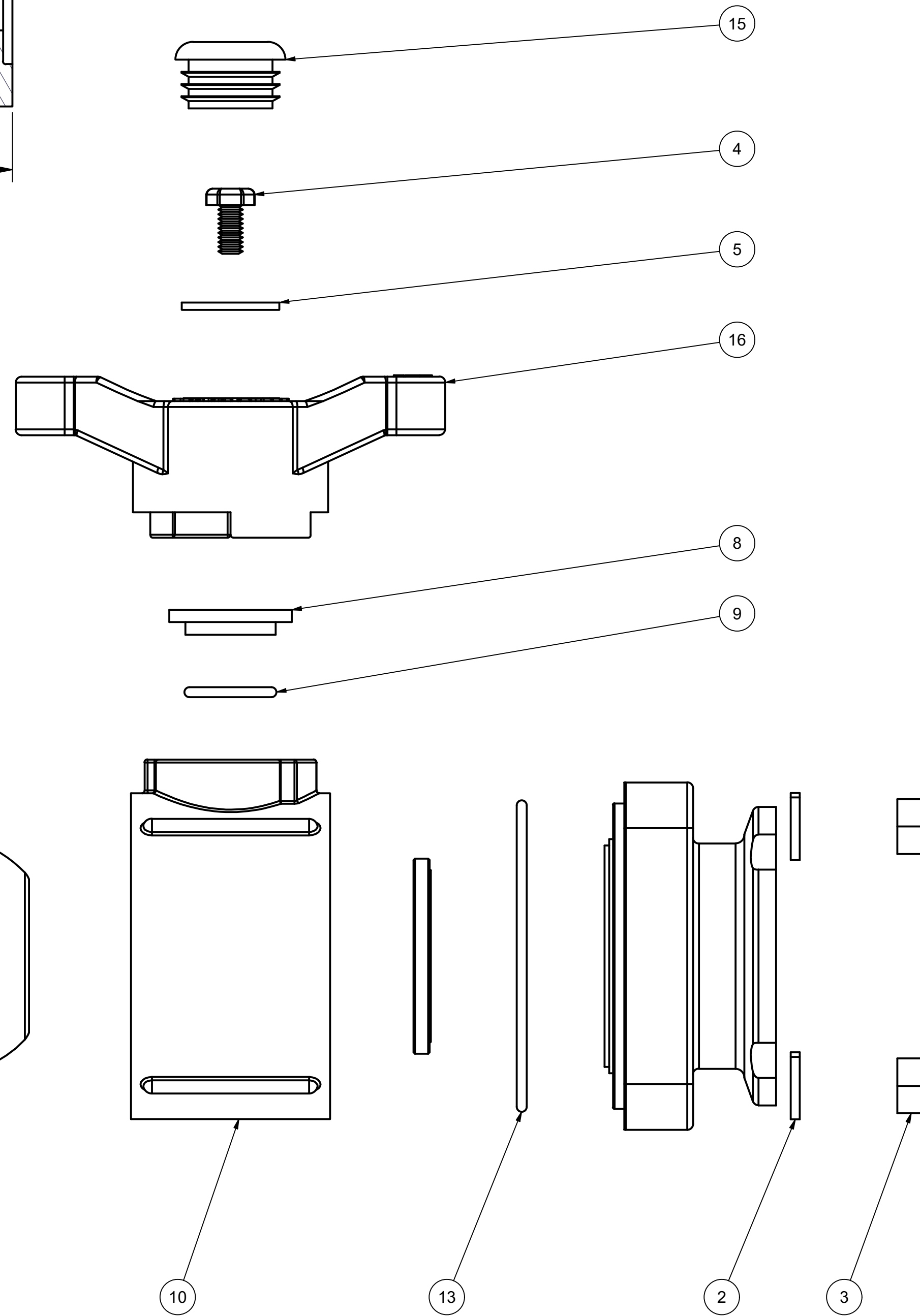

Parts List			
ITEM	QTY	PART NUMBER	DESCRIPTION
1	4	V20017	3/8-16 X 4" HHCS
2	4	V20018	3/8" LOCKWASHER
3	4	V20019	3/8-16 HEX NUT
4	1	V20020	2" handle Bolt
5	1	V20021	Handle Washer
6	1	V20060	VALVE STEM THRUST BEARING
7	1	V20151M	BALL STEM FOR 1-1/2" & 2" VALVE
8	1	V20159	2" STEM BUSHING
9	1	V20163	AS568A -116 O-RING, FKM, BROWN
10	1	V20254	2" VALVE BODY
11	1	V20255A	2" Valve Ball
12	2	V20258A	2" Valve Seat
13	2	V20264	AS568A -151 O-RING, FKM, BROWN
14	2	V20294	2" FLANGE ENDPLATE, MACHINED
15	1	V20353C	1 1/8" CAPPLUG
16	1	V20353T	2" T-Handle
17	1 (NS)	VL1001	150 PSI PRESSURE LABEL FKM SEALS

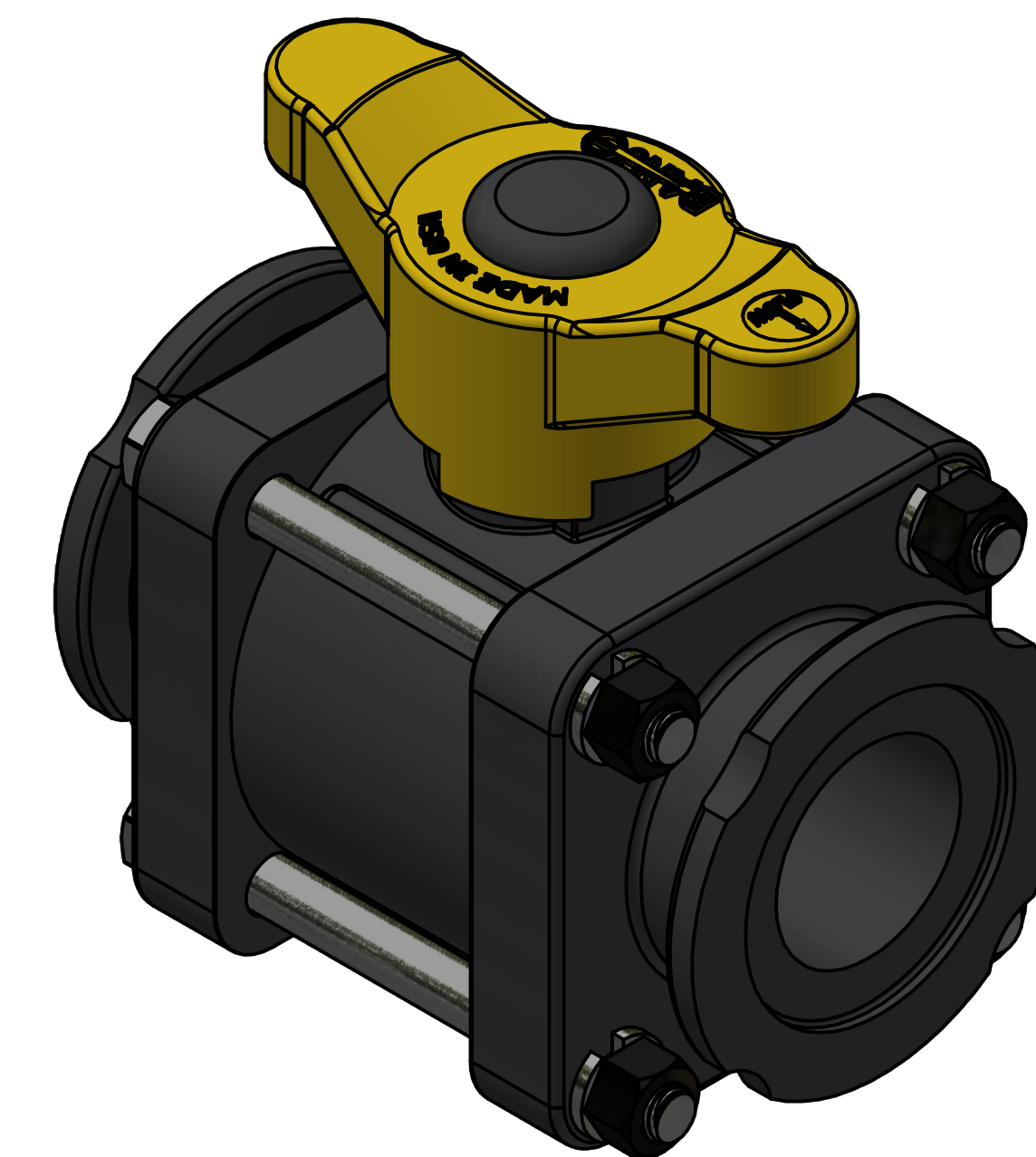

THIS DRAWING AND ALL INFORMATION CONTAINED THEREON ARE THE EXCLUSIVE PROPERTY OF BANJO CORPORATION.

UNLESS SPECIFICALLY NOTED, THIS DRAWING AND ITEMS SHOWN ON THIS DRAWING ARE SUBJECT TO CHANGE AT ANY TIME.

BANJO CORPORATION  
150 BANJO DRIVE, CRAWFORDSVILLE, IN 47933  
WEB SITE: WWW.BANJO.CORP.COM  
E-MAIL: BANJOSALES@IDEXCORP.COM

DESCRIPTION  
**2" VALVE w/ C-FLANGE & T-HANDLE**

PART NUMBER  
**MVT200CF**