

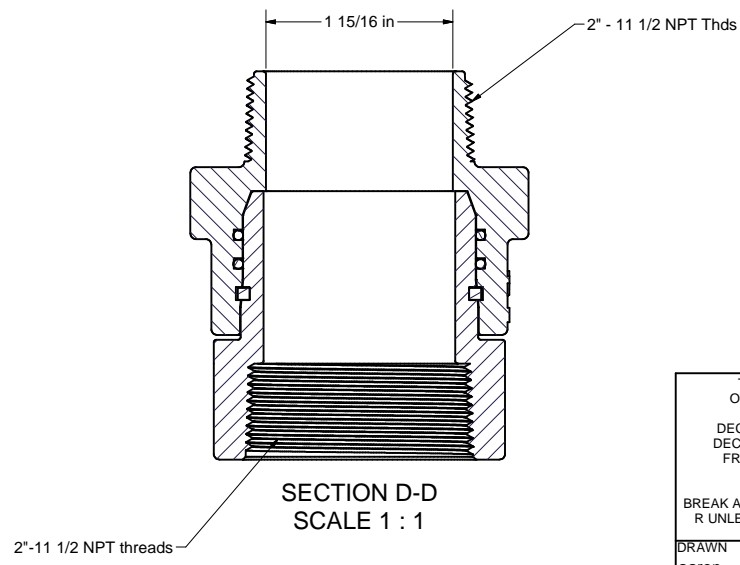

			Parts List	
ITEM	QTY	PART NUMBER	DESCRIPTION	
1	1	SW221	2" FP Female Thread Male Swivel End	
2	1	SW222	2" FP Male Thread Female Swivel End	
3	2	A143V	2-143 FKM O-Ring	
4	1	SW105	Swivel Drive Pin	
5	1	SW223	2" FP Swivel Thrust Washer	

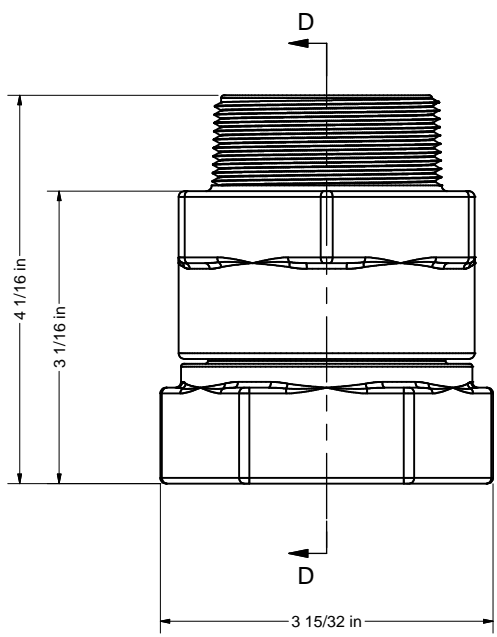
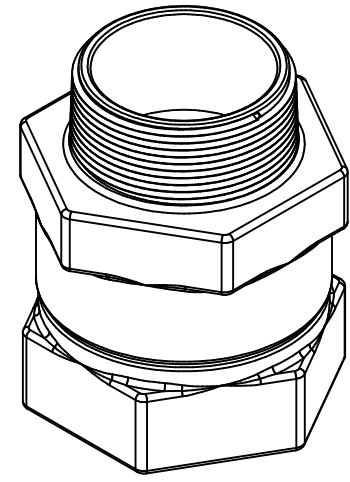
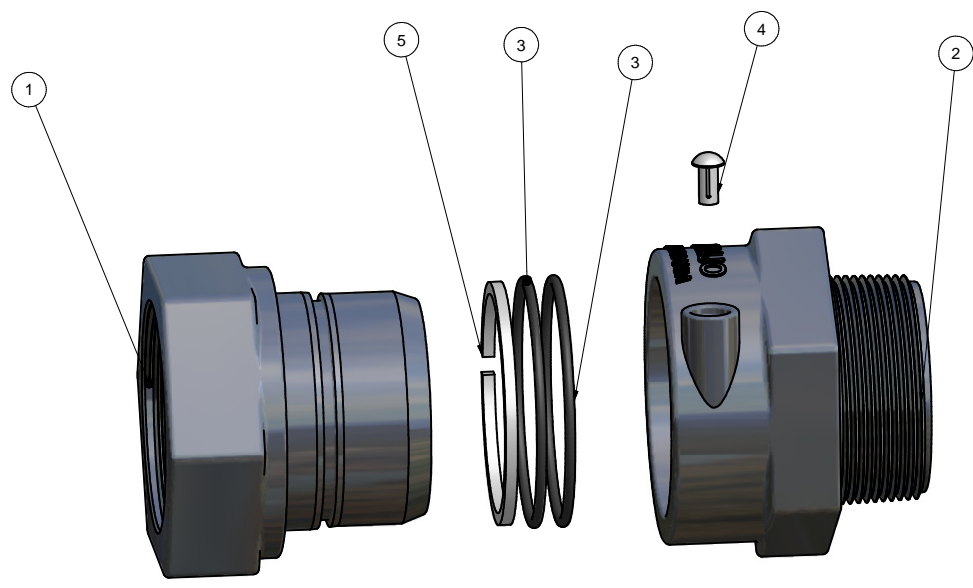

TOLERANCE UNLESS OTHERWISE SPECIFIED			
DECIMALS 0.00 = +/- 0.010 DECIMALS 0.000 = +/- 0.005 FRACTIONS 1/X = +/- 1/32 ANGLES = +/- 1			
BREAK ALL SHOWN CORNERS W/ 1/32 R UNLESS OTHERWISE SPECIFIED		BANJO CORPORATION 150 BANJO DRIVE, CRAWFORDSVILLE, IN 47933	
DRAWN	aaron	TITLE	
CHECKED	6/11/2009	2" FP Male Thread x Female Thread Swivel	
QA		SIZE	DWG NO
MFG		C	SW220
APPROVED		SCALE	REV
		SHEET 2 OF 2	