

Parts List			
ITEM	QTY	PART NUMBER	DESCRIPTION
1	1	LST1225D	225 PSI DECAL (N/S)
2	1	UV15150	1 1/2" UV RING
3	1	UV15151	UV STEM
4	1	UV15153	UV HANDLE
5	2	UV15163	#114 O'RING, EPDM
6	1	UV15220	#6 X 5/8" HWH SMS
7	1	UV15244	1 1/4" UNION VALVE, FKM
8	1	UV15255	1.5" UNION VALVE BALL, TUMBLED
9	1	UV15264	#230 O'RING
10	1	UV15267	1 1/4" UV END PLATE
11	2	V20258	2" BALL SEAT

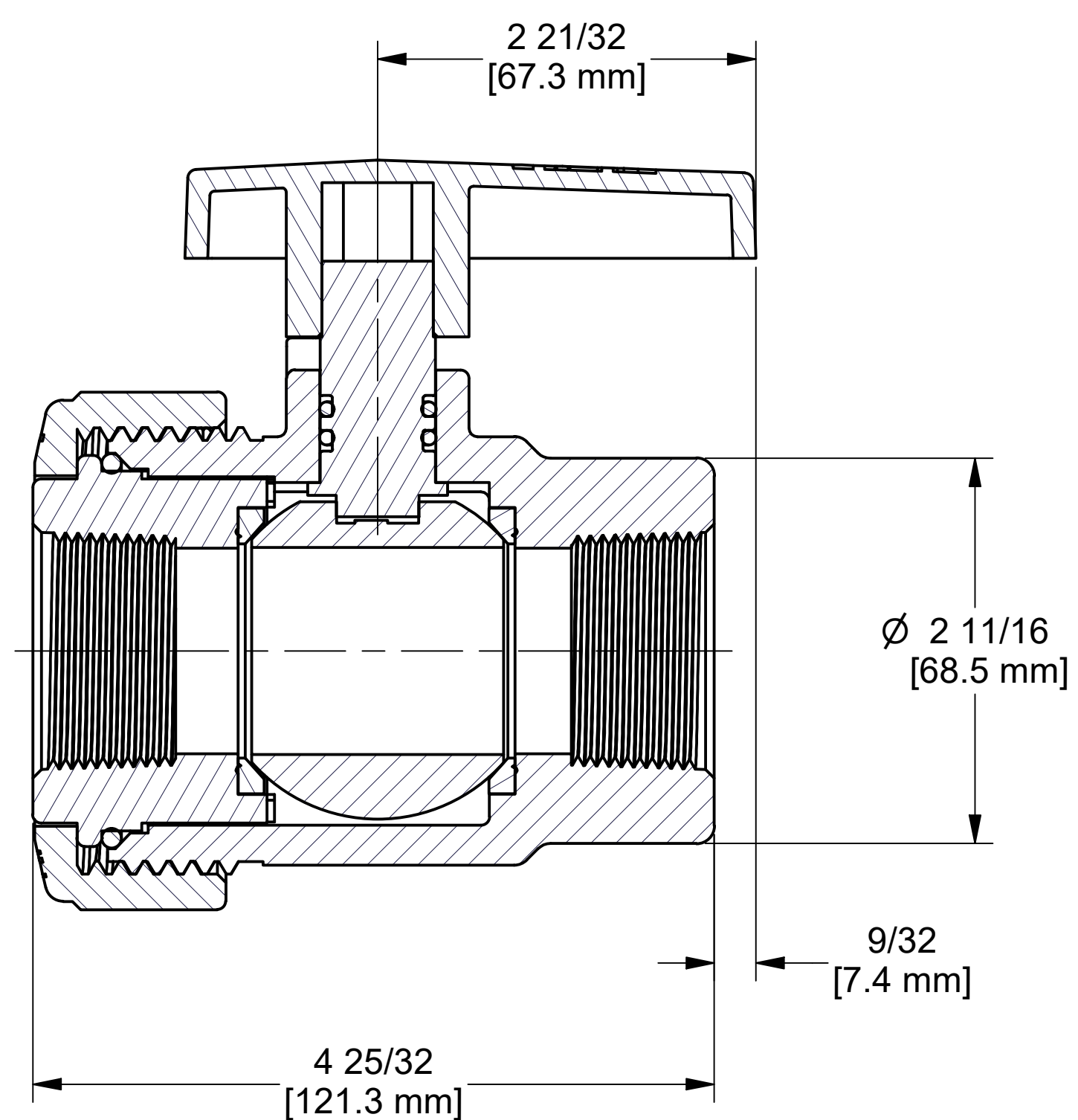
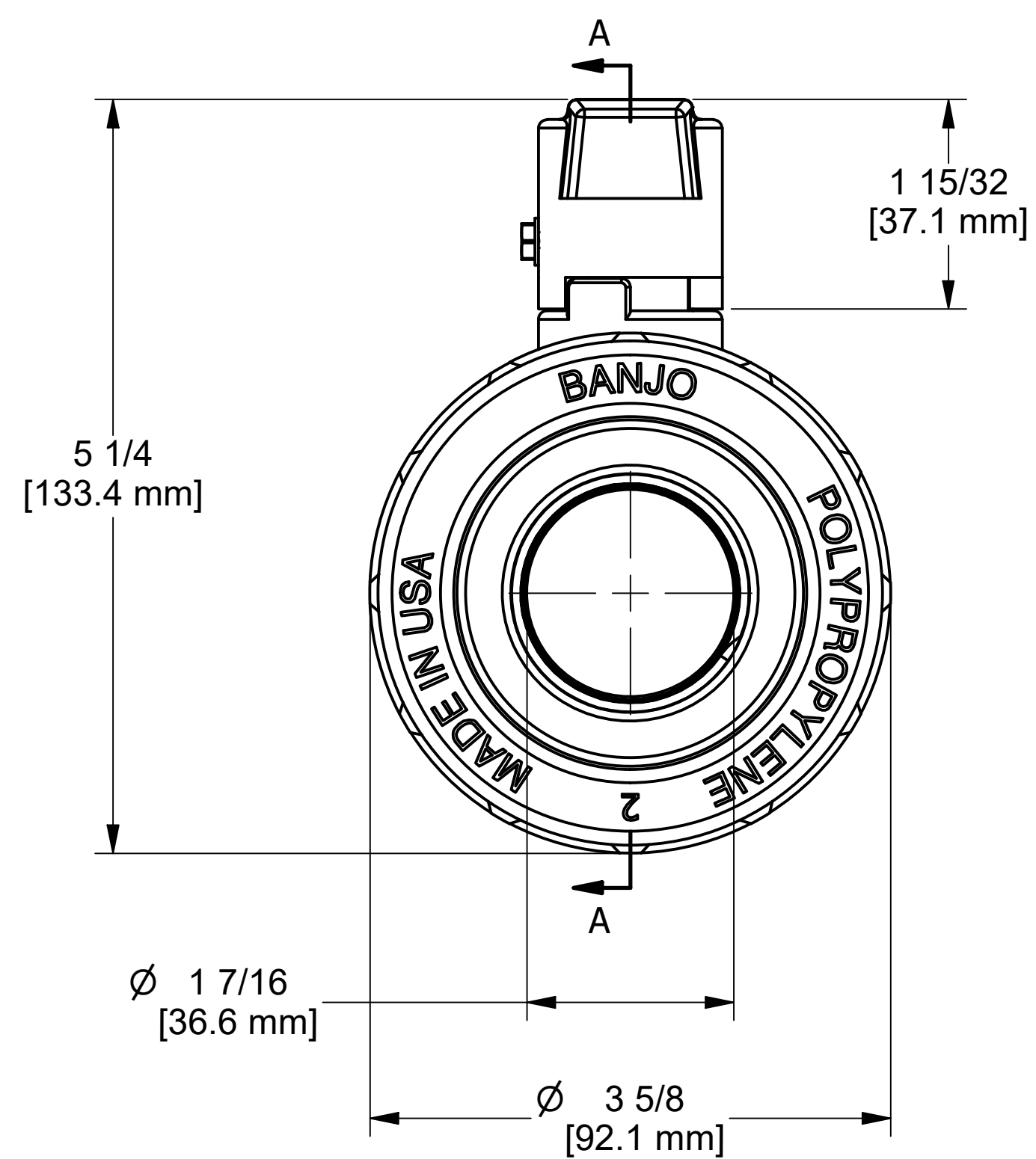
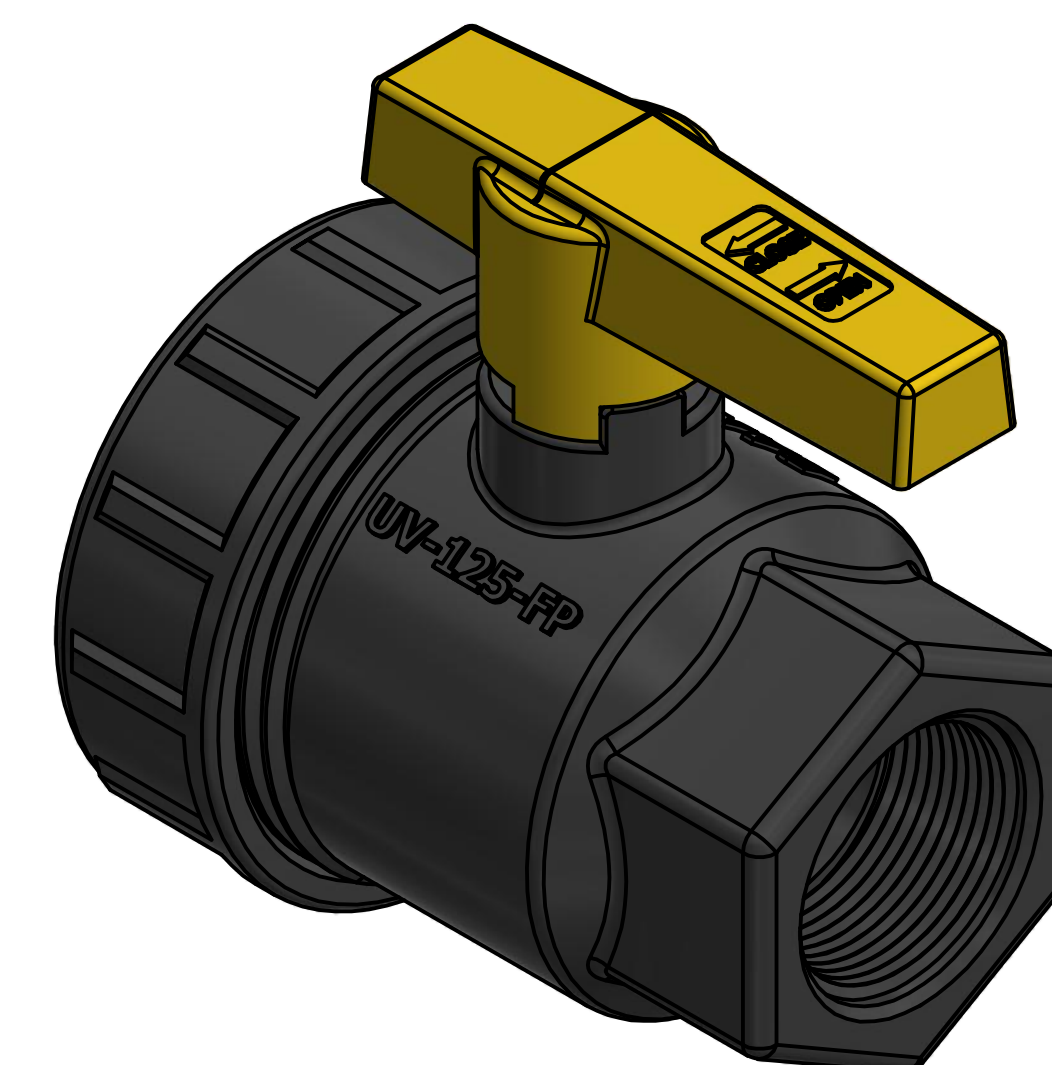

SECTION A-A
SCALE 1:1

THIS DRAWING AND ALL INFORMATION CONTAINED THEREON ARE THE EXCLUSIVE PROPERTY OF BANJO CORPORATION.

UNLESS SPECIFICALLY NOTED, THIS DRAWING AND ITEMS SHOWN ON THIS DRAWING ARE SUBJECT TO CHANGE AT ANY TIME.



BANJO CORPORATION
150 BANJO DRIVE, CRAWFORDSVILLE, IN 47933
WEB SITE: WWW.BANJO.CORP.COM
E-MAIL: BANJOSALES@IDEXCORP.COM

DESCRIPTION
1 1/4" NPT UNION VALVE

PART NUMBER
UV125FP