

PARTS LIST			
ITEM	QTY	PART NUMBER	DESCRIPTION
1	1	050DECAL	LOGO DECAL (N/S)
2	1	SW10	#10 WASHER
3	1	V07020	#10-24x0.50 HHCS 18-8SS
4	1	V10060	THRUST BEARING
5	4	V10117	5/16 - 18 X 3 1/2" HHCS
6	4	V10118	5/16" LOCKWASHER
7	4	V10119	5/16" HEX NUT
8	1	V10151	1" VALVE STEM
9	1	V10159	STEM BUSHING
10	1	V10163	AS568A -113 O-RING, FKM, BROWN
11	2	V10258	3" FP BALL SEAT
12	2	V10264	AS568A -036 O-RING, FKM, BROWN
13	1	V10353TB	BOTTOM LOAD T-HANDLE
14	1	V10354B	BOTTOM LOAD VALVE BODY, MACHINED
15	1	V10355B	1" FP BL BALL, TUMBLED
16	2	V10357	1" NPT ENDPLATE, MACHINED
17	1	V20353C	1 1/8" CAPLUG
18	1	VL1017	225 PSI DECAL (N/S)

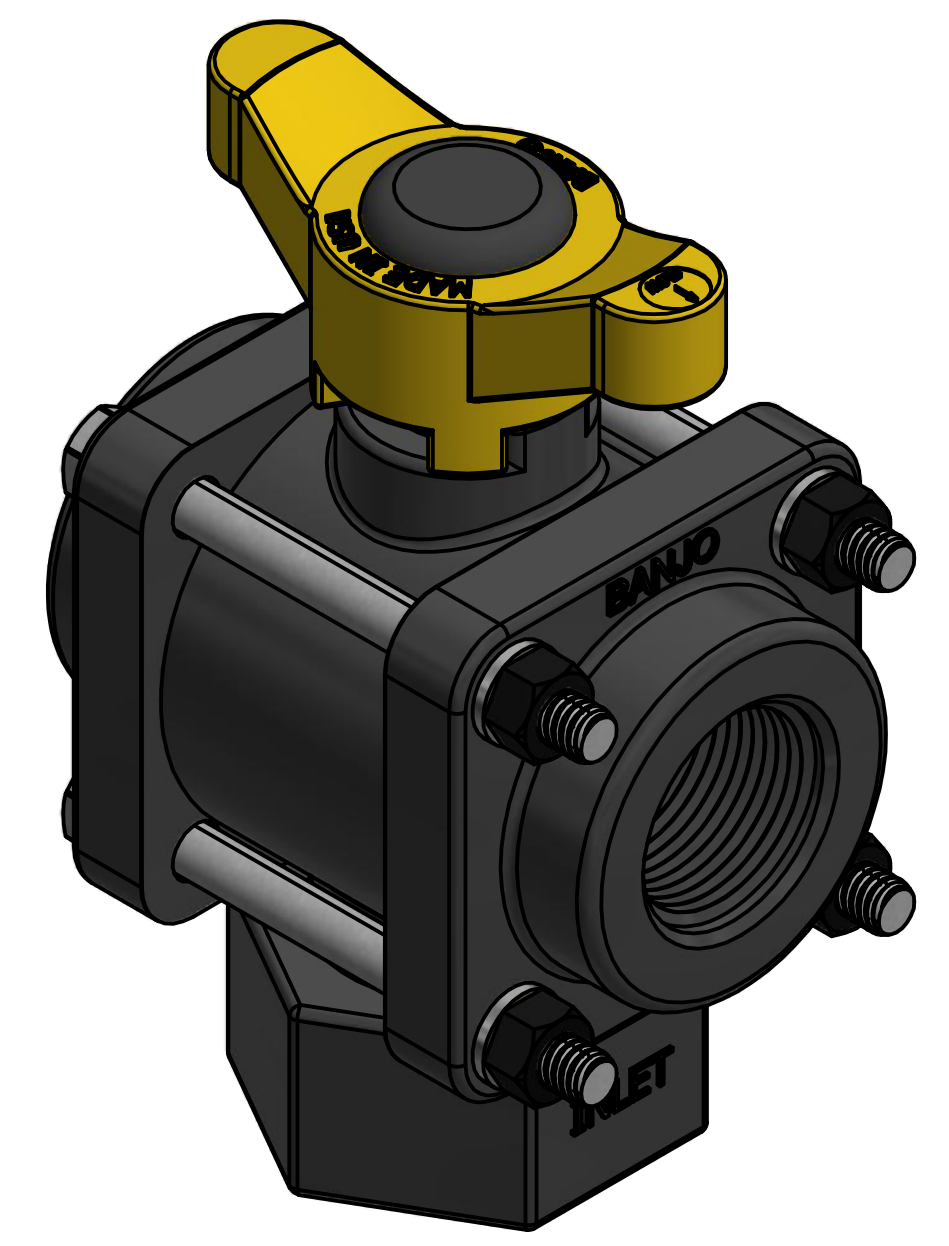
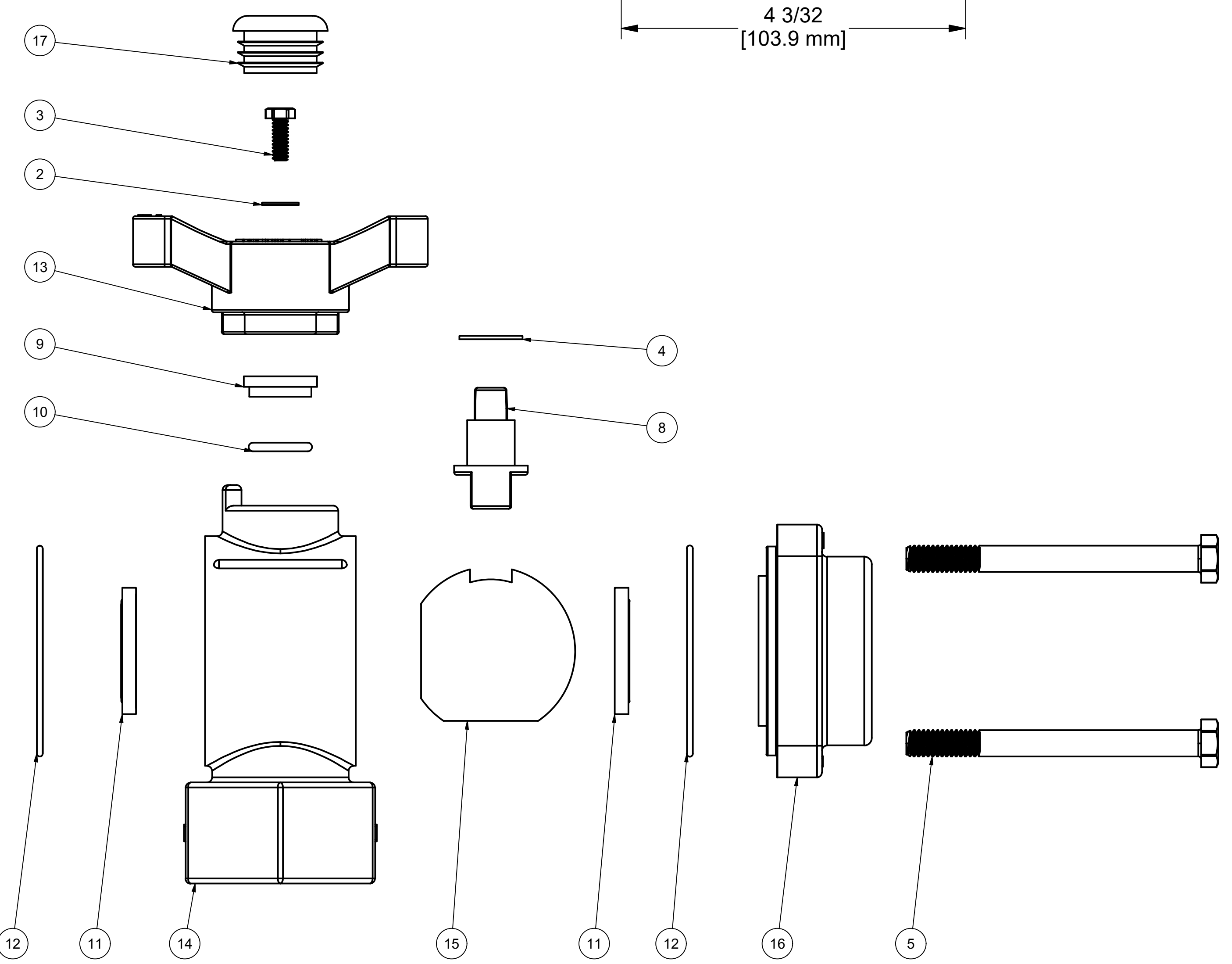

THIS DRAWING AND ALL INFORMATION CONTAINED THEREON ARE THE EXCLUSIVE PROPERTY OF BANJO CORPORATION.

UNLESS SPECIFICALLY NOTED, THIS DRAWING AND ITEMS SHOWN ON THIS DRAWING ARE SUBJECT TO CHANGE AT ANY TIME.

BANJO CORPORATION
 150 BANJO DRIVE, CRAWFORDSVILLE, IN 47933
 WEB SITE: WWW.BANJO.CORP.COM
 E-MAIL: BANJOSALES@IDEXCORP.COM

DESCRIPTION
 1" BOTTOM LOAD VALVE ASSY., FKM

PART NUMBER
 V100BL