

PARTS LIST			
ITEM	QTY	PART NUMBER	DESCRIPTION
1	1 (NS)	050DECAL	DECAL
2	4	V20017	3/8-16 X 4" HHCS
3	4	V20018	3/8" LOCKWASHER
4	4	V20019	3/8-16 HEX NUT
5	1	V20020	2" HANDLE BOLT
6	1	V20021	HANDLE WASHER
7	1	V20060	VALVE STEM THRUST BEARING
8	1	V20151M	BALL STEM FOR 1-1/2" & 2" VALVE
9	1	V20159	2" STEM BUSHING
10	1	V20163	AS568A -116 O-RING, FKM, BROWN
11	2	V20264	AS568A -151 O-RING, FKM, BROWN
12	2	V20267	1 1/4" NPT ENDPLATE, MACHINED
13	1	V20344S	1 1/4" NPT SL VALVE BODY, MACHINED
14	1	V20353C	1 1/8" CAPLUG
15	1	V20353TS	2" SIDE LOAD T-HANDLE
16	1	V20355S	2" 3-WAY SL BALL, TUMBLED
17	2	VE20258A	2" VE SEAT TFM

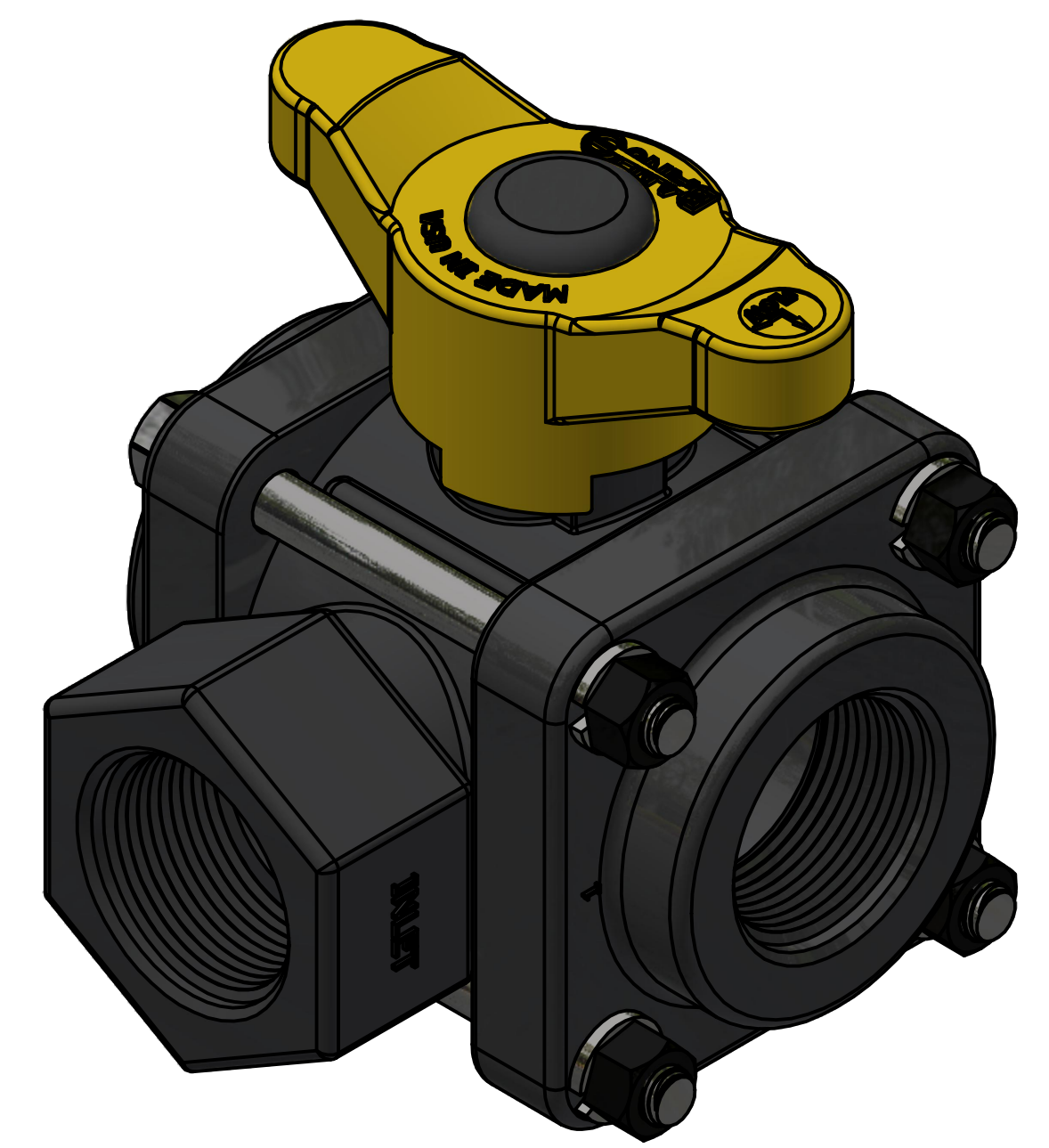

THIS DRAWING AND ALL INFORMATION CONTAINED THEREON ARE THE EXCLUSIVE PROPERTY OF BANJO CORPORATION.

UNLESS SPECIFICALLY NOTED, THIS DRAWING AND ITEMS SHOWN ON THIS DRAWING ARE SUBJECT TO CHANGE AT ANY TIME.

BANJO CORPORATION
150 BANJO DRIVE, CRAWFORDSVILLE, IN 47933
WEB SITE: WWW.BANJO.CORP.COM
E-MAIL: BANJOSALES@IDEXCORP.COM

DESCRIPTION
1 1/4" NPT SIDE LOAD VALVE ASSEMBLY

PART NUMBER
V125SL