

PARTS LIST				
ITEM	QTY	PART NUMBER	DESCRIPTION	
1	4	V20017	3/8-16 X 4" HHCS	
2	4	V20018	3/8" LOCKWASHER	
3	4	V20019	3/8-16 HEX NUT	
4	1	V20020	2" handle Bolt	
5	1	V20021	Handle Washer	
6	1	V20060	VALVE STEM THRUST BEARING	
7	1	V20151M	BALL STEM FOR 1-1/2" & 2" VALVE	
8	1	V20153	1-1/2" & 2" VALVE HANDLE	
9	1	V20159	2" STEM BUSHING	
10	1	V20163	AS568A -116 O-RING, FKM, BROWN	
11	1	V20254	2" VALVE BODY	
12	1	V20255A	2" Valve Ball	
13	2	V20257B	1-1/2" BSPC ENDPLATE, MACHINED	
14	2	V20258A	2" Valve Seat	
15	2	V20264	AS568A -151 O-RING, FKM, BROWN	

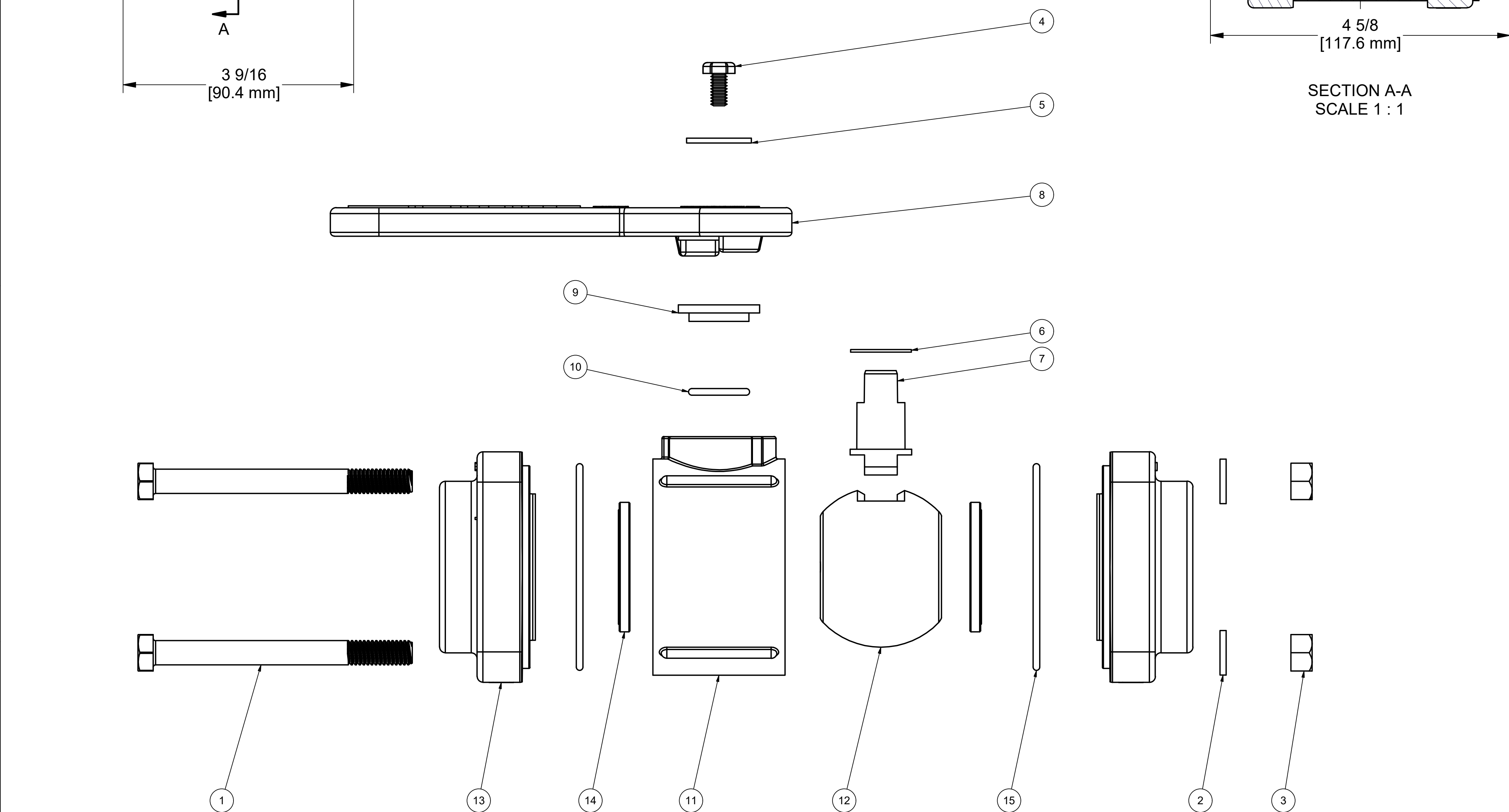

THIS DRAWING AND ALL INFORMATION CONTAINED THEREON ARE THE EXCLUSIVE PROPERTY OF BANJO CORPORATION.

UNLESS SPECIFICALLY NOTED, THIS DRAWING AND ITEMS SHOWN ON THIS DRAWING ARE SUBJECT TO CHANGE AT ANY TIME.

BANJO CORPORATION
 150 BANJO DRIVE, CRAWFORDSVILLE, IN 47933
 WEB SITE: WWW.BANJO.CORP.COM
 E-MAIL: BANJOSALES@DEXCORP.COM

DESCRIPTION
 1-1/2" VALVE BSP

PART NUMBER
 V150B