

SECTION A-A
SCALE 1 : 1

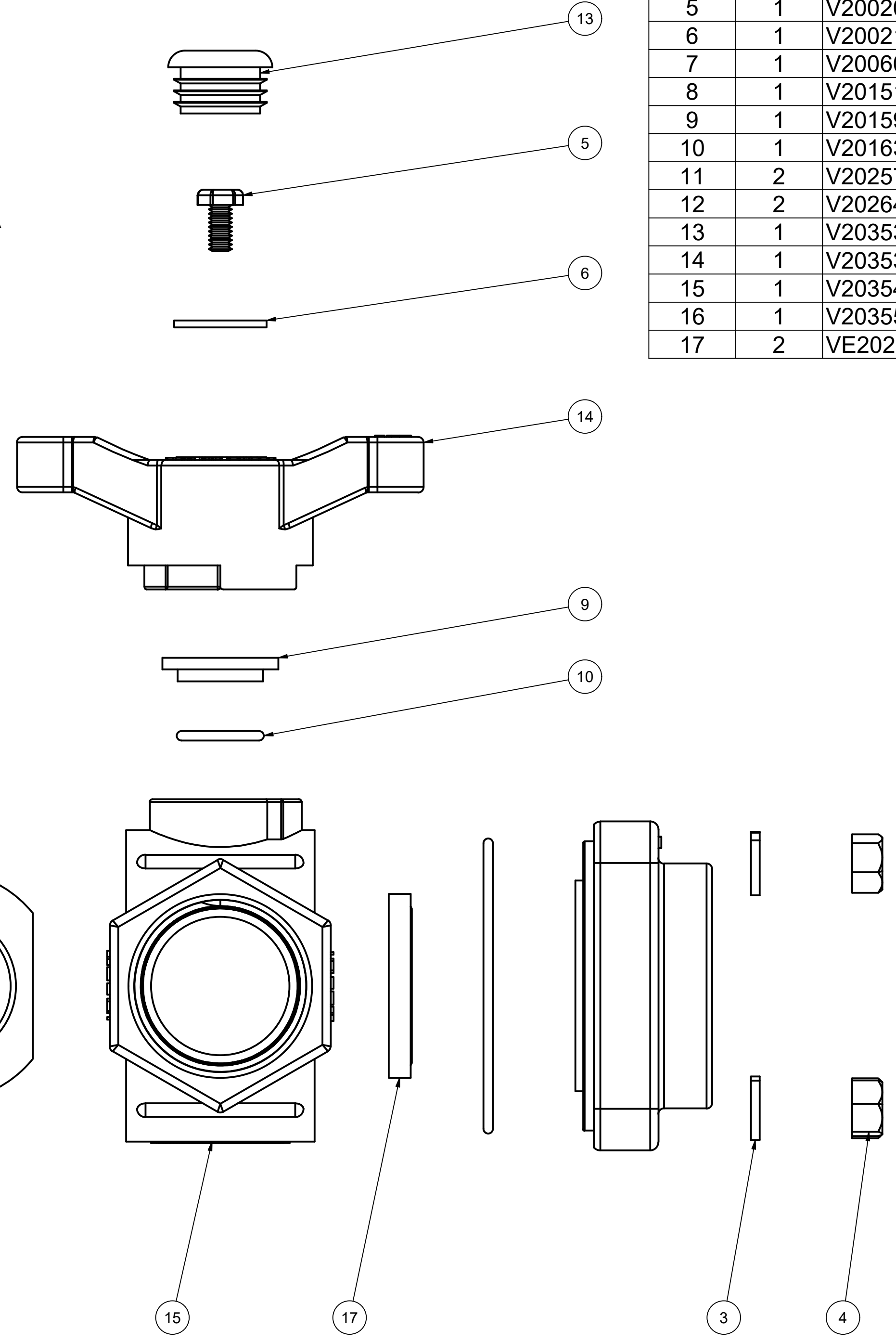

Parts List			
ITEM	QTY	PART NUMBER	DESCRIPTION
1	1 (NS)	050DECAL	Banjo Logo Decal
2	4	V20017	3/8-16 X 4" HHCS
3	4	V20018	3/8" LOCKWASHER
4	4	V20019	3/8-16 HEX NUT
5	1	V20020	2" handle Bolt
6	1	V20021	Handle Washer
7	1	V20060	VALVE STEM THRUST BEARING
8	1	V20151M	VALVE STEM
9	1	V20159	2" STEM BUSHING
10	1	V20163	AS568A -116 O-RING, FKM, BROWN
11	2	V20257	1 1/2" FNPT ENDPLATE, MACHINED
12	2	V20264	AS568A -151 O-RING, FKM, BROWN
13	1	V20353C	1 1/8" CAPLUG
14	1	V20353TS	2" Side Load T-Handle
15	1	V20354S	1 1/2" NPT SL VALVE BODY, MACHINED
16	1	V20355S	2" 3-WAY SL BALL, TUMBLED
17	2	VE20258A	2" VE Seat TFM

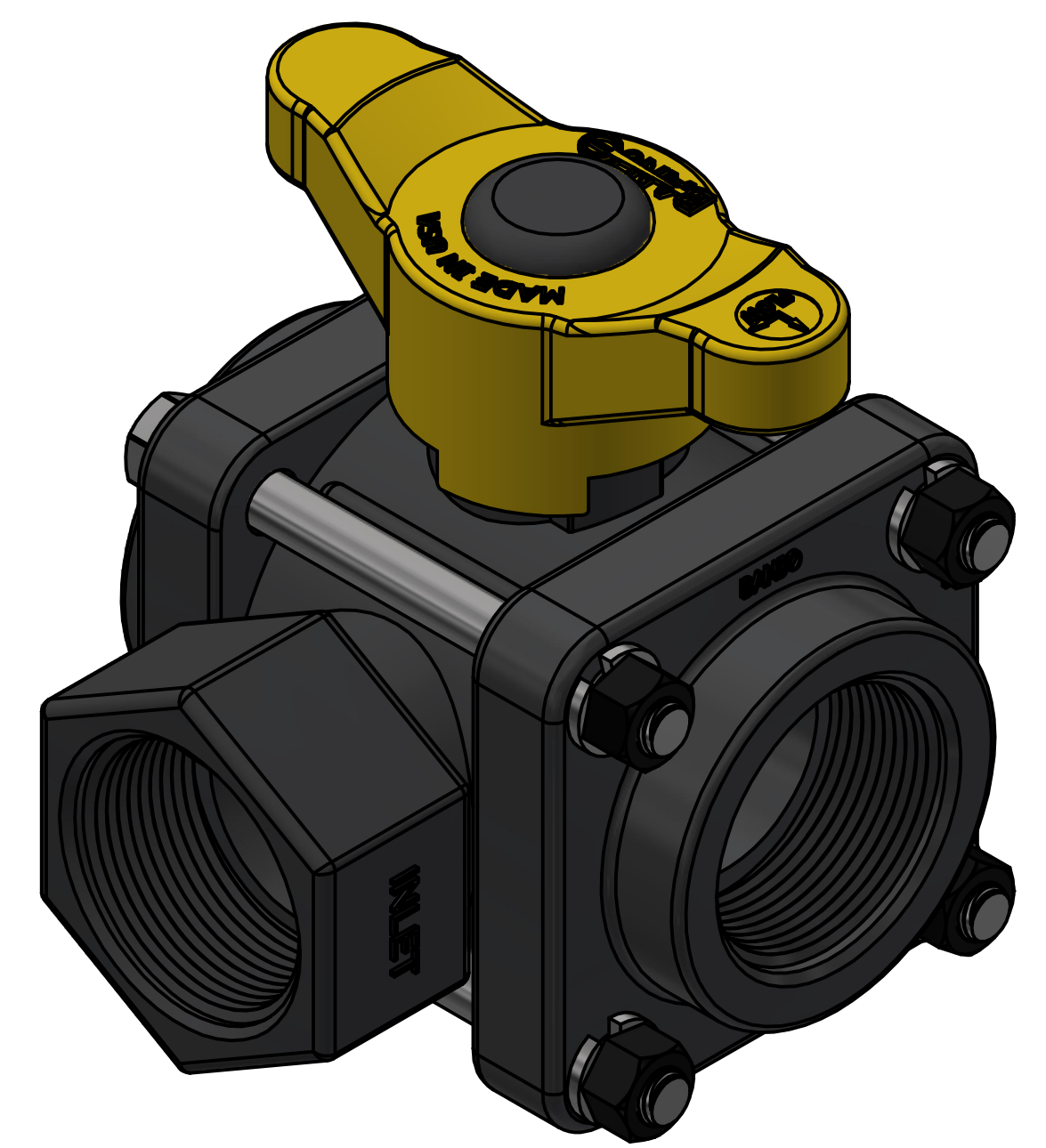

THIS DRAWING AND ALL INFORMATION CONTAINED THEREON ARE THE EXCLUSIVE PROPERTY OF BANJO CORPORATION.
UNLESS SPECIFICALLY NOTED, THIS DRAWING AND ITEMS SHOWN ON THIS DRAWING ARE SUBJECT TO CHANGE AT ANY TIME.

BANJO CORPORATION
150 BANJO DRIVE, CRAWFORDSVILLE, IN 47933
WEB SITE: WWW.BANJO.CORP.COM
E-MAIL: BANJOSALES@IDEXCORP.COM

DESCRIPTION
1 1/2" SIDE LOAD VALVE

PART NUMBER
V150SL