

PARTS LIST			
ITEM	QTY	PART NUMBER	DESCRIPTION
1	6	V20018	3/8" LOCKWASHER
2	6	V20019	3/8" HEX NUT
3	6	V25017	3/8-16 X 4 1/2" HHCS
4	1	V25020	3/8" Handle Bolt
5	1	V25060	VALVE STEM THRUST BEARING
6	1	V25121	3/8" Fender Washer
7	1	V25151B	STEM 2"FP & 3"FP, MACHINED
8	1	V25153	2" FP HANDLE
9	1	V25160	Stem Bushing
10	1	V25163	AS568A -214 O-RING, FKM, BROWN
11	1	V25254	2" FP VALVE BODY
12	1	V25255A	2" FP VALVE BALL, TUMBLED
13	2	V25256B	2" BSPC FP ENDPLATE, MACHINED
14	2	V25258A	2" FP Valve Seat
15	2	V25264	CUSTOM O-RING, ID:3.575", CS: 0.103, FKM, BROWN
16	1	VL1001	PRESSURE LABEL (N/S)

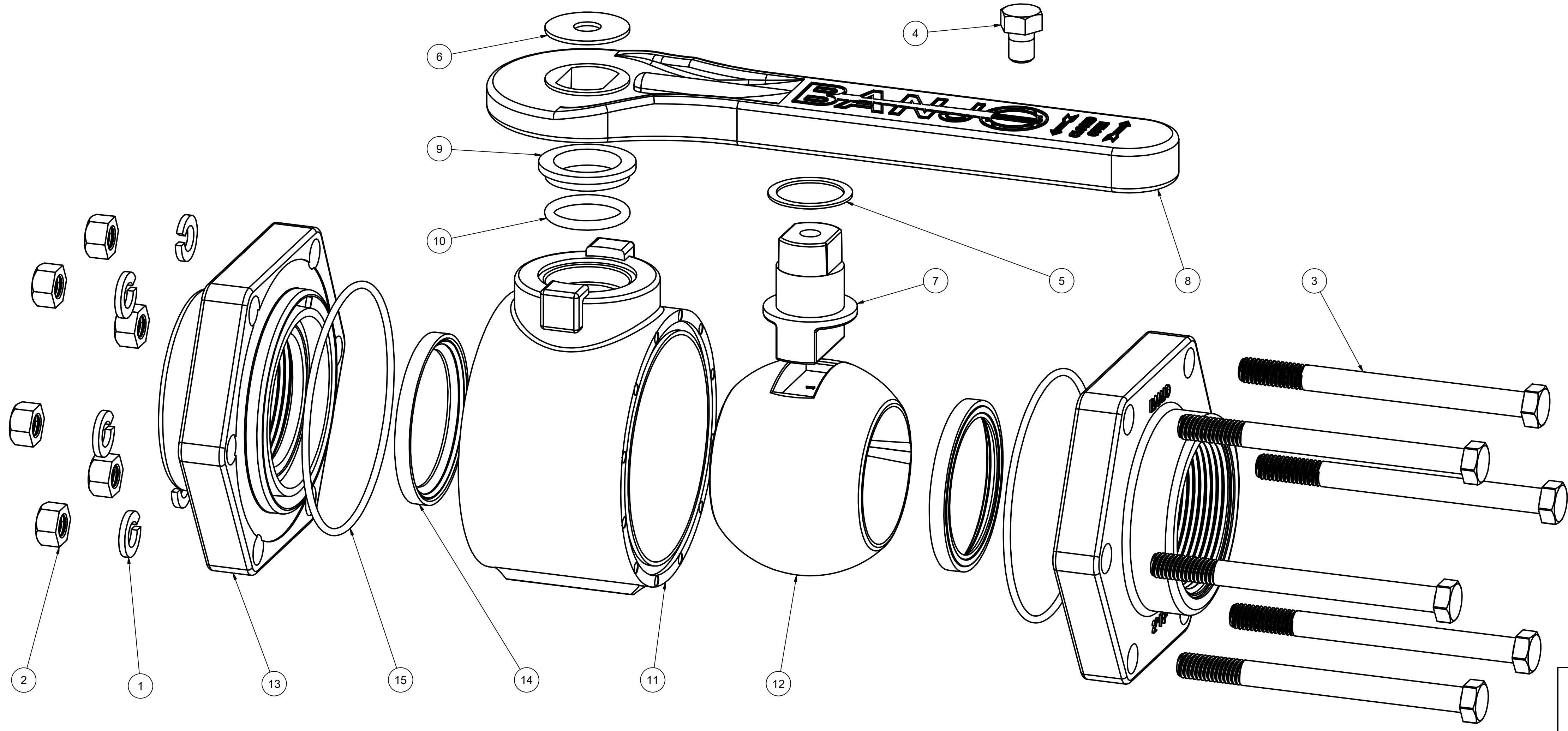

THIS DRAWING AND ALL INFORMATION CONTAINED THEREON ARE THE EXCLUSIVE PROPERTY OF BANJO CORPORATION.

UNLESS SPECIFICALLY NOTED, THIS DRAWING AND ITEMS SHOWN ON THIS DRAWING ARE SUBJECT TO CHANGE AT ANY TIME.

BANJO CORPORATION  
 150 BANJO DRIVE, CRAWFORDSVILLE, IN 47933  
 WEB SITE: WWW.BANJO.CORP.COM  
 E-MAIL: BANJOSALES@IDEXCORP.COM

DESCRIPTION  
**2" FULL PORT VALVE BSP**

PART NUMBER  
**V200FPB**