

Parts List			
ITEM	QTY	PART NUMBER	DESCRIPTION
1	4	V20017	3/8-16 X 4" HHCS
2	4	V20018	3/8" LOCKWASHER
3	4	V20019	3/8-16 HEX NUT
4	1	V20020	2" handle Bolt
5	1	V20021	Handle Washer
6	1	V20060	VALVE STEM THRUST BEARING
7	1	V20151M	VALVE STEM
8	1	V20152	ANGLE HANDLE
9	1	V20159	2" STEM BUSHING
10	1	V20163	AS568A -116 O-RING, FKM, BROWN
11	1	V20166	1 1/2" NPT X 8" NOZZLE PIPE
12	1	V20254	2" VALVE BODY
13	1	V20255A	2" Valve Ball
14	1	V20257	1 1/2" FNPT ENDPLATE, MACHINED
15	1	V20258	2" VALVE BALL SEAT
16	1	V20258A	2" Valve Seat
17	1	V20262	1 1/2" ANGLE FLANGE END PLATE
18	2	V20264	AS568A -151 O-RING, FKM, BROWN

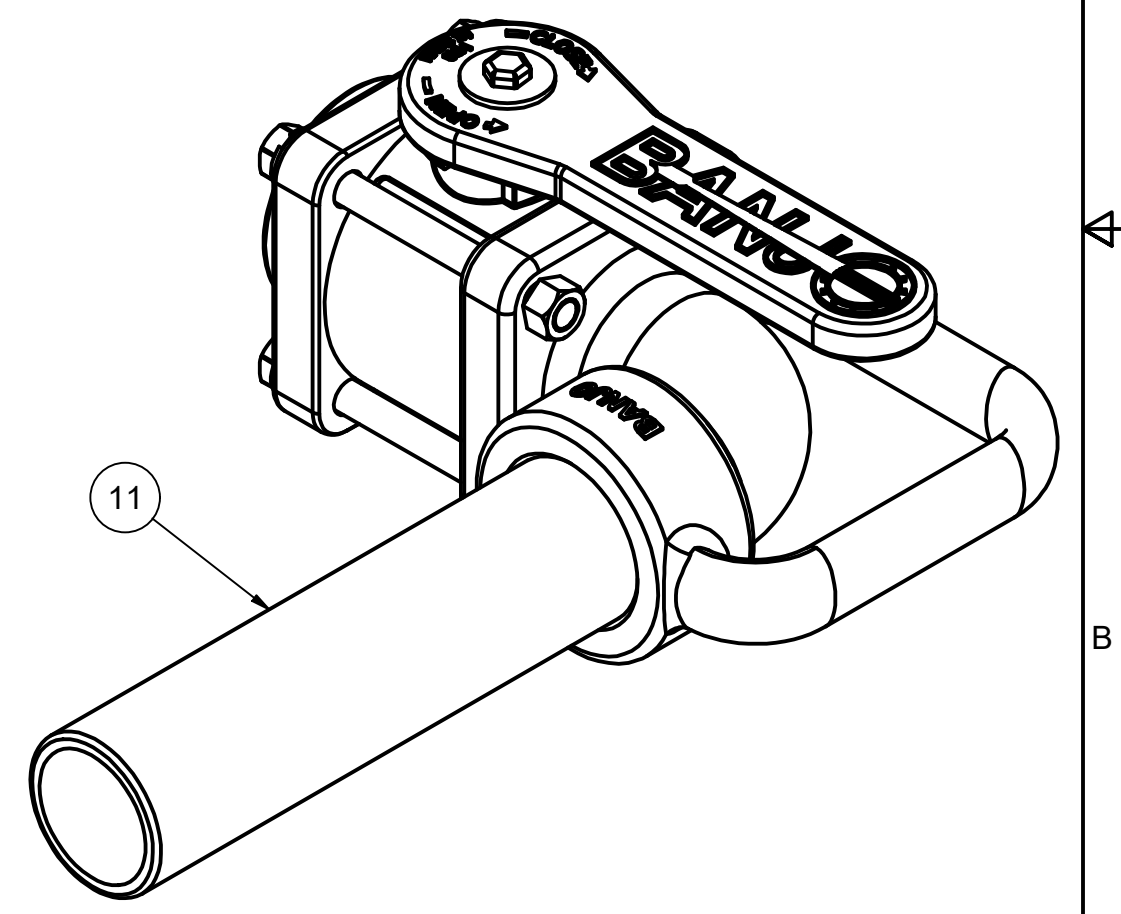
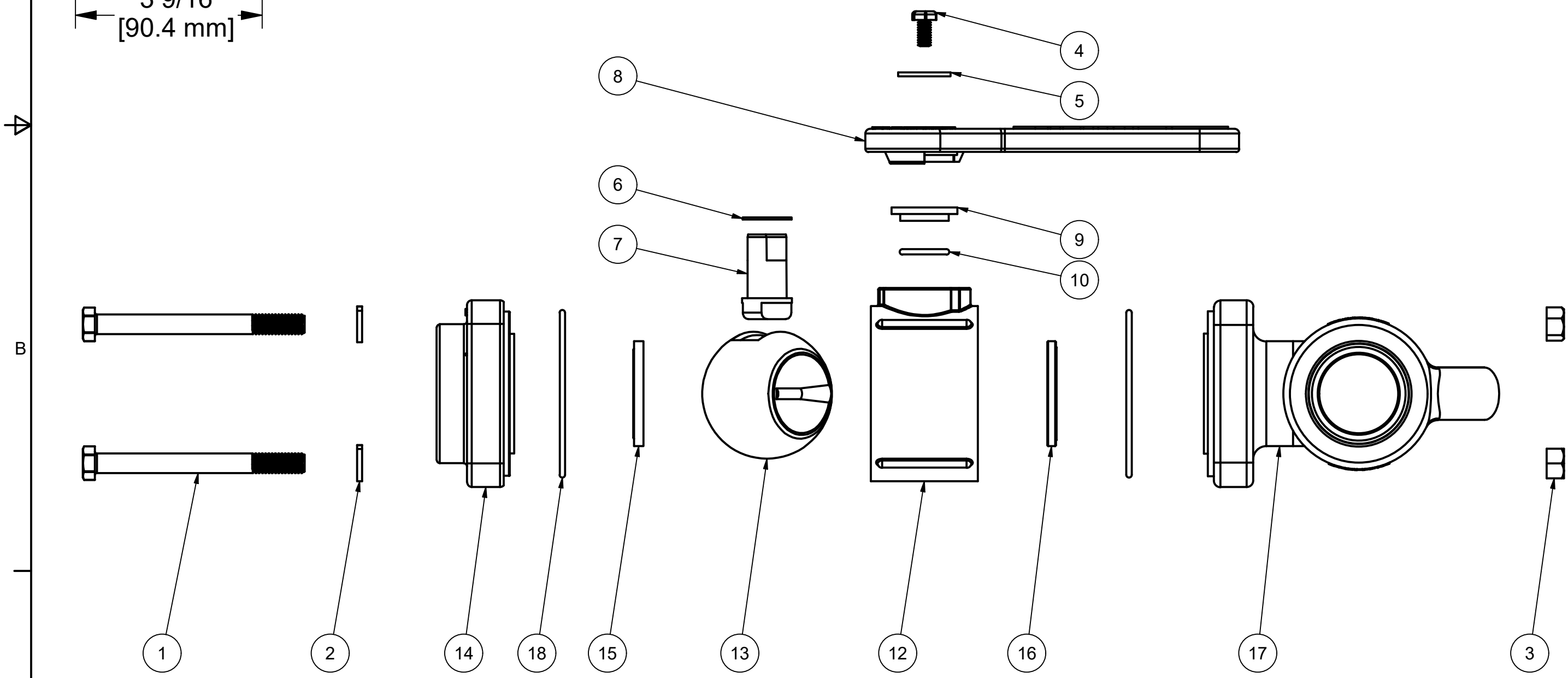

THIS DRAWING AND ALL INFORMATION CONTAINED THEREON ARE THE EXCLUSIVE PROPERTY OF BANJO CORPORATION.

UNLESS SPECIFICALLY NOTED, THIS DRAWING AND ITEMS SHOWN ON THIS DRAWING ARE SUBJECT TO CHANGE AT ANY TIME.

BANJO CORPORATION
 150 BANJO DRIVE, CRAWFORDSVILLE, IN 47933
 WEB SITE: WWW.BANJOCORP.COM
 E-MAIL: BANJOSALES@IDEXCORP.COM

DESCRIPTION
 1-1/2" FPT x 1-1/2" PORT

PART NUMBER
 VA150