

Parts List			
ITEM	QTY	PART NUMBER	DESCRIPTION
1	4	V20017	3/8-16 X 4" HHCS
2	4	V20018	3/8" LOCKWASHER
3	4	V20019	3/8-16 HEX NUT
4	1	V20020	2" handle Bolt
5	1	V20021	Handle Washer
6	1	V20060	VALVE STEM THRUST BEARING
7	1	V20151M	BALL STEM FOR 1-1/2" & 2" VALVE
8	1	V20153SH	2" SHORT STYLE HANDLE
9	1	V20159	2" STEM BUSHING
10	1	V20163	AS568A -116 O-RING, FKM, BROWN
11	1	V20254	2" VALVE BODY
12	1	V20255A	2" Valve Ball
13	2	V20258A	2" Valve Seat
14	2	V20264	AS568A -151 O-RING, FKM, BROWN
15	1	VB20256	2" FEMALE COUPLER END PLATE
16	1	VF20256	2" MALE ADAPTER ENDPLATE, MACHINED

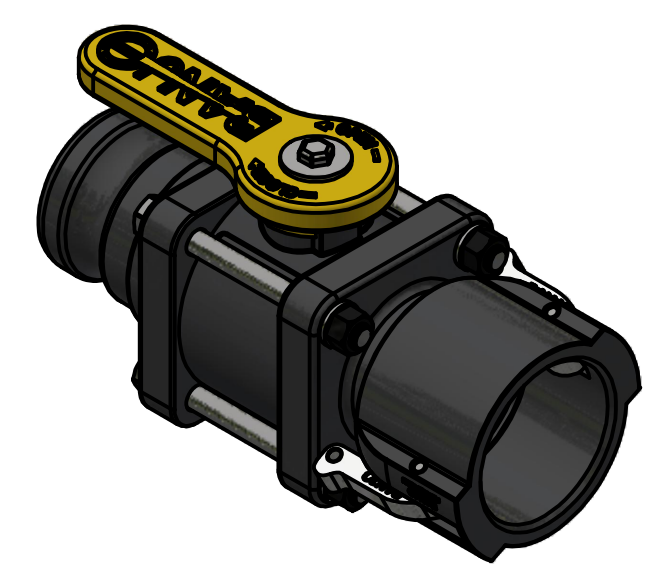

THIS DRAWING AND ALL INFORMATION CONTAINED THEREON ARE THE EXCLUSIVE PROPERTY OF BANJO CORPORATION.

UNLESS SPECIFICALLY NOTED, THIS DRAWING AND ITEMS SHOWN ON THIS DRAWING ARE SUBJECT TO CHANGE AT ANY TIME.

BANJO CORPORATION

150 BANJO DRIVE, CRAWFORDSVILLE, IN 47933
 WEB SITE: WWW.BANJOCORP.COM
 E-MAIL: BANJOSALES@IDEXCORP.COM

DESCRIPTION
2" FMLE X MALE COUPLER VALVE

PART NUMBER
VFB201