

PARTS LIST				
ITEM	QTY	PART NUMBER	DESCRIPTION	
1	1	A93M250V	2.50 MM x 93 MM ID METRIC O-RING, FKM, BROWN	
2	1	SB075100188T	SLEEVE BEARING PTFE 3/4 x 1 x 0.188	
3	4	V20010SS	3/8-16 X 2" HHCS	
4	4	V20018	3/8" LOCKWASHER	
5	4	V20019	3/8-16 HEX NUT	
6	1	V20020	2" handle Bolt	
7	1	V20021	Handle Washer	
8	1	V20060	VALVE STEM THRUST BEARING	
9	1	V20163	AS568A -116 O-RING, FKM, BROWN	
10	1	VFT25254	2" FP STUBBY FNPT BODY, FINAL MACHINE PROCESS	
11	1	VS20151	2" STUBBY VALVE STEM	
12	1	VS25153	2" FP STUBBY HANDLE	
13	1	VS25255	2" Stubby Full Port Ball	
14	2	VS25258AR1	2" FP BALL SEAT	
15	1	VS25356	2" FP STUBBY ENDPLATE, MACHINED	

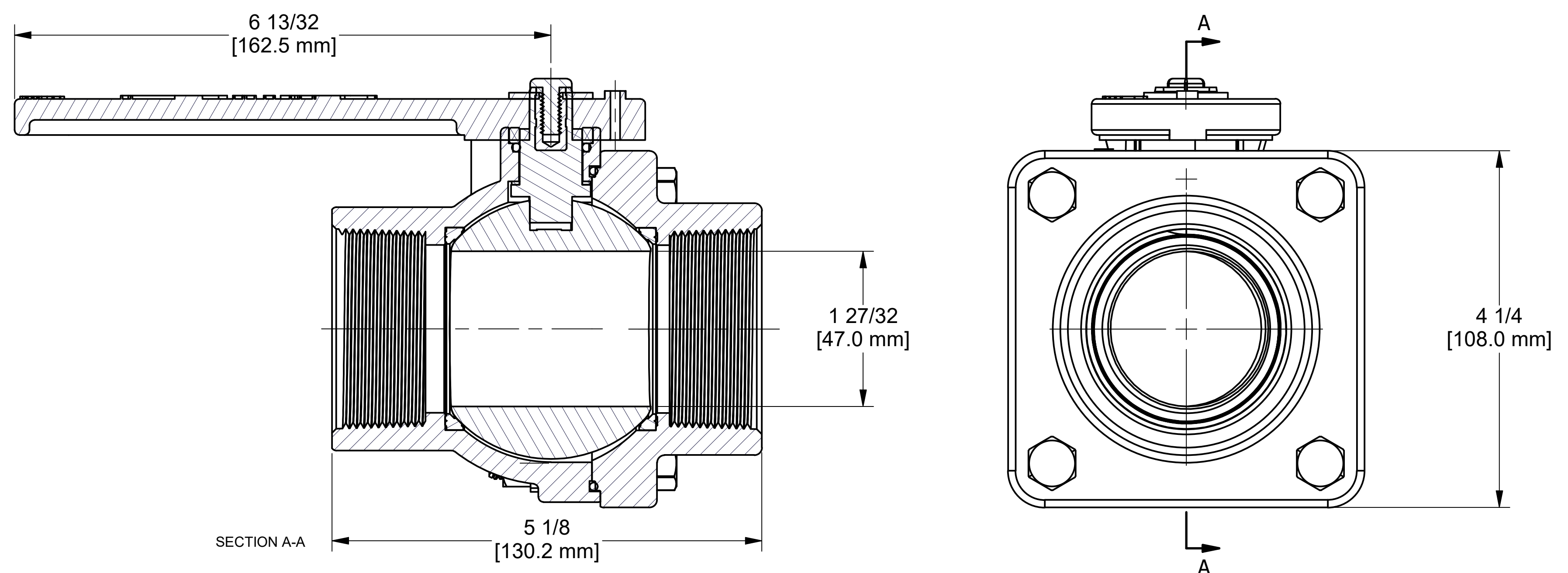
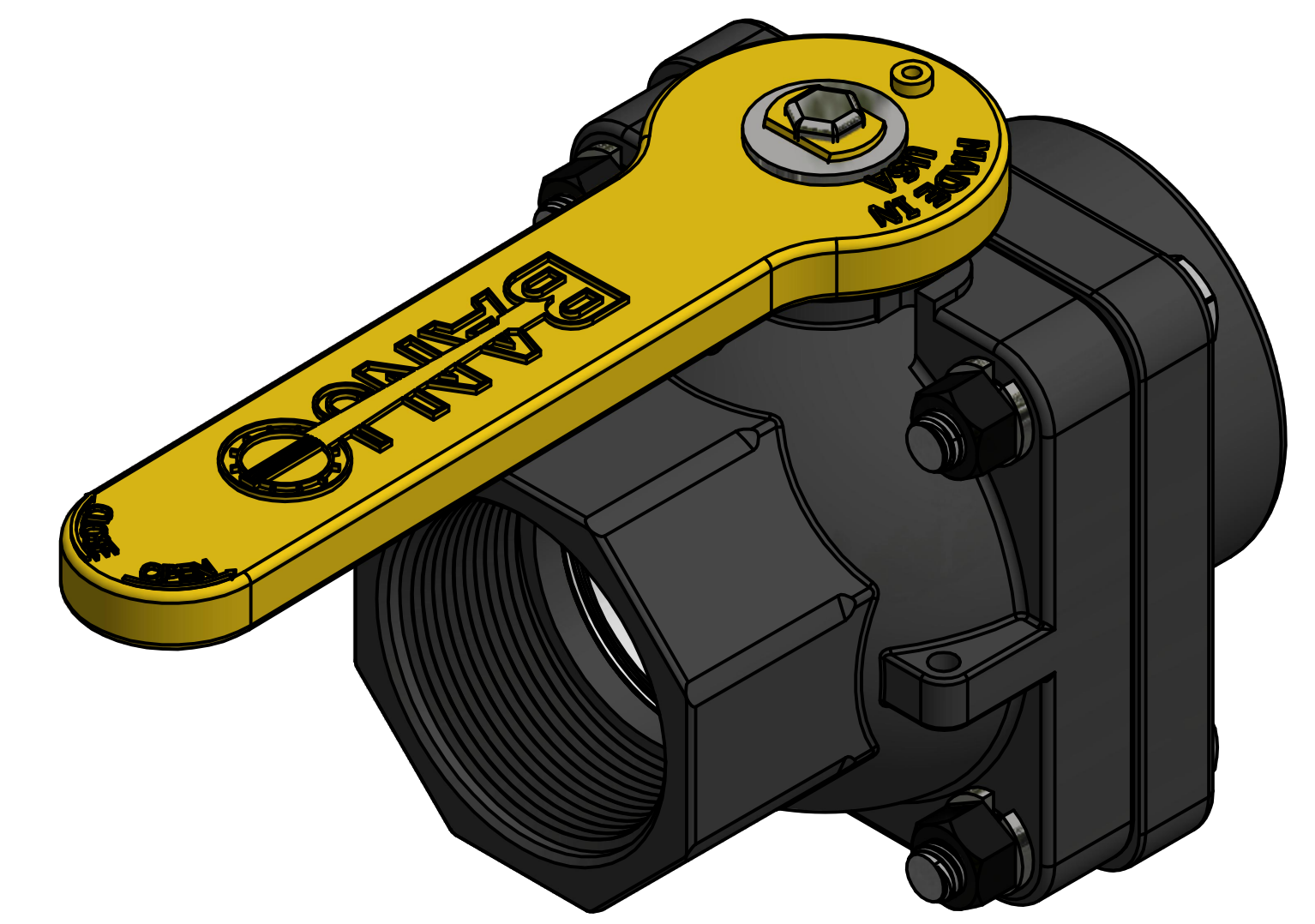

THIS DRAWING AND ALL INFORMATION CONTAINED THEREON ARE THE EXCLUSIVE PROPERTY OF BANJO CORPORATION.

UNLESS SPECIFICALLY NOTED, THIS DRAWING AND ITEMS SHOWN ON THIS DRAWING ARE SUBJECT TO CHANGE AT ANY TIME.

BANJO CORPORATION
 150 BANJO DRIVE, CRAWFORDSVILLE, IN 47933
 WEB SITE: WWW.BANJO.CORP.COM
 E-MAIL: BANJOSALES@IDEXCORP.COM

DESCRIPTION
 2" x 2" FEMALE NPT THREAD

PART NUMBER
 VS204FP