

PARTS LIST			
ITEM	QTY	PART NUMBER	DESCRIPTION
1	2	19766	3/8" FLAT WASHER
2	2	B038250	3/8-16 X 2 1/2" HHCS, ALL THD
3	1	H25053	2"-3" CARRY HANDLE
4	4	V20010SS	3/8-16 X 2" HHCS
5	6	V20018	3/8" LOCKWASHER
6	6	V20019	3/8" HEX NUT
7	1	V25020	3/8" Handle Bolt
8	1	V25121	3/8" Fender Washer
9	1	V25153	2" FP HANDLE
10	1	V25160	Stem Bushing
11	1	V25163	AS568A -214 O-RING, FKM, BROWN
12	1	V30151B	STEM 3" & 4" STUBBY, MACHINED
13	1	V35255C	3" FP BALL, TUMBLED
14	1	V35265	AS568A -160 O-RING, FKM, BROWN
15	2	VS35258	3" FP Stubby Valve Seat
16	1	VSB35356	3" FP STBY FML CPLR EP
17	1	VSHB35254	3" FP STUBBY HB BODY, MACHINED

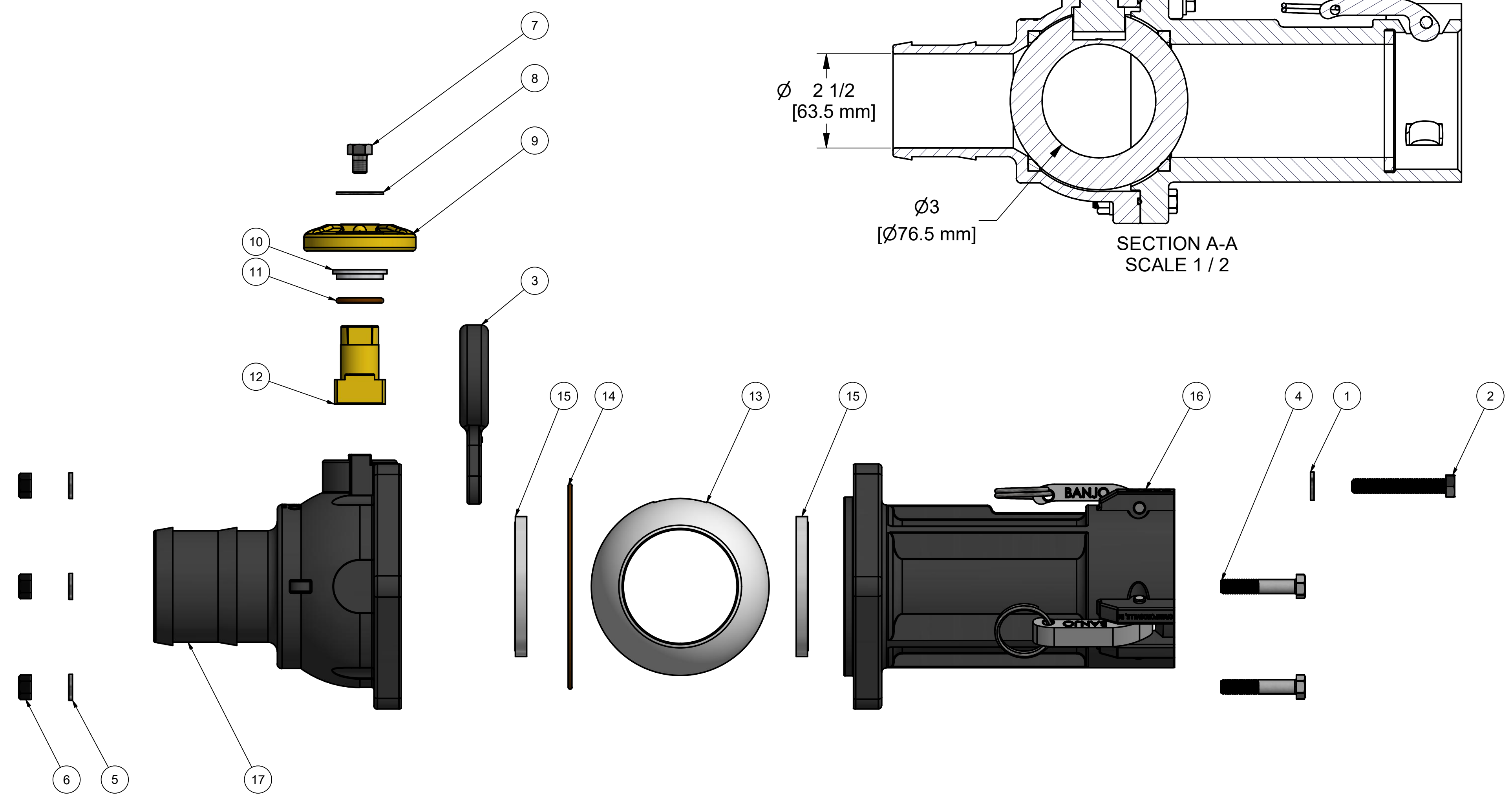
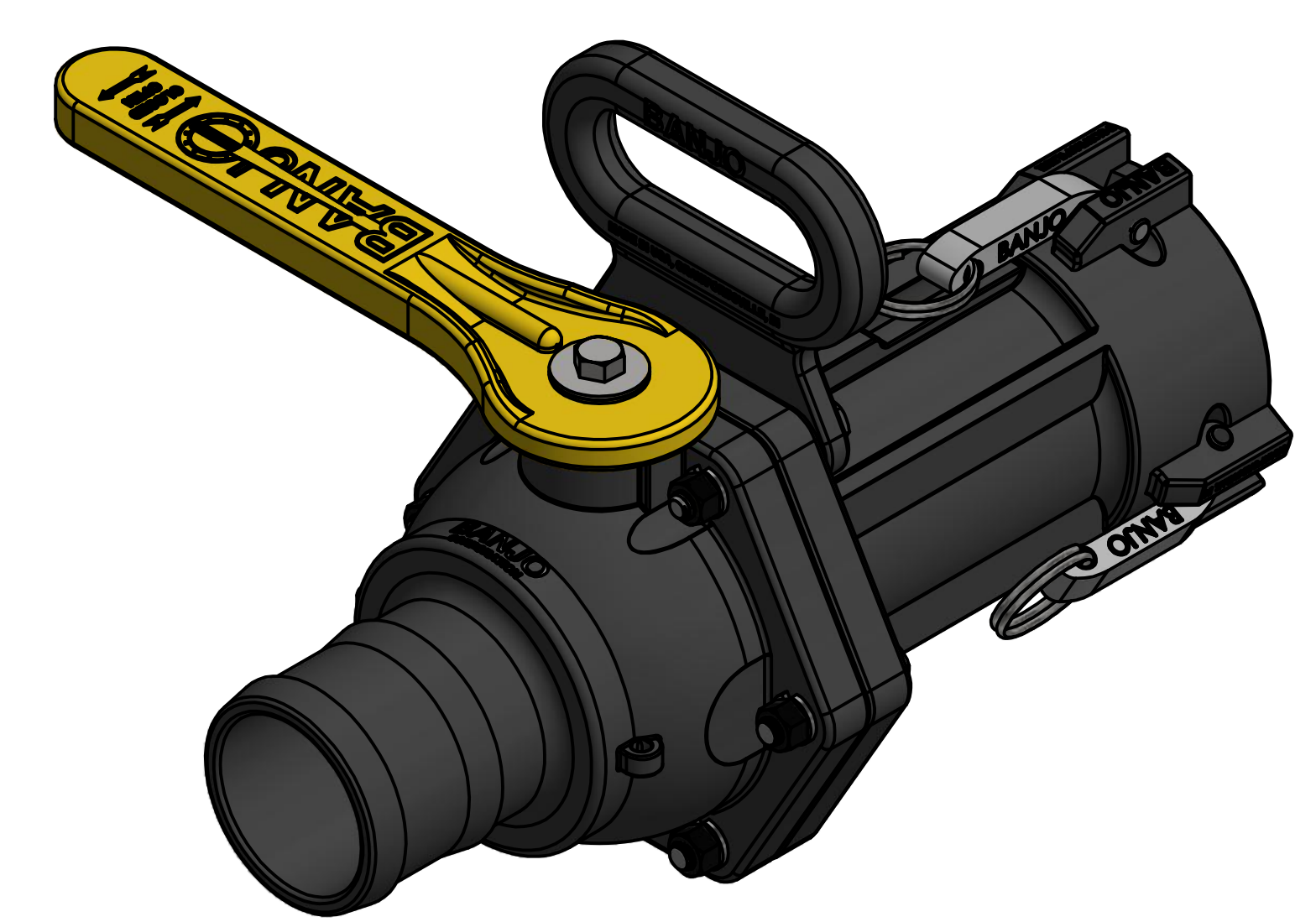

THIS DRAWING AND ALL INFORMATION CONTAINED THEREON ARE THE EXCLUSIVE PROPERTY OF BANJO CORPORATION.

UNLESS SPECIFICALLY NOTED, THIS DRAWING AND ITEMS SHOWN ON THIS DRAWING ARE SUBJECT TO CHANGE AT ANY TIME.

BANJO CORPORATION
 150 BANJO DRIVE, CRAWFORDSVILLE, IN 47933
 WEB SITE: WWW.BANJO.CORP.COM
 E-MAIL: BANJOSALES@IDEXCORP.COM

DESCRIPTION
3" HOSE SHANK x 3" FEMALE COUPLER STUBBY VALVE W/ CARRY HANDLE

PART NUMBER
VSBHB305FP