

PARTS LIST			
ITEM	QTY	PART NUMBER	DESCRIPTION
1	4	V20010SS	3/8-16 X 2" HHCS
2	4	V20018	3/8" LOCKWASHER
3	4	V20019	3/8-16 HEX NUT
4	1	V20020	2" handle Bolt
5	1	V20021	Handle Washer
6	2	V20060	VALVE STEM THRUST BEARING
7	1	V21204	TFE E/P BODY GASKET
8	1	VF22254Y	2" STUBBY VLV BDY MALE CPLR, MACH, w/o STEM SLOT CHAMFER
9	1	VS20151	2" STUBBY VALVE STEM
10	1	VS20152SH	2" STUBBY HANDLE
11	1	VS20255	2" STD PORT BALL, TUMBLED
12	1	VS20256B	2" BSPC END PLATE, MACHINED
13	1	VS20258A	BALL SEAT
14	1	WS20258	1 1/2" WELD VALVE SEAT

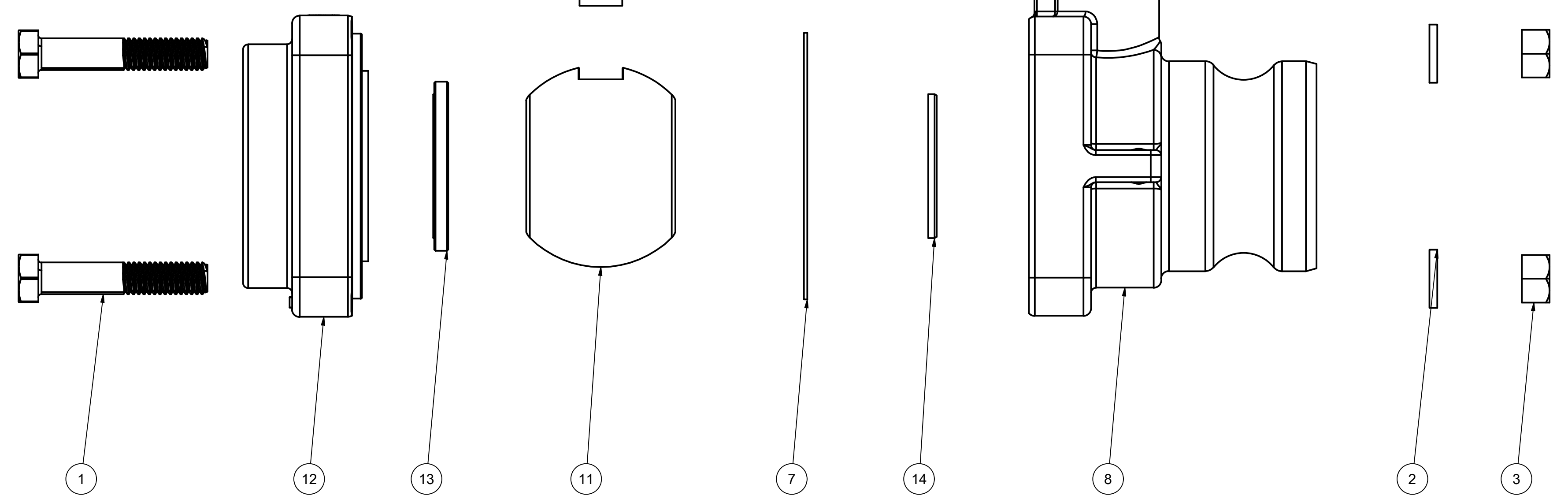
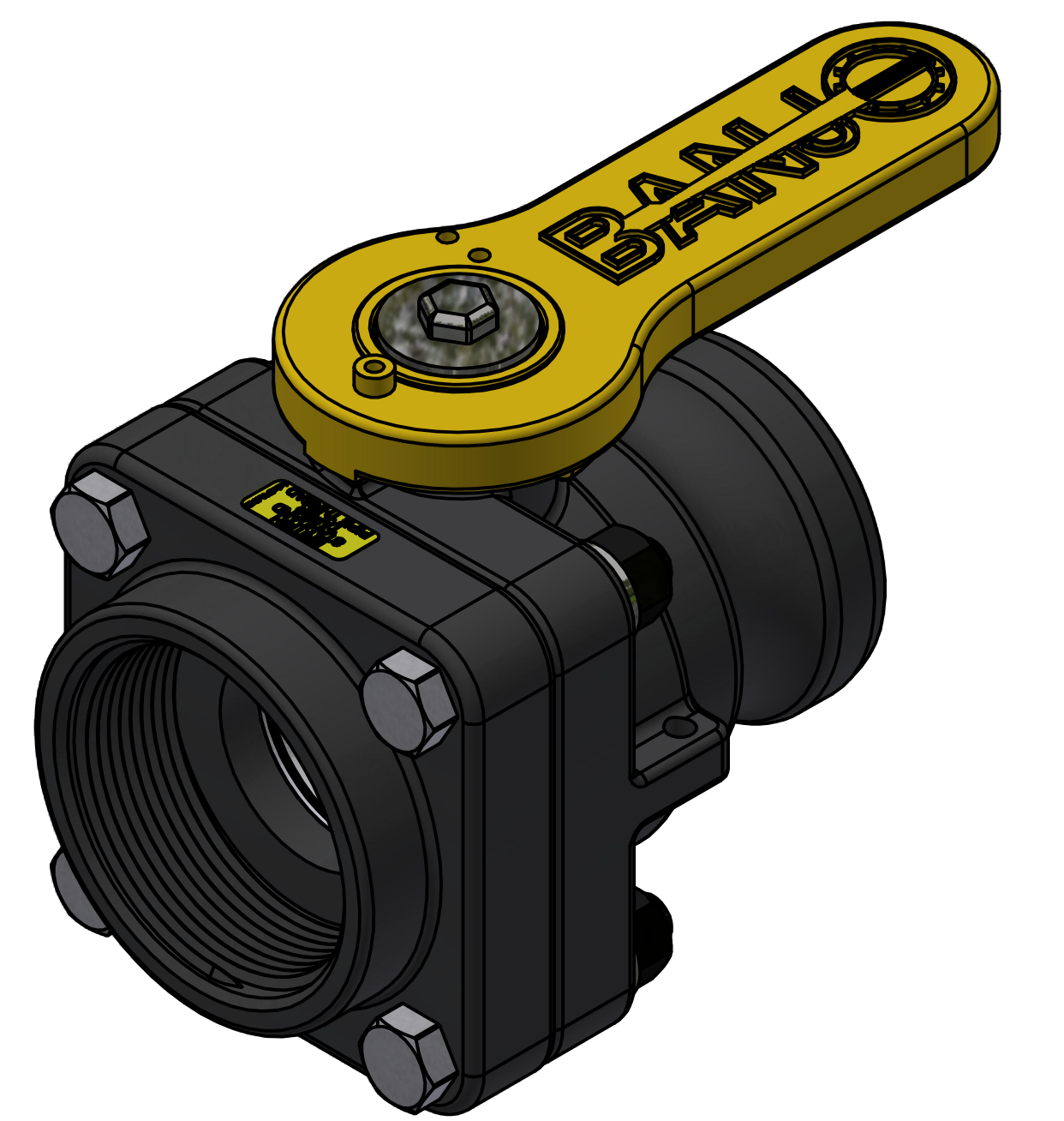
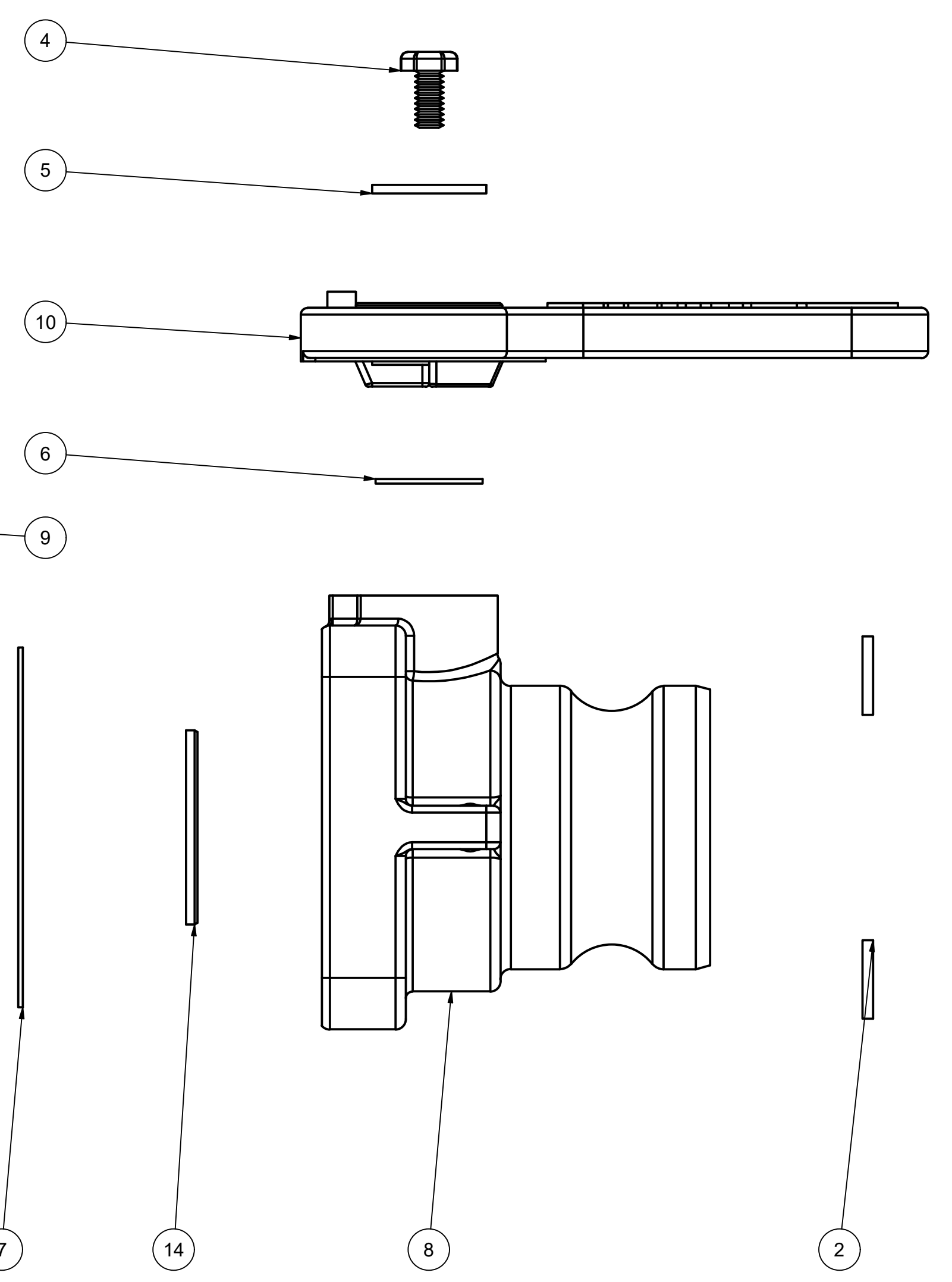

THIS DRAWING AND ALL INFORMATION CONTAINED THEREON ARE THE EXCLUSIVE PROPERTY OF BANJO CORPORATION.

UNLESS SPECIFICALLY NOTED, THIS DRAWING AND ITEMS SHOWN ON THIS DRAWING ARE SUBJECT TO CHANGE AT ANY TIME.

BANJO CORPORATION  
 150 BANJO DRIVE, CRAWFORDSVILLE, IN 47933  
 WEB SITE: WWW.BANJO.CORP.COM  
 E-MAIL: BANJOSALES@IDEXCORP.COM

DESCRIPTION  
**2" SHORT VALVE MALE ADPT-BSP**

PART NUMBER  
**VSF200B**