

SECTION C-C
SCALE 1:1

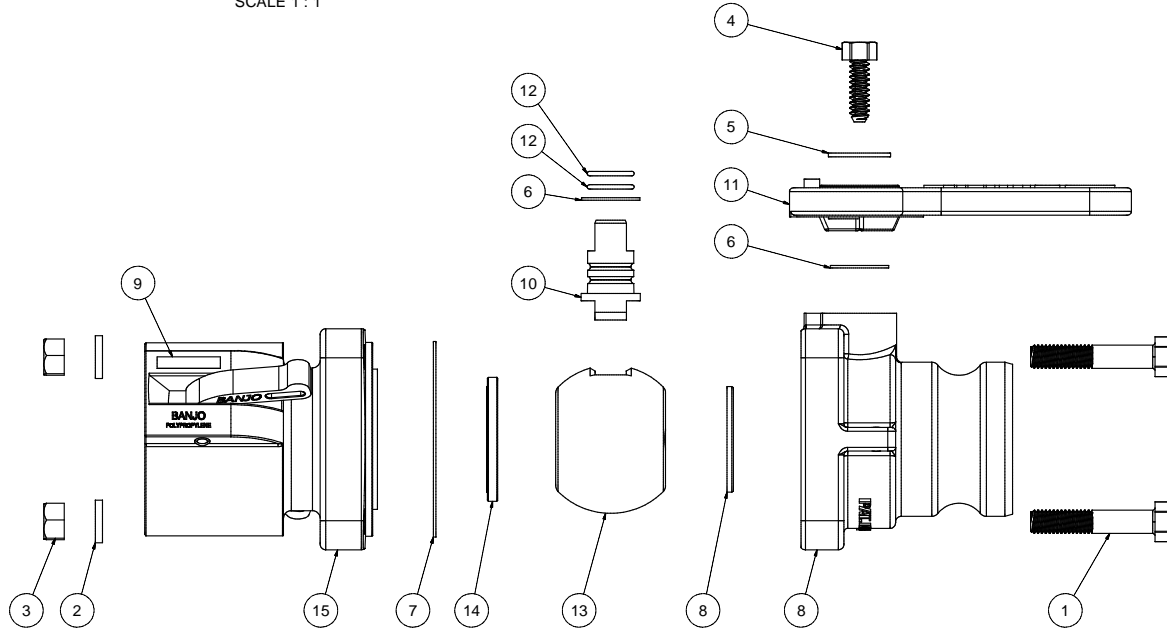

Parts List				
ITEM	QTY	PART NUMBER	DESCRIPTION	
1	4	V20010SS	3/8-16 X 2" HHCS	
2	4	V20018	3/8" LOCKWASHER	
3	4	V20019	3/8" HEX NUT	
4	1	V20020A	5/16-9 X 1" TRI-LOBULAR BOLT	
5	1	V20021A	HANDLE WASHER	
6	2	V20060	VALVE STEM THRUST BEARING	
7	1	V21204	TFE E/P BODY GASKET	
8	1	VF22254	2" F STUBBY BODY	
9	1	VL1005	VITON LABEL	
10	1	VS20151C	2" VALVE STEM	
11	1	VS20152SH	2" STUBBY HANDLE	
12	2	VS20163	#16 O-RING	
13	1	VS20255	2" VALVE BALL	
14	1	VS20258A	BALL SEAT	
15	1	VSB20256	2" B ENDPLATE	

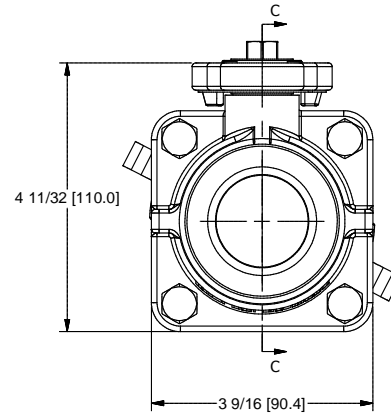
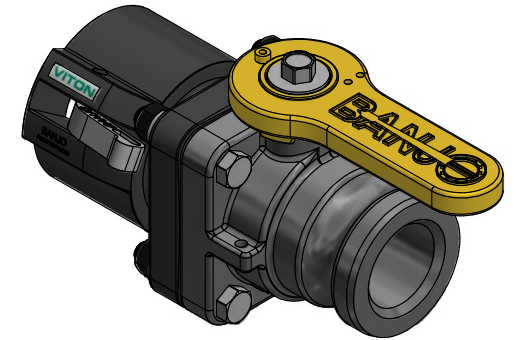

BANJO CORPORATION
150 BANJO DRIVE, CRAWFORDSVILLE, IN 47933
WEB SITE: WWW.BANJOCORP.COM
E-MAIL: BANJOSALES@IDEXCORP.COM

THIS DRAWING AND ALL INFORMATION CONTAINED THEREON ARE THE EXCLUSIVE PROPERTY OF BANJO CORPORATION.

UNLESS SPECIFICALLY NOTED, THIS DRAWING AND ITEMS SHOWN ON THIS DRAWING ARE SUBJECT TO CHANGE AT ANY TIME.

DESCRIPTION

2" VALVE W/ "F" ADAPTER

PART NUMBER

VSBF201V