

SECTION A-A
SCALE 1 : 1

PARTS LIST			
ITEM	QTY	PART NUMBER	DESCRIPTION
1	1	A93M250V	2.50 MM x 93 MM ID METRIC O-RING, FKM, BROWN
2	1	SB075100188T	SLEEVE BEARING PTFE 3/4 x 1 x 0.188
3	4	V20010SS	3/8-16 X 2" HHCS
4	4	V20018	3/8" LOCKWASHER
5	4	V20019	3/8-16 HEX NUT
6	1	V20020	2" handle Bolt
7	1	V20021	Handle Washer
8	1	V20060	VALVE STEM THRUST BEARING
9	1	V20163	AS568A -116 O-RING, FKM, BROWN
10	1	VF25254	2" FP MALE ADAPTER STUBBY BODY, MACHINED
11	1	VS20151	2" STUBBY VALVE STEM
12	1	VS25153	2" FP STUBBY HANDLE
13	1	VS25255	2" Stubby Full Port Ball
14	2	VS25258AR1	2" FP BALL SEAT
15	1	VSMT25356	2" FP 4-BOLT MALE THREAD ENDPLATE

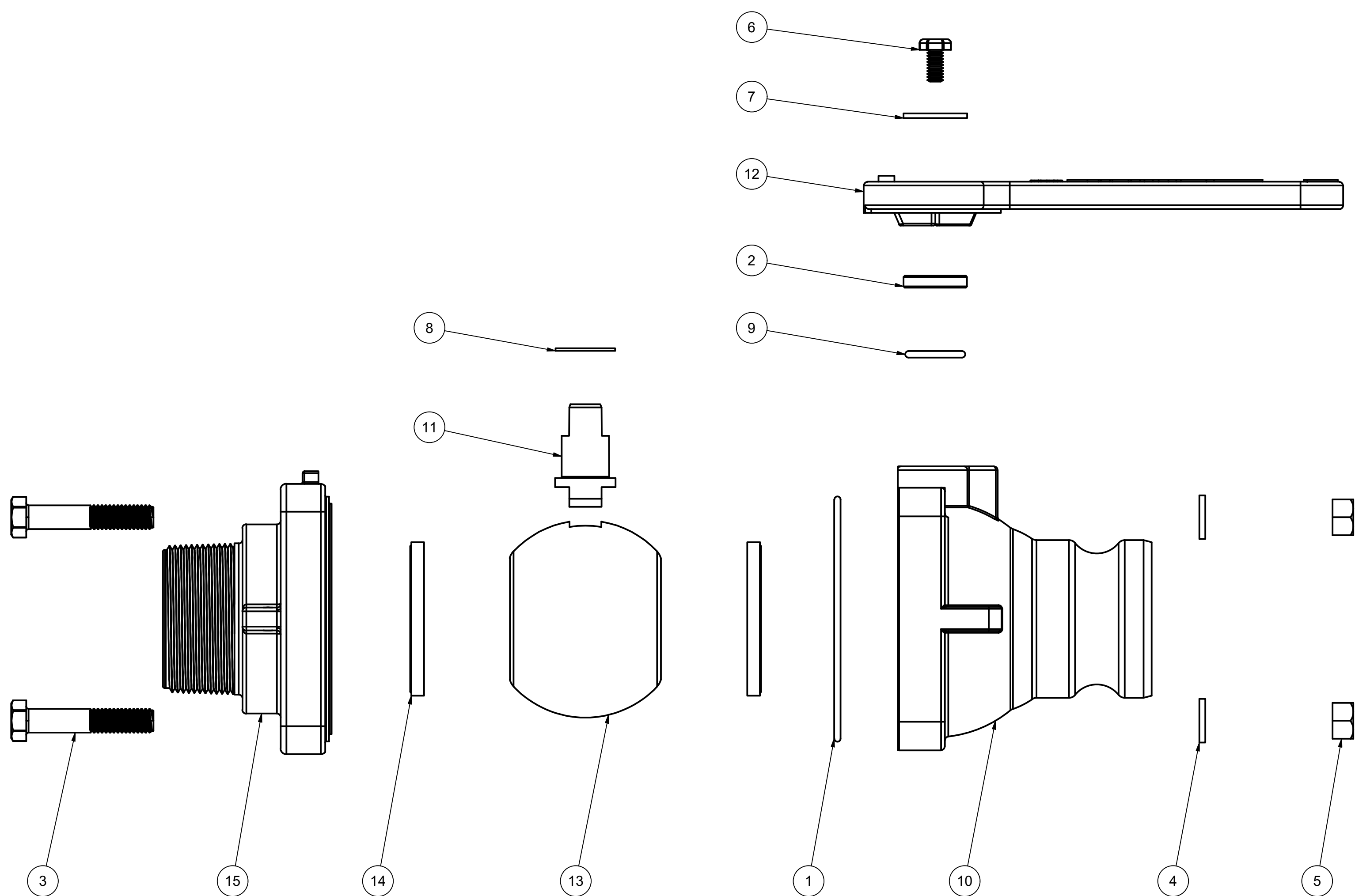

THIS DRAWING AND ALL INFORMATION CONTAINED THEREON ARE THE EXCLUSIVE PROPERTY OF BANJO CORPORATION.
UNLESS SPECIFICALLY NOTED, THIS DRAWING AND ITEMS SHOWN ON THIS DRAWING ARE SUBJECT TO CHANGE AT ANY TIME.

BANJO CORPORATION
150 BANJO DRIVE, CRAWFORDSVILLE, IN 47933
WEB SITE: WWW.BANJO.CORP.COM
E-MAIL: BANJOSALES@IDEXCORP.COM

DESCRIPTION
2" FP VALVE MALE ADAPTER x MNPT

PART NUMBER
VSFMT204FP