

		Parts List	
ITEM	QTY	PART NUMBER	DESCRIPTION
1	6	V20010SS	3/8-16 X 2" HHCS
2	6	V20018	3/8" LOCKWASHER
3	6	V20019	3/8" HEX NUT
4	1	V25020	3/8" Handle Bolt
5	1	V25121	3/8" Fender Washer
6	1	V25153SH	2" FP HANDLE
7	1	V25160	Stem Bushing
8	1	V25163	#214 FKM O'RING
9	1	V30265	#156 FKM O'RING
10	1	VS25151B	2" FP Stubby Stem
11	1	VS30255	3" VALVE BALL
12	2	VSF30258	3" Stubby Valve Seat
13	1	VSF30264	3" Stubby F Endplate
14	1	VSMT30254	3" STUBBY VALVE BODY W/ MALE THREADS

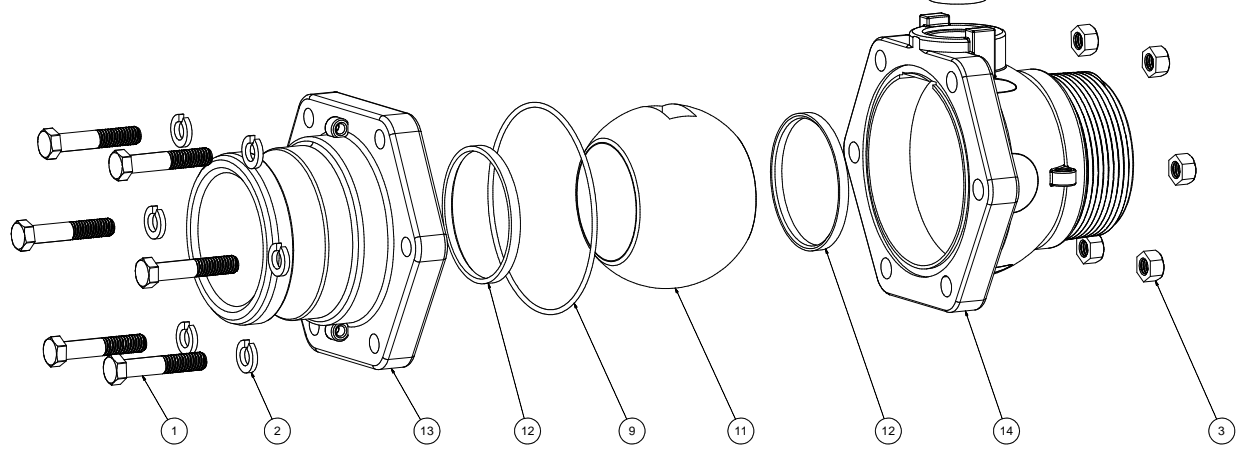
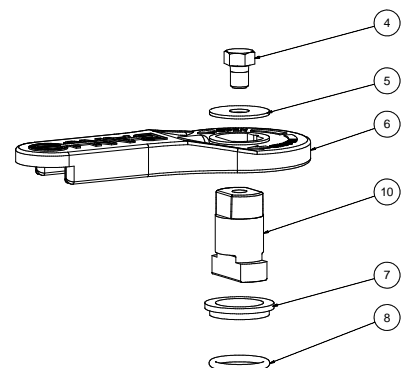
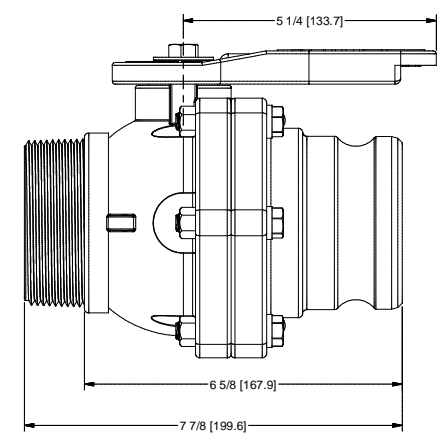
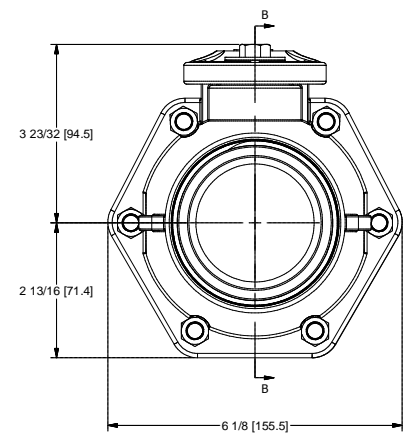
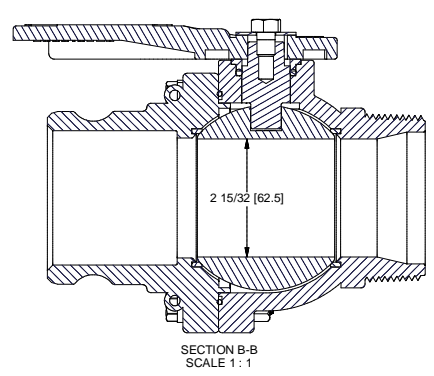

THIS DRAWING AND ALL INFORMATION CONTAINED THEREON ARE THE EXCLUSIVE PROPERTY OF BANJO CORPORATION.

BANJO CORPORATION
150 BANJO DRIVE, CRAWFORDSVILLE, IN 47933
WEB SITE: WWW.BANJOCORP.COM
E-MAIL: SALES1@BANJOCORP.COM

UNLESS SPECIFICALLY NOTED, THIS DRAWING AND ITEMS SHOWN ON THIS DRAWING ARE SUBJECT TO CHANGE AT ANY TIME.

DESCRIPTION: 3" M' STUBBY VALVE, SHORT HANDLE
PART NUMBER: VSFMT300SH