

SECTION A-A
SCALE 1 : 1

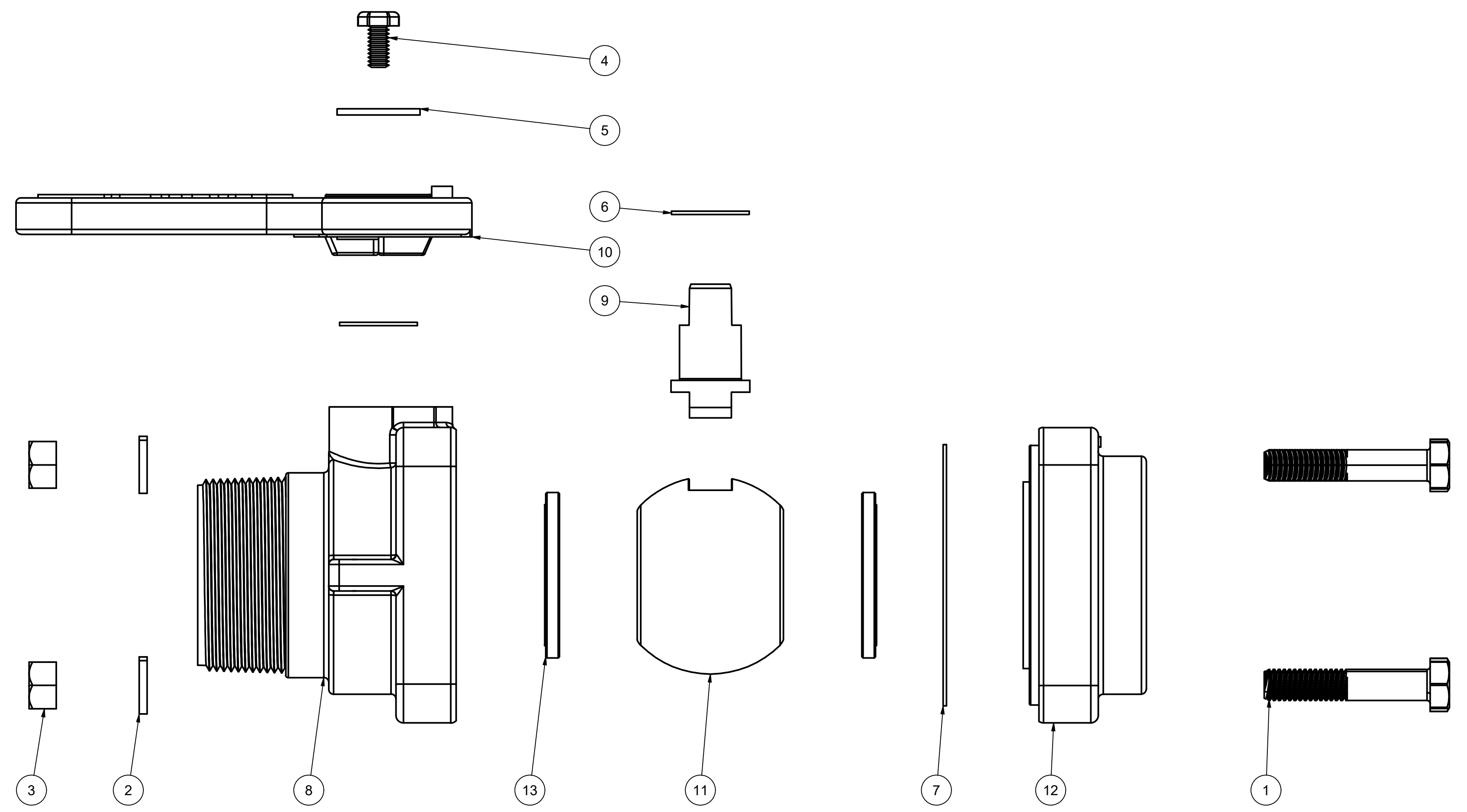

PARTS LIST			
ITEM	QTY	PART NUMBER	DESCRIPTION
1	4	V20010SS	3/8-16 X 2" HHCS
2	4	V20018	3/8" LOCKWASHER
3	4	V20019	3/8-16 HEX NUT
4	1	V20020	2" handle Bolt
5	1	V20021	Handle Washer
6	2	V20060	VALVE STEM THRUST BEARING
7	1	V21204	TFE E/P BODY GASKET
8	1	VMT20254	2" NPT STUBBY BODY, MACHINED
9	1	VS20151	2" STUBBY VALVE STEM
10	1	VS20152SH	2" STUBBY HANDLE
11	1	VS20255	2" STD PORT BALL, TUMBLED
12	1	VS20256	2" NPT STUBBY ENDPLATE, MACHINED
13	2	VS20258A	BALL SEAT

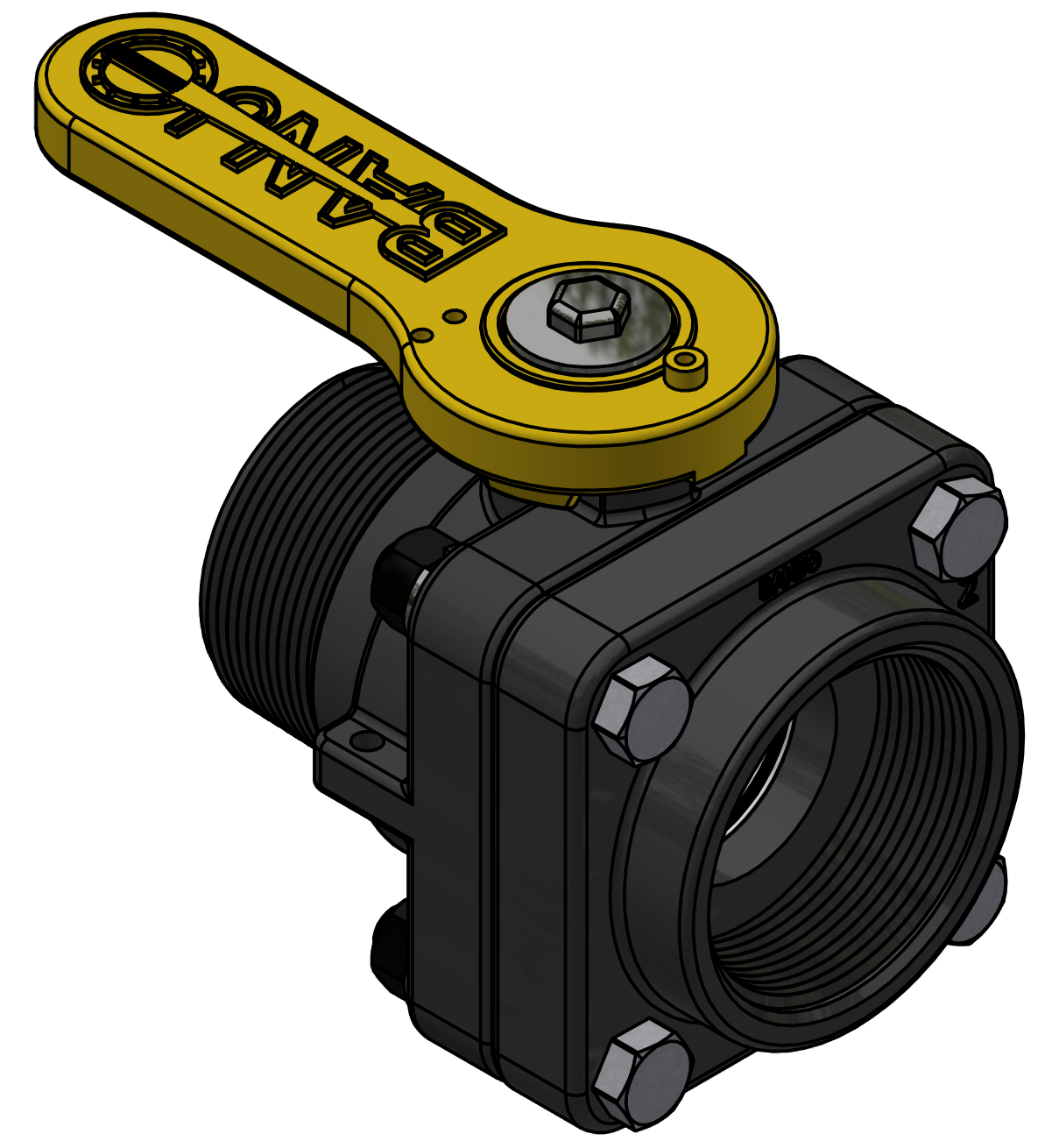

THIS DRAWING AND ALL INFORMATION CONTAINED THEREON ARE THE EXCLUSIVE PROPERTY OF BANJO CORPORATION.
UNLESS SPECIFICALLY NOTED, THIS DRAWING AND ITEMS SHOWN ON THIS DRAWING ARE SUBJECT TO CHANGE AT ANY TIME.

BANJO CORPORATION
150 BANJO DRIVE, CRAWFORDSVILLE, IN 47933
WEB SITE: WWW.BANJO.CORP.COM
E-MAIL: BANJOSALES@IDEXCORP.COM

DESCRIPTION
2" MALE NPT X 2" FEMALE NPT VLV

PART NUMBER
VSMT200