

Parts List			
ITEM	QTY	PART NUMBER	DESCRIPTION
1	6	V20010SS	3/8-16 X 2" HHCS
2	6	V20018	3/8" LOCKWASHER
3	6	V20019	3/8" HEX NUT
4	1	V25020	3/8" Handle Bolt
5	1	V25121	3/8" Fender Washer
6	1	V25153	2" FP Handle
7	1	V25160	Stem Bushing
8	1	V25163	#214 FKM O'RING
9	1	V30265	#156 FKM O'RING
10	1	VS25151B	2" FP Stubby Stem
11	1	VS30254	3" STUBBY BODY, 3" NPT
12	1	VS30255	3" VALVE BALL
13	2	VS30258	3" Stubby Valve Seat
14	1	VSMT30264	3" MNPT Stubby Endplate

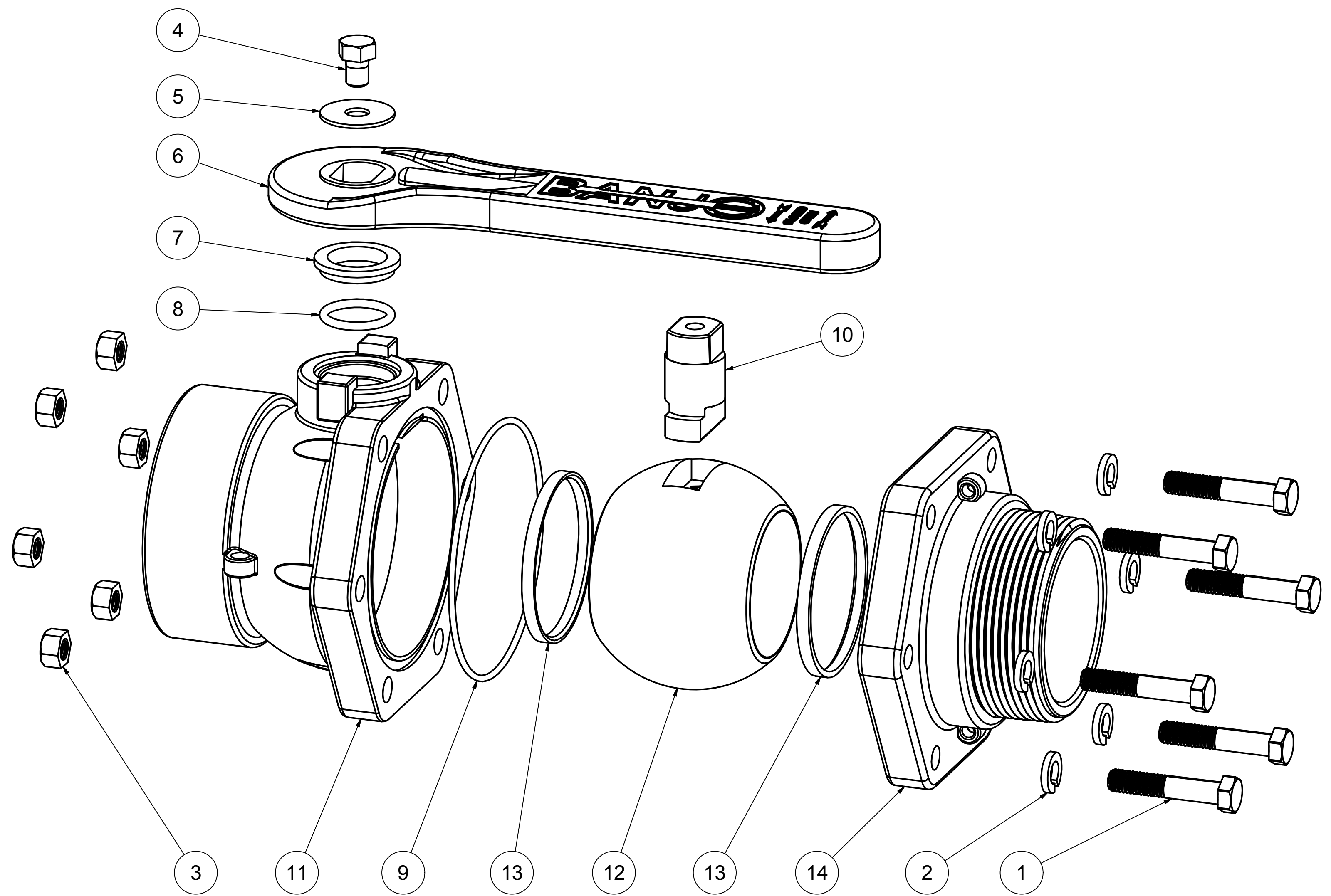

THIS DRAWING AND ALL INFORMATION CONTAINED THEREON ARE THE EXCLUSIVE PROPERTY OF BANJO CORPORATION.

UNLESS SPECIFICALLY NOTED, THIS DRAWING AND ITEMS SHOWN ON THIS DRAWING ARE SUBJECT TO CHANGE AT ANY TIME.



BANJO CORPORATION

150 BANJO DRIVE, CRAWFORDSVILLE, IN 47933
 WEB SITE: WWW.BANJOCORP.COM
 E-MAIL: SALES1@BANJOCORP.COM

DESCRIPTION	3" MNPT Stubby Valve, Long Handle
PART NUMBER	VSMT300