

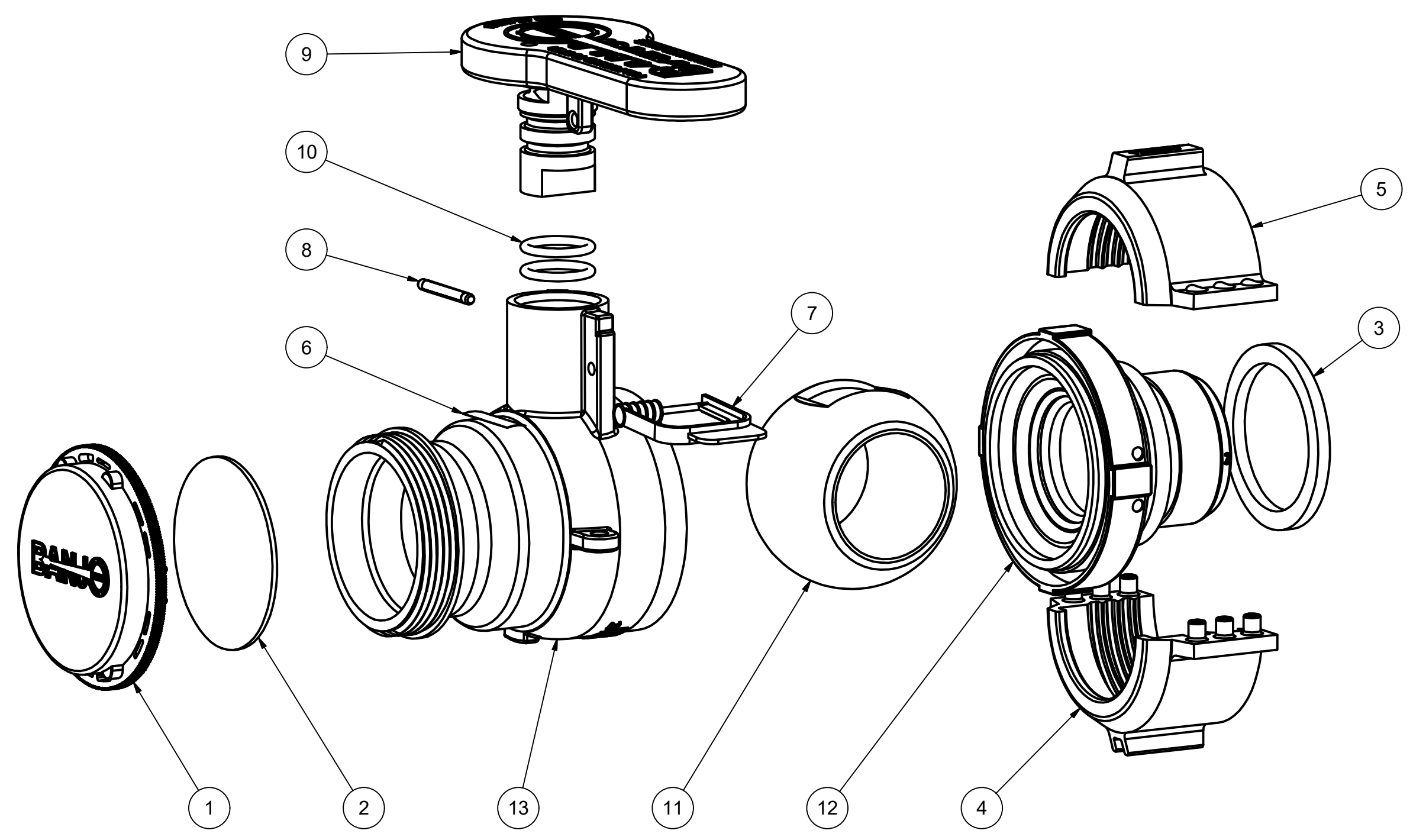

Parts List			
ITEM	QTY	PART NUMBER	DESCRIPTION
1	1	201FPTX	2" NPT BLACK Cap
2	1	202FPTG	12A White Volara 2.28 x 1/16
3	1	V22275G	VALVE GASKET
4	1	V22283C	MALE COLLAR HALF
5	1	V22283D	FEMALE COLLAR HALF
6	1	VL1004	EPDM DECAL
7	1	VS20209	SPRING-LOK SEAL
8	1	WS20002	Pin
9	1	WS20153	2" Handle for W Valve
10	2	WS20163E	#115 O'RING
11	1	WS20255T	2" TUMBLED VALVE BALL
12	1	WS22296	WELDED VALVE ENDPLATE
13	1	WSF20264	2" QDC WELD BODY

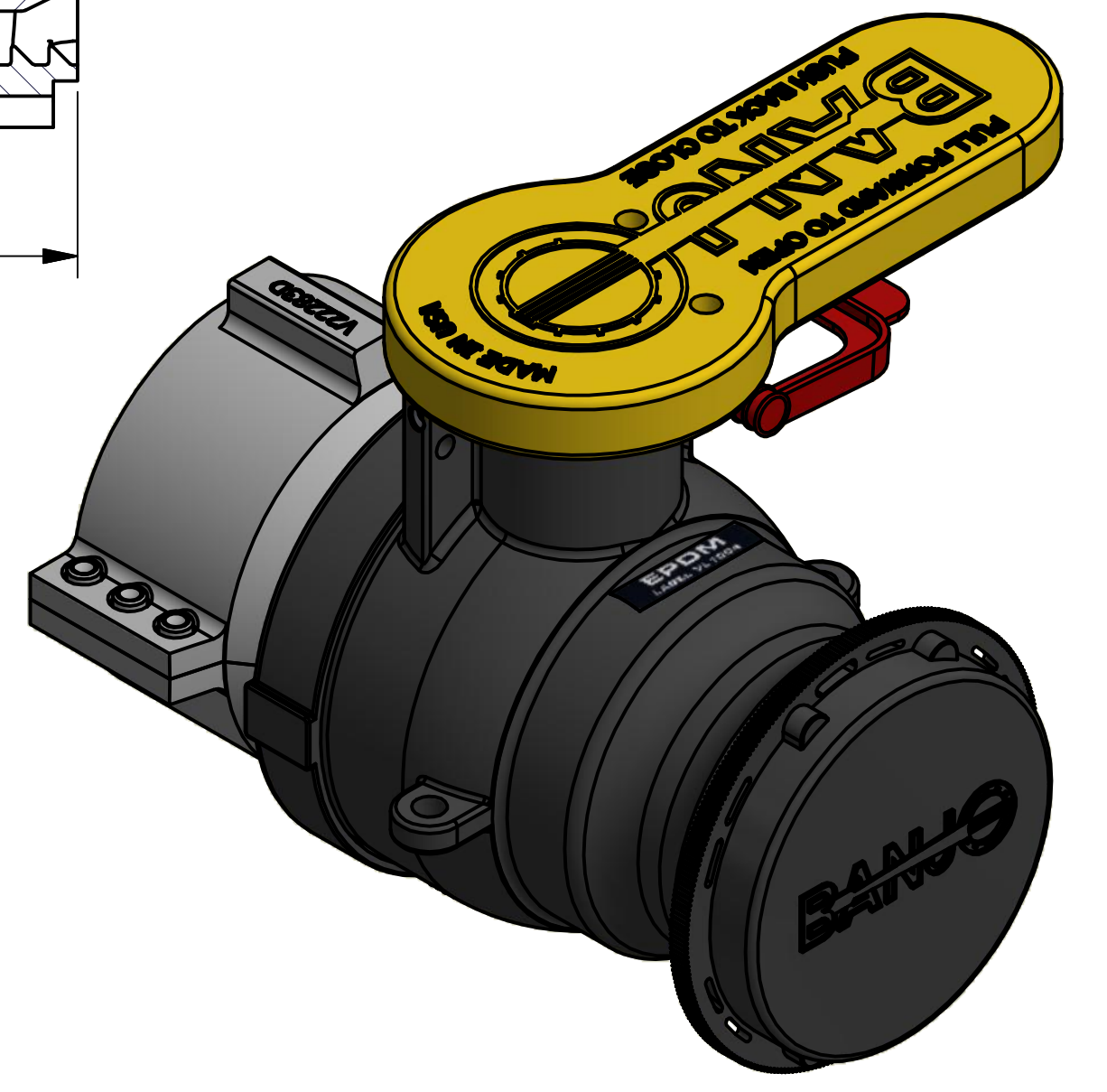

THIS DRAWING AND ALL INFORMATION CONTAINED THEREON ARE THE EXCLUSIVE PROPERTY OF BANJO CORPORATION.

UNLESS SPECIFICALLY NOTED, THIS DRAWING AND ITEMS SHOWN ON THIS DRAWING ARE SUBJECT TO CHANGE AT ANY TIME.



BANJO CORPORATION

150 BANJO DRIVE, CRAWFORDSVILLE, IN 47933
 WEB SITE: WWW.BANJOCORP.COM
 E-MAIL: BANJOSALES@IDEXCORP.COM

DESCRIPTION	MAUSER 2"POLY VLV QD EPDM WITH CAP
PART NUMBER	W230236

