

SECTION A-A
SCALE 1 : 1

PARTS LIST			
ITEM	QTY	PART NUMBER	DESCRIPTION
1	1	050DECAL	Banjo Logo Decal
2	1	201FPTX	2" NPT BLACK CAP
3	1	C25PFSLE113	Foil Seal 0.035" C25 FSLE 1-13 59mm
4	1	V20280A	METAL VALVE RING - MALE
5	1	V20280B	METAL RING HALF, FEMALE
6	1	VS20209	SPRING-LOK SEAL
7	1	W20284GS	2" TPV GASKET FOR 80 VALVES
8	1	WS20002	WELD VALVE RETAINING PIN, STEEL
9	1	WS20153	2" HANDLE FOR W VALVES
10	2	WS20163	AS568A -115 O-RING, FKM, BROWN
11	1	WS20255T	2" TUMBLED VALVE BALL
12	1	WS20284R1	NOTCHED 80 SERIES END PLATE
13	1	WSF20264	2" COMBINATION WELD VALVE BODY

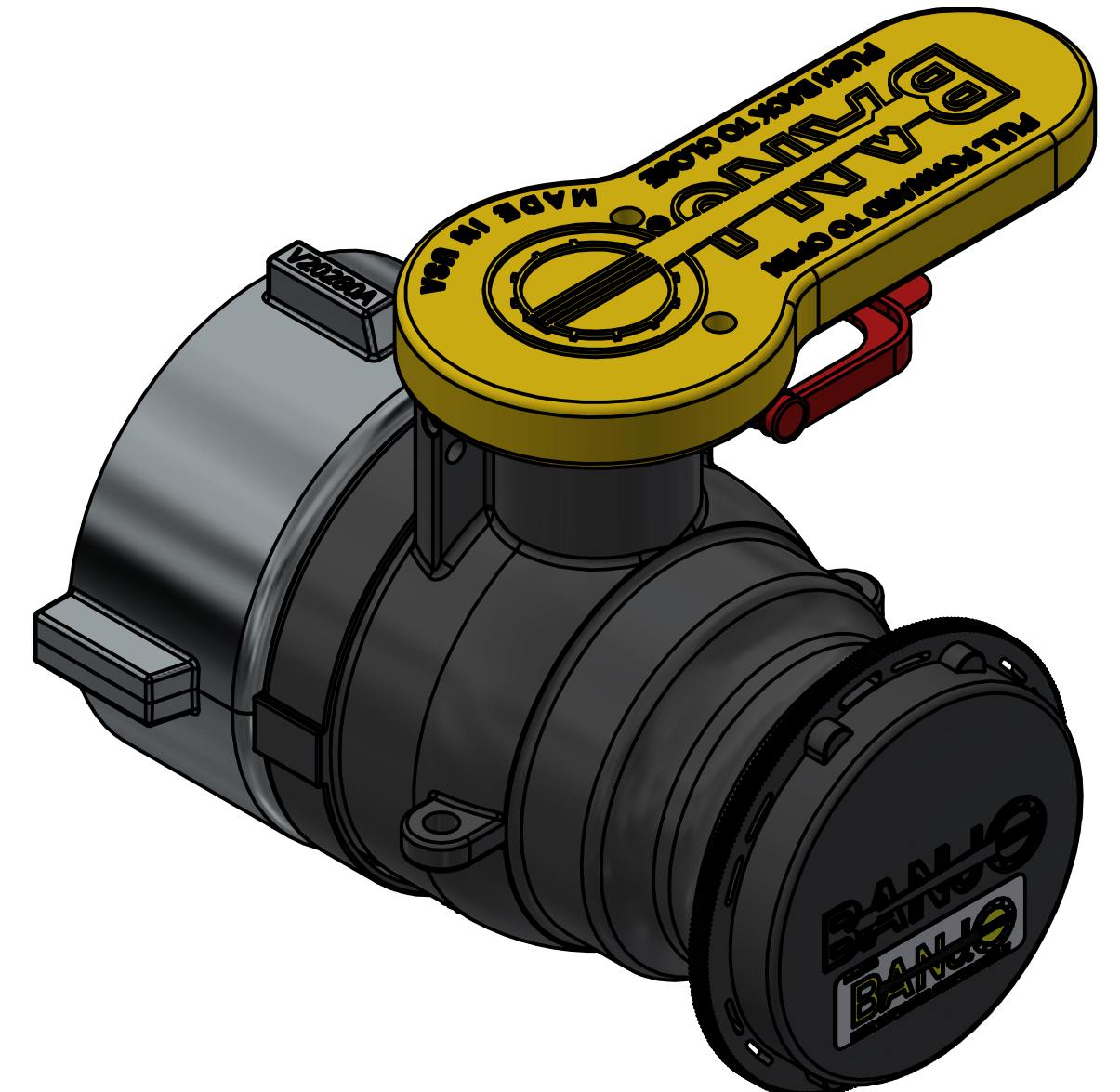
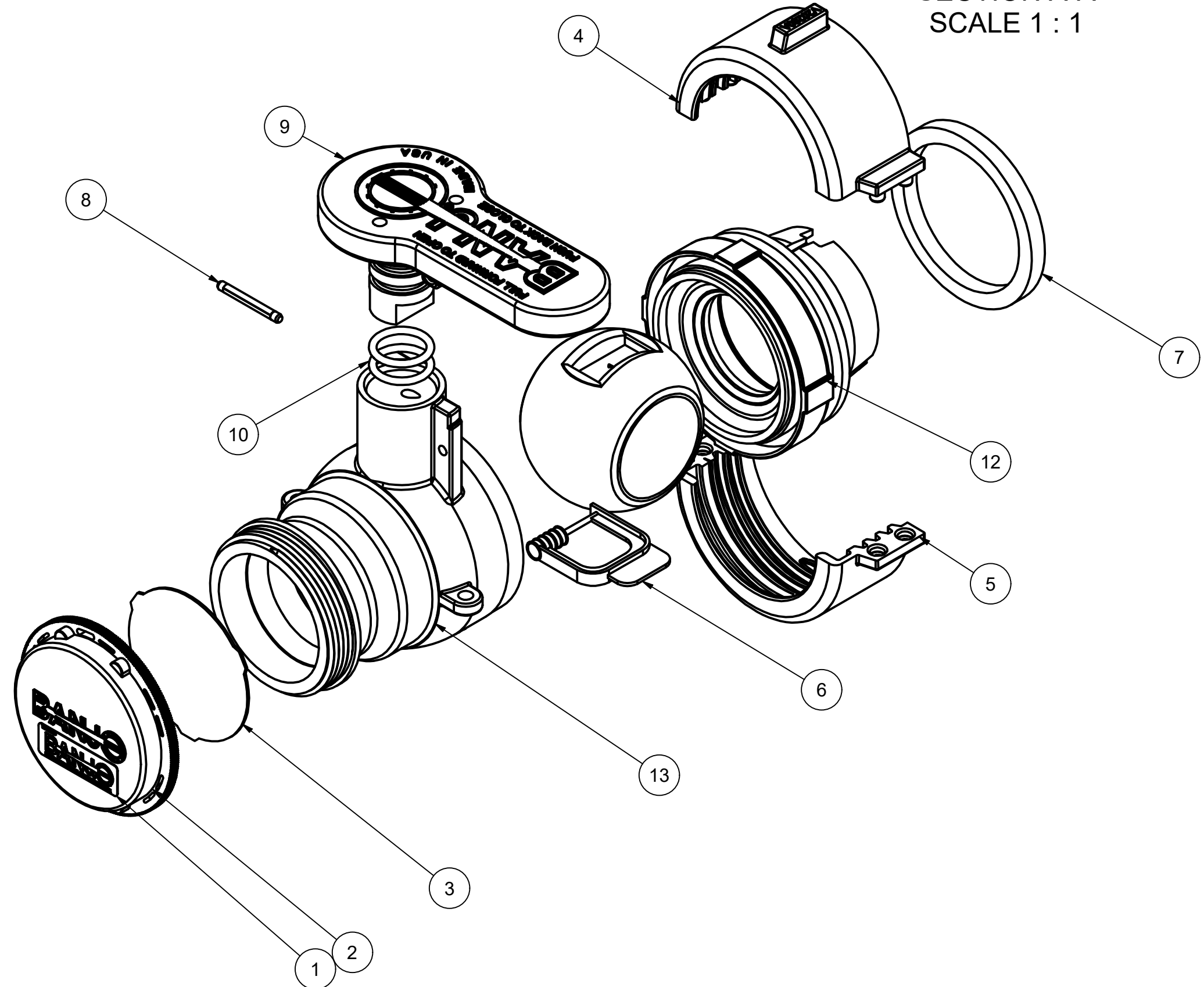

THIS DRAWING AND ALL INFORMATION CONTAINED THEREON ARE THE EXCLUSIVE PROPERTY OF BANJO CORPORATION.

UNLESS SPECIFICALLY NOTED, THIS DRAWING AND ITEMS SHOWN ON THIS DRAWING ARE SUBJECT TO CHANGE AT ANY TIME.

BANJO CORPORATION
150 BANJO DRIVE, CRAWFORDSVILLE, IN 47933
WEB SITE: WWW.BANJOCORP.COM
E-MAIL: BANJOSALES@IDEXCORP.COM

DESCRIPTION
SCHUTZ 2"QD ALIGNMENT VLV WITH SEAL

PART NUMBER
WSF210FSA