

Parts List			
ITEM	QTY	PART NUMBER	DESCRIPTION
1	1	050DECAL	Banjo Logo Decal
2	1	211FPTX	2" NPT Yellow Cap
3	1	C25PFSLE113	Foil Seal 0.035" C25 FSLE 1-13 59mm
4	1	V20280A	RING HALF, MALE
5	1	V20280B	RING HALF, FEMALE
6	1	VL1005	FKM LABEL
7	1	VS20209	SPRING-LOK SEAL
8	1	W20284GV	VALVE GASKET
9	1	WS20002	Pin
10	1	WS20153	2" Handle for W Valve
11	2	WS20163	2-115 O-ring, FKM
12	1	WS20255T	2" TUMBLED VALVE BALL
13	1	WS20284R1	NOTCHED 80 SERIES END PLATE
14	1	WSF20264	2" COMBINATION WELD VALVE BODY

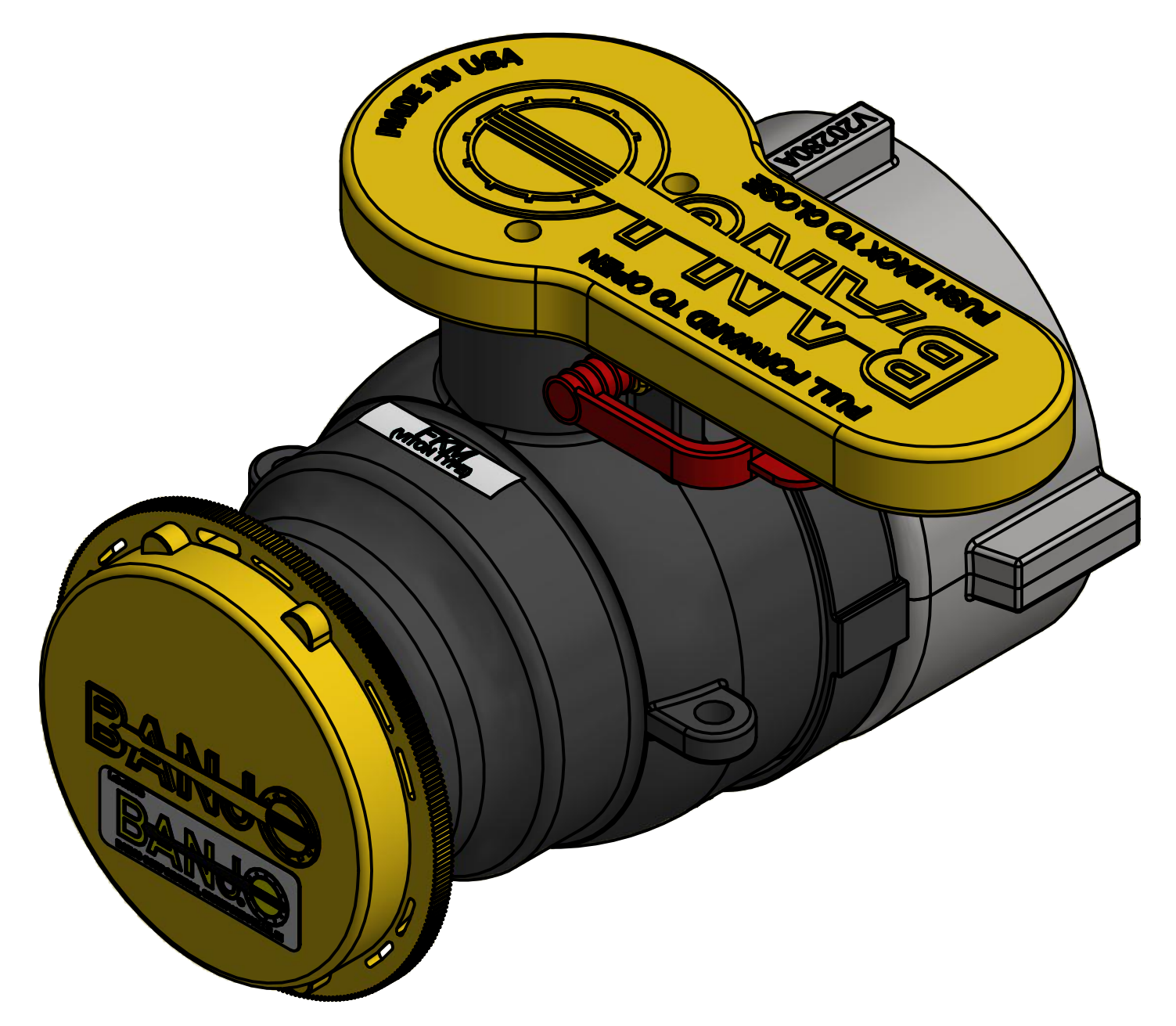

Welded valve. Individual parts shown not available for purchase.

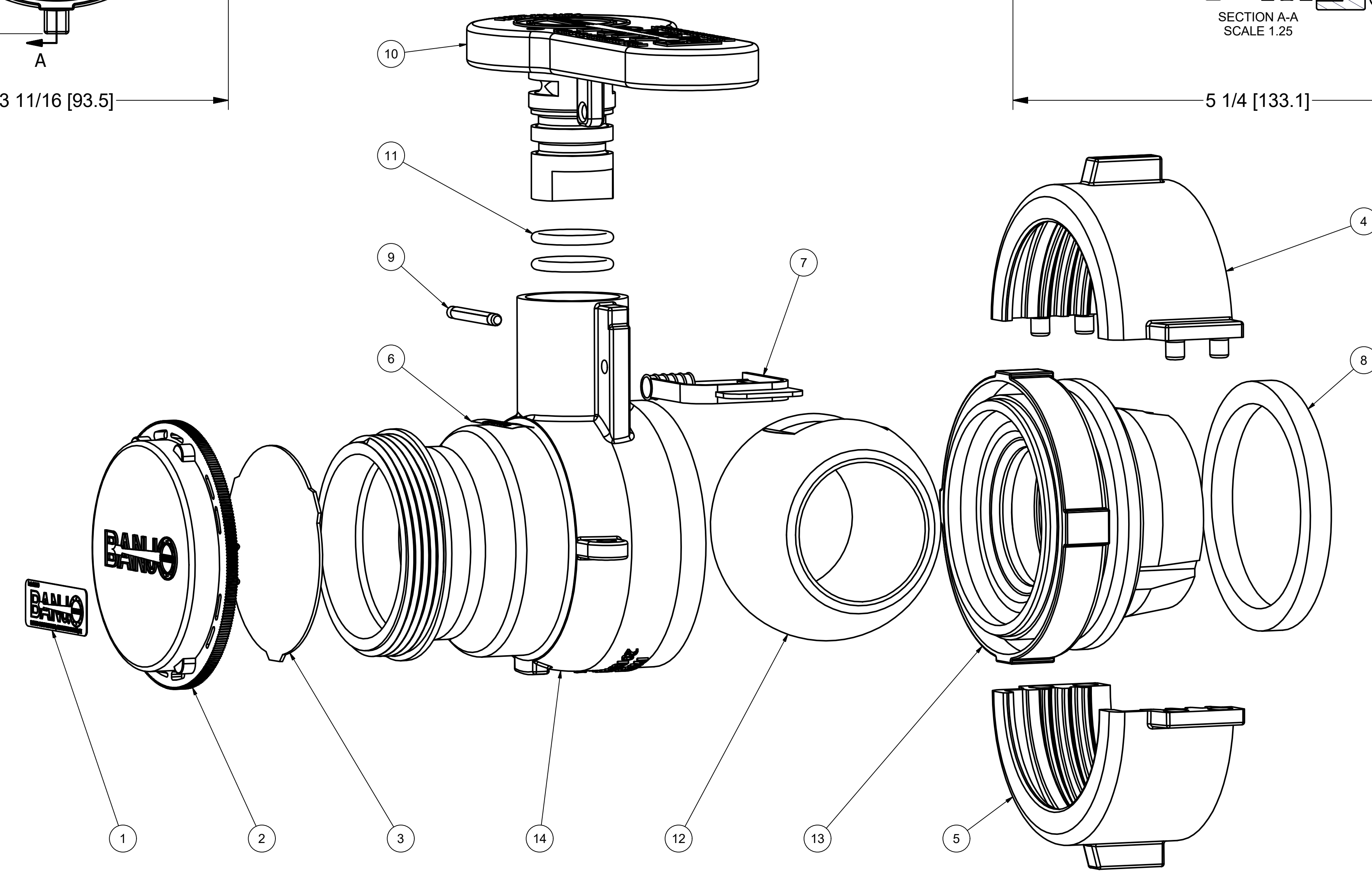

THIS DRAWING AND ALL INFORMATION CONTAINED THEREON ARE THE EXCLUSIVE PROPERTY OF BANJO CORPORATION.
UNLESS SPECIFICALLY NOTED, THIS DRAWING AND ITEMS SHOWN ON THIS DRAWING ARE SUBJECT TO CHANGE AT ANY TIME.

BANJO CORPORATION
150 BANJO DRIVE, CRAWFORDSVILLE, IN 47933
WEB SITE: WWW.BANJO.CORP.COM
E-MAIL: BANJOSALES@DEXCORP.COM
DESCRIPTION
SCHUTZ 2"QD ALIGNMENT VALVE W/SEAL
PART NUMBER
WSF210FSAV