

SECTION B-B  
SCALE 1 : 1

PARTS LIST			
ITEM	QTY	PART NUMBER	DESCRIPTION
1	1	050DECAL	Banjo Logo Decal
2	1	201FPTX	2" NPT BLACK CAP
3	1	C25PFSLE113	Foil Seal 0.035" C25 FSLE 1-13 59mm
4	1	V20280A	METAL VALVE RING - MALE
5	1	V20280B	METAL RING HALF, FEMALE
6	1	W20284GS	2" TPV GASKET FOR 80 VALVES
7	1	WS20002	WELD VALVE RETAINING PIN, STEEL
8	1	WS20153	2" HANDLE FOR W VALVES
9	2	WS20163	AS568A -115 O-RING, FKM, BROWN
10	1	WS20255T	2" TUMBLED VALVE BALL
11	1	WS20284R1	NOTCHED 80 SERIES END PLATE
12	1	WSMT20254	2" NPT WELD BODY, MACHINED

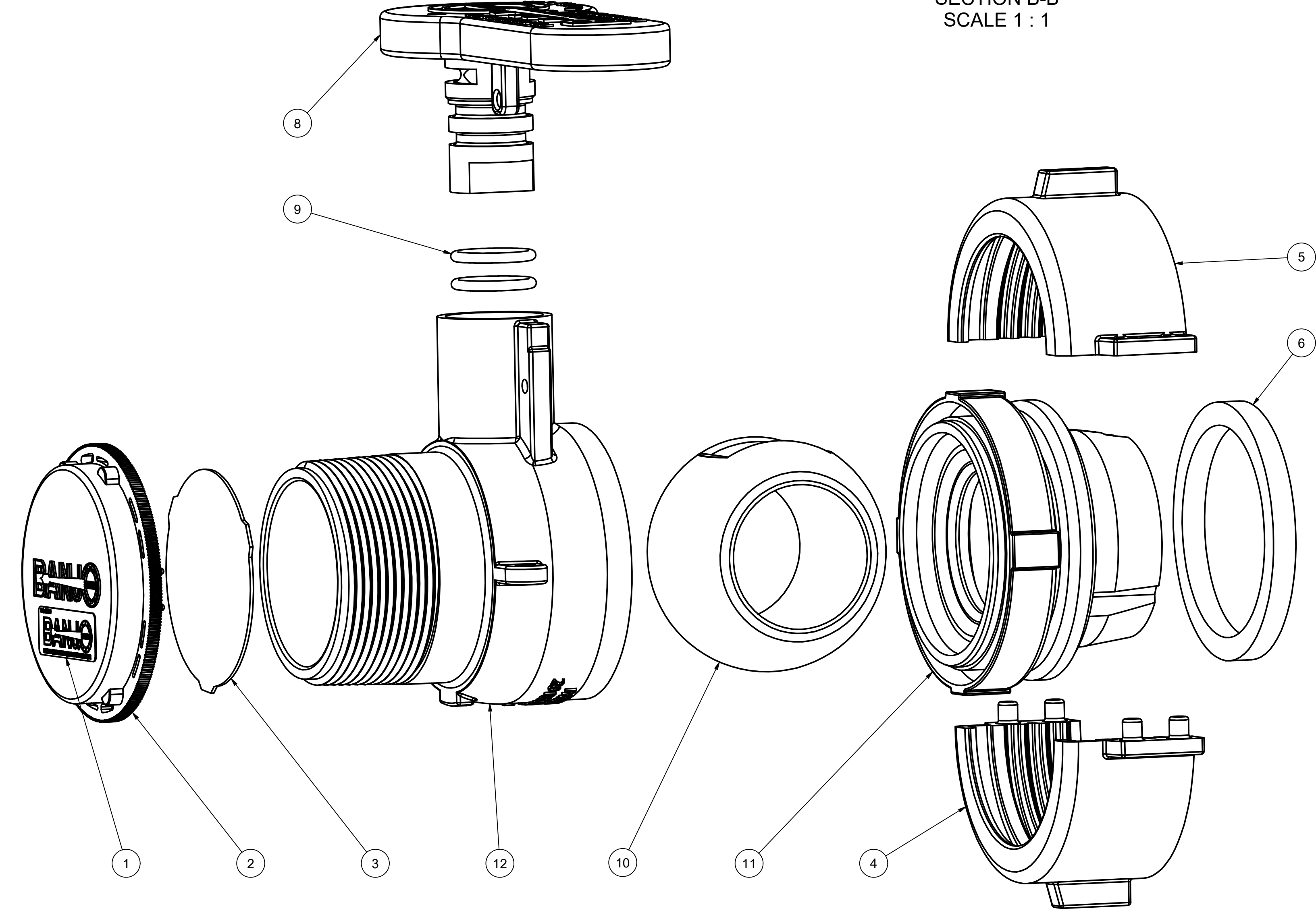

WELDED VALVE. INDIVIDUAL PARTS SHOWN NOT AVAILABLE FOR PURCHASE.

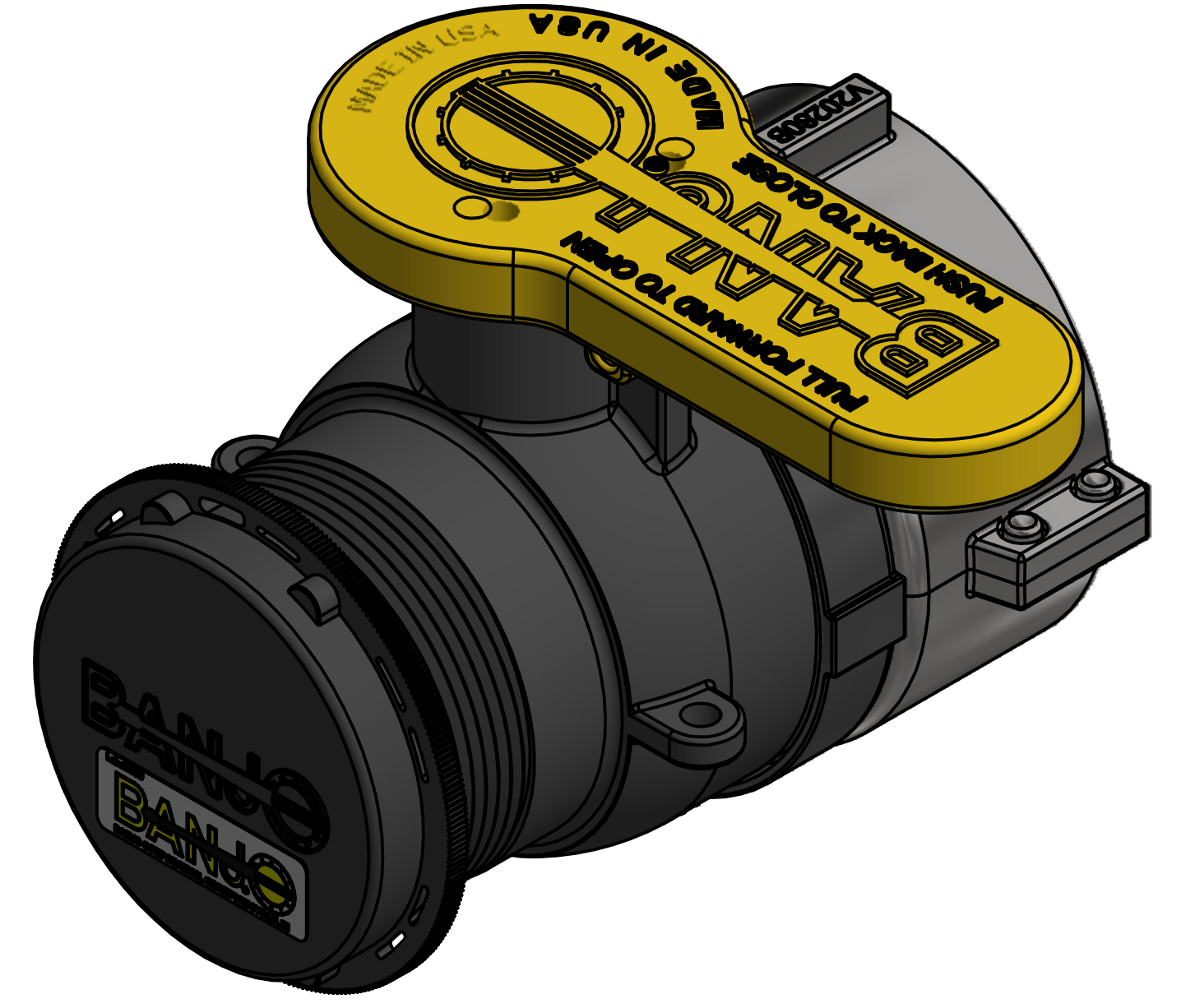

THIS DRAWING AND ALL INFORMATION CONTAINED THEREON ARE THE EXCLUSIVE PROPERTY OF BANJO CORPORATION.  
UNLESS SPECIFICALLY NOTED, THIS DRAWING AND ITEMS SHOWN ON THIS DRAWING ARE SUBJECT TO CHANGE AT ANY TIME.

BANJO CORPORATION  
150 BANJO DRIVE, CRAWFORDSVILLE, IN 47933  
WEB SITE: WWW.BANJO.CORP.COM  
E-MAIL: BANJOSALES@IDEXCORP.COM

DESCRIPTION  
SCHUTZ 2" MPT ALIGNMENT VLV W/SEAL

PART NUMBER  
WSMT210FSA